



深孔加工機械專業製造廠

A Specialized Manufacturer of Deep Hole Drilling Machine

金屬屑壓縮機 CHIP COMPACTOR

適用材質：銅、鐵、鋼、鋁、鑄鐵...等金屬。

Applicable materials: various metal materials, such as bronze, iron, steel, aluminum and cast iron, etc.



MODEL: AMC-1000



碳鋼 Carbon steel



銅 Copper



鋁 Aluminum

解決車、銑、鑽削後之切屑壓縮固塊成型。節省佔地空間，回收切屑油再利用，大幅降低成本。

For compressing chips, generated from turning, milling and drilling operations, into a solid mass. Save space occupation and reclaim cutting fluid for reusing that helps to lower production cost.

鋒鑽機械股份有限公司
ASCENDER MACHINERY INC.

Machine Dimensions

機械尺寸：

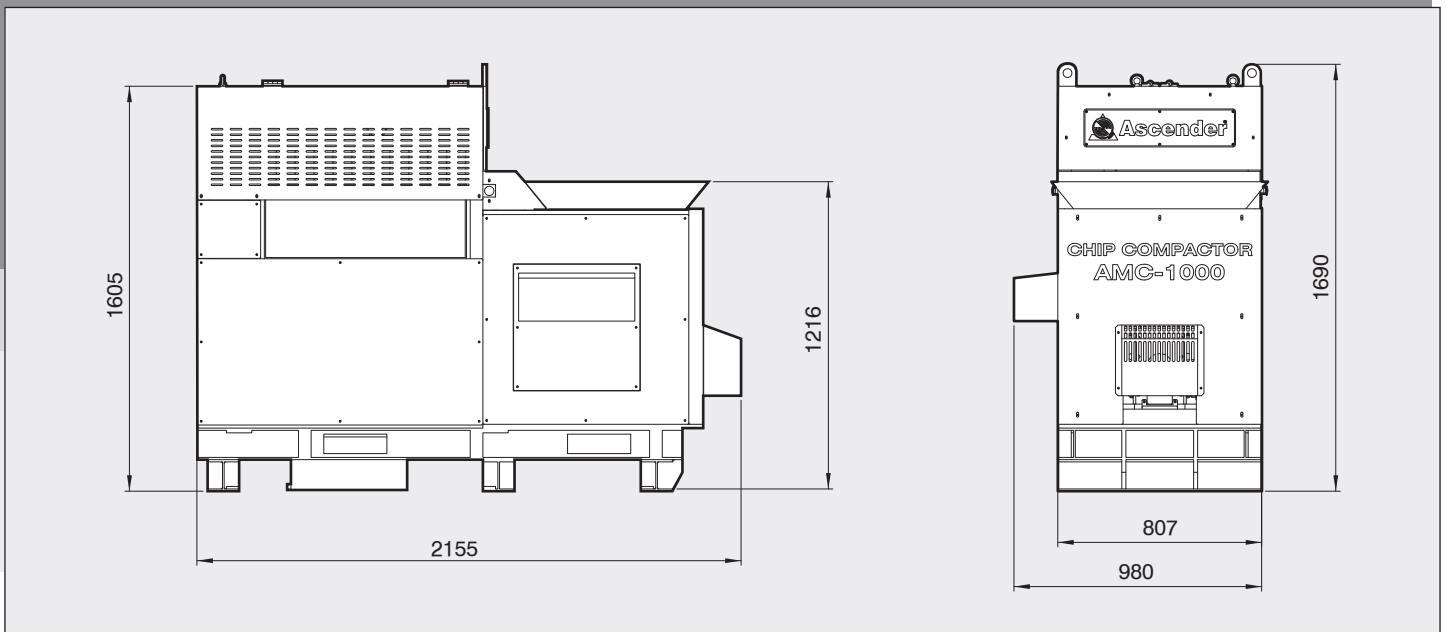

Model		AMC-1000
壓縮能力	Compressing capacity	100 噸 ton
油壓最大壓力	Maximum hydraulic pressure	210 kgs/cm ²
產出壓縮塊直徑	Diameter of compressed block	ø70 mm
壓縮面積	Compressing area	2650 kg/cm ²
油壓箱容量	Hydraulic oil tank capacity	100 L
油壓泵浦馬達	Hydraulic pump motor	7.5 HP
捲屑縱軸馬達	Longitudinal axis motor for chip collection	1 HP
捲屑橫軸馬達	Horizontal axis motor for chip collection	0.5 HP
入料盆容量	Infeed basin capacity	100 L
機械尺寸(長x寬x高)	Machine dimensions (L x W x H)	2155 x 980 x 1690 mm
機械重量	Net weight	1650 kgs

- 本公司對產品規格、設計均不斷研究改進，上述規格若有變更，恕不另行通知。
- Design and specification are subject to change without prior notice.



鋒鑽機械股份有限公司 ASCENDER MACHINERY INC.

台灣42942台中市神岡區國豐路一段163號
ADD: No.163, Sec. 1, Guofeng Rd., Shengang
Dist., Taichung City 42942, Taiwan

TEL: 886-4-2528 3785 FAX: 886-4-2528 3727
E-mail: dhm.ascend@msa.hinet.net
E-mail: info@ascender.com.tw
http://www.ascender.com.tw

經銷商：

