

- 東鉅CNS13638地下防蝕鋼管
- 粉塵管
- 進口無縫鋼管
- 蒸汽凡而
- 彰源被覆不銹鋼管
- 彰源不銹鋼管
- PVC塑膠管
- 進口閘類
- 唯特利溝槽式
- 富山凡而
- 鑫陽鋼管
- 遠東鋼管



Victaulic 唯特利組裝套件

鋒剛實業股份有限公司



鋒剛實業股份有限公司

品質·專業·服務·2019

空調·水電·消防·閘類·配管材料



地址：台中市大雅區信和路1之2號

電話：(04)2568 1118

傳真：(04)2569 2136

http://www.fk.com.tw

E-mail:fk@ws.com.tw

北部公司：富剛管道材料(股)公司

地址：新北市新莊區新樹路52-2號

民國108年3月製2仟



超過 20 年的配管經驗 協助客戶及業主端需求 不斷創造三方皆贏的解決方案

集團內成員皆為營建材料界專業菁英，務實有衝勁，定期辦理內外各項教育訓練，充實專業知識與各項服務訓練，銷售品牌鍍鋅鋼管、不銹鋼管、閥類及機械接頭及各式五金令配件

1. 最佳地理位置—地點位於中清→台中交流道旁，居全省運輸交通樞紐，南來北往運輸快捷。
2. 成熟運輸作業—備超過10輛大小貨車〈含三節式吊桿〉及專業運輸人員，具備機動運輸能力，快速準確配送，全省貼心送達。
3. 完整服務項目—提供完整材料供應鍊需求，銷售買賣、詢價、諮詢並協助各工程公司專人專職送審……等各項及專案客製化服務。
4. 追求中長期目標—積極佈線北、中、南部集合住宅、科園區，建立國內重大公共工程實績，長期深耕佈線，不斷超越自己及同業。
5. 設定企業願景—對外成為配管材料業界之翹楚，對內實踐幸福企業承諾。
6. 秉持企業經營理念—誠信、責任、服務、用心。

近年實績 (2010~2018)

電子廠—旭硝子顯示/群創電子、佳能企業、矽品精密、美光科技后里廠、美光科技林口廠、友達晶材后里廠、南亞科技FAB無塵室、華邦電子、群創電子、高通龍潭廠、日月光中壢廠、大立光LP7、嘉聯益科技、台積12AP5新竹廠、台積F12P6新竹廠、台積F12P7新竹廠、台積15P5台中廠、台積15P7台中廠、台積F14P6台南廠、台積F14P7台南廠、台積18P1台南廠

公共工程—新莊副都心、台中大都會歌劇院、司法院新建辦公廳、台中火力發電廠、福和D、S變電所、通宵電廠、桃園機場捷運線、高雄港阜局、台中BRT、旗美污水廠、龍潭污水廠、桃園BOT污水廠、新竹污水廠第一期、中科三期污水處理廠、中科四期污水處理廠、台中都會區鐵路高架化工程、國家會展中心南港展覽館擴建工程、台北藝術中心興建工程、高雄鐵路地下化(高雄車站)、台鐵C531標、台中捷運北屯線CJ910及G0至G17站、中央研究院國家生技研究園區興建、台北捷運萬大線、台9線蘇花公路隧道A標、台9線蘇花路C標和中大清水段、台9線南迴公路安朔至草埔段、西濱快速公路鳳鼻隧道

商辦、醫院工程—台北陽明大學附設醫院工程/高雄大魯閣草悟道多功能商場開發案、北市林口三井OUTLET PARK、台中三井OUTLET/台北市信義區聯合報大樓、泰豐輪胎觀音廠、中台禪寺國際大博物館、新竹生醫、南港中國信託新建大樓、綠能科技/中國人壽台北學苑、台南奇美醫院、大里仁愛醫院、新竹園區聯發科技

鋒剛實業股份有限公司
FENG GANG CO.,LTD

地址:台中市大雅區三和里信和路1-2號
TEL:(04)25681118 FAX:(04)25692136
統一編號: 97248422
<http://www.fk.com.tw>



鋒剛實業股份有限公司
FENG GANG CO., LTD

代理多家優質產品



1 鍍鋅鋼管、黑鋼管、鍍鋅粉體鋼管、結構用圓鋼管及方型鋼管



2 不銹鋼管及不銹鋼被覆管



3 各式閥類



4 灑水軟管、溝槽式零件及閥類



5 眾鉅不銹鋼雙壓接管件及聚乙烯被覆鋼管

地址:台中市大雅區三和里信和路1-2號
TEL:(04)25681118 FAX:(04)25692136
統一編號: 97248422
<http://www.fk.com.tw>



富山

本體材質	黃 銅			青 (鈷 金) 銅		
品 名	閘門閥	橫式逆止閥	鍛造球塞閥	閘門閥	閘門閥	閘門閥
圖 型	 ㊟字驗證	 ㊟字驗證	 UL 驗證 FM 驗證 全流量	 ㊟字驗證	 昇桿型	
標稱壓力	125PSI			125PSI	300 WOG	300 WOG
編號	FS-101	FS-201	FS-301	FS-103	FS-104	FS-109
口徑						
1/4" 3/8"	340		500	480		
1/2"	340	390	530	480	1160	700
3/4"	480	520	730	640	1640	910
1"	670	730	1030	870	2400	1390
1-1/4"	980	1030	1400	1270	3660	1810
1-1/2"	1200	1290	1900	1520	4470	2440
2"	1810	1870	3000	2250	7250	3890
2-1/2"	3540	3870	7000	4340	9940	5840
3"	5180	5220	9600	6330	13870	7500
4"	9050	8240	13000	10650		





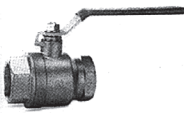
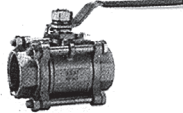
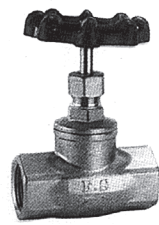

本體材質	青 (鈷 金) 銅			青 (鈷 金) 銅		
品 名	橫式逆止閥	無聲逆止閥	球塞閥	球型閥	球型墊片閥	閘門閥
圖 型	 ㊟字驗證		 全流量 ㊟字驗證			 法蘭式
標稱壓力	125PSI	125PSI	600 WOG	125PSI	150PSI	10K
編號	FS-203	FS-204	FS-303	FS-403	FS-404	FS-020
口徑						
3/8"			550			
1/2"	480	560	590	540	940	
3/4"	630	720	810	700	1410	
1"	880	920	1140	1050	2130	
1-1/4"	1170	1160	1550	1770	3070	
1-1/2"	1560	1620	2000	2380	4490	
2"	2240	2340	3120	3920	7340	17500
2-1/2"	4580	5770	7260		12430	26600
3"	6440	7230	10040		17570	34000
4"	9990					46200

富山

本體材質	青 (鈾金) 銅			不 銹 鋼		
品 名	減壓閥	自動釋氣閥	水錘吸收器	Y 型過濾器	閘門閥	橫式逆止閥
圖 型	附103 X 3只 803 X 1只 		2 1/2" 以上內牙 			
標稱壓力	300PSI			150PSI	300PSI	
編號	FS-501	FS-601	FS-701	FS-803	FS-111	FS-211
口徑						
1/2"	2280	1200	1400	720	2850	2790
3/4"	2500	1300	1650	1080	3430	3240
1"	4400	1400	3300	1550	4380	3950
1-1/4"	6600		4800	2500	5720	5460
1-1/2"	7400		6900	3200	7790	6880
2"	8400		9100	5130	10270	8550
2-1/2"			20000	7600	29000	
3"			41500	11270		

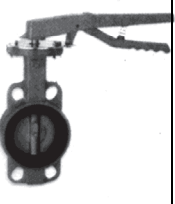

本體材質	不 銹 鋼				不 銹 鋼	
品 名	球 塞 閥	球 塞 閥	球 塞 閥	球 塞 閥	球 型 閥	Y 型 過 濾 器
圖 型	單片式 	雙片式 	三片式 	套焊式 (S) 對焊式 (B) 		
標稱壓力	1000PSI				300PSI	300PSI
編號	FS-311	FS-312	FS-313	FS-313S FS-313B	FS-411	FS-811
口徑						
1/4" 3/8"	730	1270	1600	1820		
1/2"	940	1350	2130	2440	2870	2070
3/4"	1170	2020	2640	3000	3480	2500
1"	1530	2480	3370	3870	4510	3430
1-1/4"	2220	3670	4510	5200	5950	3750
1-1/2"	2720	5040	6250	7020	8390	5190
2"	3870	7420	9510	11100	10470	11600
2-1/2"		17020	電話報價			
3"		23780	電話報價			
4"						



富山

本體材質		灰口鑄鐵					
品名	蝶型閥	蝶型閥	蝶型閥	蝶型閥	閘門閥	閘門閥	
圖型		齒輪式 	葉片不銹鋼 	葉片不銹鋼 	㊦字驗證 	昇桿型 ㊦字驗證 	
標稱壓力	10K						
編號	FS-041	FS-042	FS-043	FS-044	FS-051	FS-052	
口徑							
2"	3720	7870	4430	8490	7030	8400	
2-1/2"	3950	8000	4580	8820	8020	9660	
3"	4270	8450	5460	9830	10570	12380	
4"	5060	9190	6650	11030	14100	16770	
5"	6260	10380	8440	12700	20350	22350	
6"	7460	11360	10550	14950	27040	28760	
8"	10600	17240	15100	24100	41660	45100	
10"	15400	23490	24500	34400	71300	74300	
12"	20000	28090	32700	48530	103740	104680	
14"		65000		82000			
16"		82000		100000			

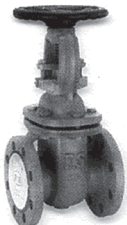
本體材質		灰口鑄鐵					
品名	橫式逆止閥	橫式逆止閥	無聲逆止閥	雙瓣式逆止閥	拉柄式底閥	Y型過濾器	
圖型		㊦字驗證 					
標稱壓力	10K						
編號	FS-071	FS-072	FS-073	FS-074	FS-075	FS-081	
口徑							
2"	3240	12000	5900	3980	8050	3750	
2-1/2"	4230	14500	8440	4150	9600	5240	
3"	4670	18000	10600	5230	11360	6360	
4"	7870	22000	12970	6540	14640	9850	
5"	10740	30000	19780	8400	19100	14460	
6"	15350	40000	26490	11140	26100	20640	
8"	26790	62000	38960	19050	48030	34220	
10"	37070	88000	63680	32490	80000	57370	
12"		115000	94000	47330	105000	80720	
14"			480000	65000		180000	
16"			750000	94000		270000	

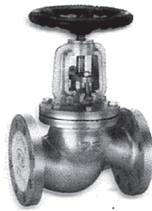

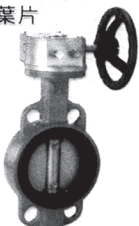
富山



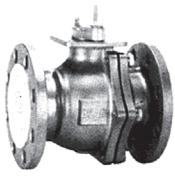
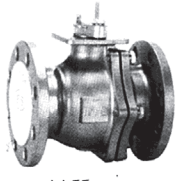
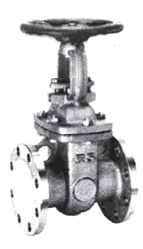
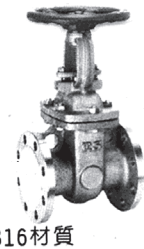
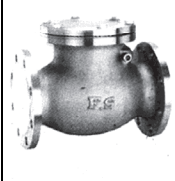

本體材質		球狀石墨鑄鐵					
品名	灰口鑄鐵	球型閥	昇桿閘門閥	橫式逆止閥	Y型過濾器	球型閥	蝶型閥
圖型							不銹鋼葉片
標稱壓力	10K	16K					
編號	FS-091	FS-011	FS-012	FS-013	FS-014	FS-015	
口徑							
2"	7550	15080	14830	6590	18000	5340	
2-1/2"	9520	18680	17170	9840	22800	6000	
3"	11170	23900	21350	12190	26700	6890	
4"	14930	30690	25180	17090	42000	8340	
5"	22930	44080	34200	25590	63470	11120	
6"	29700	56370	43350	35970	77500	14450	
8"	48190	85560	70020	52980	127000	21000	
10"	105090	115560	100070	80370	225000		
12"		214100	146440	113600	380000		
14"				180000			
16"				270000			

本體材質		球狀石墨鑄鐵			
品名	齒輪式蝶閥	無聲逆止閥	雙瓣式逆止閥	拉柄式底閥	
圖型					
標稱壓力	16K				
編號	FS-016	FS-017	FS-018	FS-019	
口徑					
2"	10560	12230	6890	12000	
2-1/2"	11670	15560	7780	14000	
3"	13340	19560	8670	17000	
4"	14450	26000	11670	22000	
5"	17780	34230	15560	29000	
6"	21670	45830	21120	39000	
8"	31670	86890	35600	72000	
10"	42230	140670	45560		
12"	56670	250230	70000		
14"	96000	480000			
16"	245000	750000			

富山

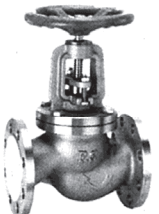

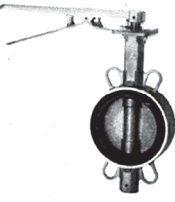
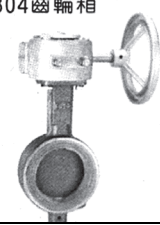
不 銹 鋼

本體材質		不 銹 鋼					
品 名	球塞閥	球塞閥	閘門閥	閘門閥	橫式逆止閥	Y型過濾器	
圖 型		 316材質		 316材質			
標稱壓力	10K						
編號	FS-030	FS-030M (316)	FS-031	FS-031M (316)	FS-032	FS-033	
口徑							
2"	15790	實價	24490	實價	22120	24000	
2-1/2"	19870	實價	31600	實價	31730	31720	
3"	27320	實價	42890	實價	34700	39680	
4"	33380	實價	54440	實價	49990	50050	
5"	87930	實價	70800	實價	70660	89130	
6"	112970	實價	98260	實價	93830	98990	
8"	齒 輪 式	224000	實價	242000	實價	182000	176000
10"		363600	實價	338000	實價	338000	348000
12"		601800	實價	508000	實價	538000	564000
14"			實價	實價		實價	
16"			實價	實價		實價	



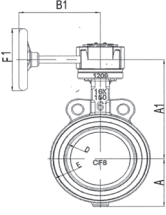

本體材質		不 銹 鋼				
品 名	球型閥	拉柄式底閥	蝶型閥	齒輪式蝶閥	雙瓣式逆止閥	無聲逆止閥
圖 型				 304齒輪箱		 附回水裝置
標稱壓力	10K					
編號	FS-034	FS-035	FS-037	FS-038	FS-039	FS-040
口徑						
2"	21120	25560	8820	16670	9490	41120
2-1/2"	30000	27780	10040	18060	9990	46670
3"	35000	35000	11940	20370	11190	57780
4"	50000	42230	15000	23840	15950	76670
5"	77780	54450	21960	33000	19950	97780
6"	111120	66670	26290	37500	27480	127780
8"	211120	109200	45000	58340	42600	188890
10"	300000	電話報價	65500	85560	70800	238890
12"	電話報價	電話報價	95000	112000	104490	311120
14"				188000	電話報價	電話報價
16"				247000	電話報價	電話報價



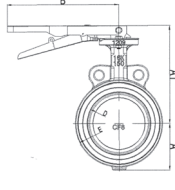
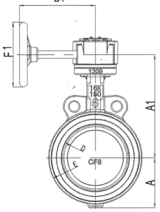
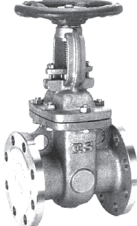

富山

本體材質		不 銹 鋼				
品 名	無聲逆止閥	減壓閥	釋氣閥 (大流量)	水錘吸收器 (PT 牙)	水錘吸收器 (法蘭式)	球塞閥 (法蘭式)
圖 型						
標稱壓力	10K					10K
編號	FS-214	FS-511	FS-612	FS-711	FS-712	FS-030
口徑						
1/2"	3250	10000	17000	3700		5430
3/4"	3750	12500	17000	4900		5800
1"	4400	15800	18000	7400		7620
1 1/4"	6400	18800		14800		9950
1 1/2"	8000	23000		19000		11730
2"	11500	27500		26400		
2 1/2"	22000				52000	
3"	27000				92000	
4"					125000	



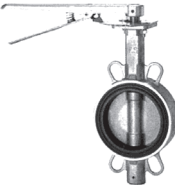

本體材質		球 墨 鑄 鐵				黃 銅
品 名	彈性座封閘閥	彈性座封逆止閥	偏心柱塞閥	偏心蝶閥 (把手式 304 葉片)	偏心蝶閥 (齒輪式 304 葉片)	水錘吸收器 (法蘭式)
圖 型						
標稱壓力	10K	10K	10K	10K/16K	10K/16K	10K
編號	FS-011F	FS-012F	FS-014F	FS-021D	FS-022D	FS-702
口徑						
2"	14000	14000	24000			
2 1/2"				11500	19000	25000
3"	20000	20000	34000	13500	21000	43800
4"	28000	28000	40000	16000	24000	65000
5"				20000	28000	
6"	42000	42000	72000	28000	37000	
8"	60000	60000	84000	40000	50000	
10"					90000	
12"					110000	

富山

本體材質		不 銹 鋼				
品 名	偏心蝶閥 (把手式)	偏心蝶閥 (齒輪式)	昇桿式閘閥	橫式逆止閥	Y型過濾器	拉柄式底閥
圖 型						
標稱壓力	10K/16K	10K/16K	16K	16K	16K	16K
編號	FS-021	FS-022	FS-031K	FS-032K	FS-033K	FS-035K
口徑						
2"			38500	36900	40000	
2-1/2"	21000	26000	49600	52900	52800	
3"	25000	30000	67500	57800	66200	電話報價
4"	30000	35000	85600	83300	83500	78000
5"	40000	45000	111400	117800	148600	電話報價
6"	50000	60000	154500	156400	166000	125000
8"	72000	85000	340000	272000	280000	電話報價
10"		150000	電話報價	電話報價	電話報價	電話報價
12"		190000	電話報價	電話報價	電話報價	

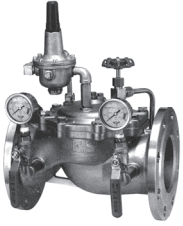
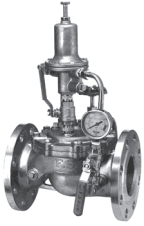
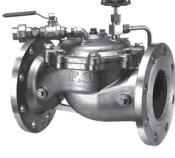
本體材質		不 銹 鋼				砲金銅	鑄鐵
品 名	蝶型閥	蝶型閥(齒輪式)	雙瓣式逆止閥	無聲逆止閥	橫式逆止閥	大流量釋氣閥	
圖 型							
標稱壓力	16K	16K	16K	16K	300PSI		10K
編號	FS-037K	FS-038K	FS-039K	FS-040K	FS-209		FS-602
口徑							
2"	13860	26200	18000	70500	1/2"	910	8000
2-1/2"	15800	28400	19000	80500	3/4"	1190	8000
3"	18760	33000	21400	99500	1"	1740	8500
4"	23580	37500	30400	131600	1 1/4"	2440	
5"	34520	52000	38000	167700	1 1/2"	3060	
6"	41330	59000	52500	219500	2"	4870	
8"	72000	91700	81200	324000			
10"		134500	135000	410000			
12"		178000	200000	534000			

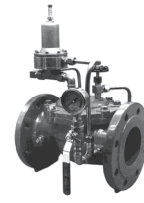
富山

本體材質		不 銹 鋼			鑄 鐵		
品 名	不銹鋼 減壓閥	不銹鋼 持壓/洩壓閥	不銹鋼 定水位閥	鑄鐵 減壓閥	鑄鐵 持壓/洩壓閥	鑄鐵 定水位閥	
圖 型							
標稱壓力	10K	10K	10K	10K	10K	10K	
編號	FS-065S	FS-066S	FS-067S	FS-065F	FS-066F	FS-067F	
口徑	2"	30500	30500	25800	9400	10050	7700
	2 1/2"	37100	37100	32400	13500	14400	11800
	3"	48300	48300	43600	15600	16800	14200
	4"	64600	64600	59900	20800	22400	19500
	5"	105900	105900	100400	35700	38300	33600
	6"	114800	114800	110000	40800	44200	39200
	8"	247500	247500	243000	98400	106600	97200
	10" 以上	電話報價	電話報價	電話報價	電話報價	電話報價	電話報價

本體材質		球 墨 鑄 鐵				不 銹 鋼	
品 名	減壓閥	持壓 / 減壓閥	定水位閥	壓力調整閥	316 持壓 / 洩壓閥	316 減壓閥	
圖 型							
標稱壓力	16K	16K	16K	16K	PT 內牙	PT 內牙	
編號	FS-065FK	FS-066FK	FS-067FK	FS-068K		FS-566	
口徑	2"	11500	11500	9900	17700	1/2"	6600
	2-1/2"	16400	16400	14700	22600	3/4"	7700
	3"	19800	19800	18400	25400	1"	8250
	4"	25200	25200	23700	30500	1 1/2"	14300
	5"	44800	44800	43000	49800	2"	16500
	6"	52800	52800	51400	54300		
	8"	127200	127200	126000	118400		
	10" 以上	電話報價	電話報價	電話報價	電話報價		

Victaulic 消防/空調系統溝槽式閥類

型號 品名	761(VIC-300)	761(VIC-300)	716	705	717
	把手式蝶閥	齒輪式蝶閥	止回閥	消防UL/FM蝶閥	消防UL/FM止回閥
尺寸(外徑 mm)					
2"	14423	實售價	-	-	-
2 1/2"(73)	15734	實售價	14685	22948	18102
2 1/2"(76)	15734	實售價	14685	22948	18102
3"	17045	實售價	16259	24222	19888
4"	18881	實售價	23601	25497	22946
5"(139)	-	實售價	25262	30595	38912
5"(141)	28847	實售價	37239	30595	37434
6"(165)	31469	實售價	41959	38243	46148
6"(168)	31469	實售價	41959	38243	46148
8"	-	57694	73427	73939	77253
10"	-	82607	118009	161133	140583
12"	-	90475	157345	229974	164150

型號 品名	S461	S461	S416	731	732
	把手式蝶閥	齒輪式蝶閥	止回閥	整流過濾器	Y型過濾器
尺寸(外徑)					
2"	實售價	實售價	實售價	-	23601
2 1/2"(73)	實售價	實售價	實售價	-	26225
2 1/2"(76)	實售價	實售價	實售價	-	26225
3"	實售價	實售價	實售價	33120	27536
4"	實售價	實售價	實售價	36444	30158
5"(139)	實售價	實售價	實售價	-	36469
5"(141)	實售價	實售價	實售價	56940	52448
6"(165)	實售價	實售價	實售價	-	57694
6"(168)	實售價	實售價	實售價	65647	57694
8"	實售價	實售價	實售價	105252	83918
10"	實售價	實售價	實售價	153207	209795
12"	實售價	實售價	實售價	269526	277978

Vic-300 MasterSeal 蝶閥

761 系列

設計用於全額工作壓力下的雙向、盲端應用場合

可供不帶手柄、帶齒輪操作、帶手柄或帶 10 位置手柄和記憶定位

尺寸 DN50-DN300 | 2-12 英寸

壓力可達 300psi | 2068kPa | 21bar



Vic-Check 逆止閥

716H 系列

特有不銹鋼閥板

尺寸 DN50-DN80 | 2-3 英寸

壓力可達 365psi | 2517kPa | 25bar



Vic-Strainer Y 型過濾器

732 系列

在較低壓力落差時,提供直通流道

尺寸 DN50-DN300 | 2-12 英寸

壓力可達 300psi | 2068kPa | 21bar



FireLock 蝶閥-開啟位置監控

705 系列

耐候執行機構外殼取得認證,適用於室內及室外應用場合

球墨鑄鐵閥體與帶丁晴底座的閥板

尺寸 2-12 英寸 | 50-300 毫米

壓力可達 300psi | 2068kPa | 21 巴

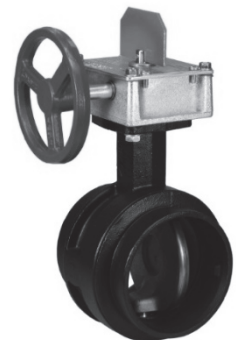

FireLock 止回閥

717 系列

特有橡膠封裝閥板和無電鍍鎳閥座

尺寸 2½-12 英寸 | 65-300 毫米

壓力可達 365psi | 2517kPa | 25 巴



Vic-300 MasterSeal 不銹鋼蝶閥

461 系列

設計用於全額工作壓力下的雙向、盲端應用場合

可供不帶手柄、帶齒輪操作、帶手柄或帶 10 位置

手柄和記憶定位

尺寸 DN50-DN200 | 2-8 英寸

壓力可達 300psi | 2068kPa | 21bar



Vic 不銹鋼逆止閥

416 系列

彈簧座彈簧迴轉止回閥設計用於水平或垂直（向上流動）應用

尺寸 2 – 12 英寸 | DN50-DN200

壓力可達 300 psi | 2068 kPa | 21 巴



FireLock 止回閥

717 系列

特有橡膠封裝閥板和無電鍍鎳閥座

尺寸 2½-12 英寸 | 65-300 毫米

壓力可達 365psi | 2517kPa | 25 巴



Vic-300 MasterSeal 不銹鋼蝶閥

461 系列

設計用於全額工作壓力下的雙向、盲端應用場合

可供不帶手柄、帶齒輪操作、帶手柄或帶 10 位置

手柄和記憶定位

尺寸 DN50-DN200 | 2-8 英寸

壓力可達 300psi | 2068kPa | 21bar



Vic 不銹鋼逆止閥

416 系列

彈簧座彈簧迴轉止回閥設計用於水平或垂直（向上流動）應用

尺寸 2 – 12 英寸 | DN50-DN200

壓力可達 300 psi | 2068 kPa | 21 巴





子母式-減壓閥〔活塞型〕**消防,給水**

材質	壓力等級	型號	1 1/2"牙口	2" 牙口	2"法蘭	2 1/2"法蘭	3"法蘭	4"法蘭	5"法蘭	6"法蘭	8"法蘭	10"以上
鑄鐵	10K	BTR / BFR型	****	8,200	8,700	9,600	12,000	16,000	25,500	34,000	82,000	實售價
石墨鑄鐵	16K	BFR型	****	****	10,500	12,600	16,500	21,000	32,000	44,000	106,000	實售價
砲金銅	10K	BTR / BFR型	7,500	17,700	21,500	26,400	33,500	45,500		90,000		實售價
SS-304	10K	BTR / BFR型	16,300	****	27,700	33,700	43,900	58,700	81,400	104,300	225,000	實售價



消防壓力調整閥〔消防幫浦入口調壓閥〕

中繼專用-壓力錶2分牙口 附三通、排氣考克

材質	壓力等級	型號	2"法蘭	2.5"法蘭	3"法蘭	4"法蘭	5"法蘭	6"法蘭	8"法蘭
鑄鐵	10K	FFR型	15,600	18,500	21,300	25,500	35,000	44,300	93,700
石墨鑄鐵	16K	FFR型	17,700	22,600	25,400	30,500	41,500	54,300	118,400
SS-304	10K	FFR型	36,600	42,600	52,800	68,200	90,900	114,600	236,800



直動式減壓閥〔隔膜型〕**家庭公共給水**

★隔膜型減壓 壓力錶需另購

材質	規格	型號	1/2"	3/4"	1"	1 1/4"	1 1/2"	2"	2 1/2"	3"	4"	6"
SS-304	PT 內牙	RDT型	3,650	4,500	4,950	6,000	9,350	10,000	****	****	****	****
砲金銅	PT 內牙	RDT型	實售價	實售價	實售價	實售價	實售價	實售價	實售價	****	****	****
砲金銅	10K	RDF型	****	****	****	****	****	實售價	實售價	實售價	實售價	****
鑄鐵	10K	RDF型	****	****	****	****	****	7,800	11,200	14,500	20,000	****



直動式減壓閥 複合型含錶*工業製程(低壓、微壓另外報價)

材質	規格	型號	1/2"	3/4"	1"	1 1/4"	1 1/2"	2"	2 1/2"	3"	4"	6"
SS-316	PT 內牙	RET型	6,000	7,000	7,500	****	13,000	15,000	****	****	****	****
SS-316	10K	REF型	9,400	10,400	11,400	18,500	18,500	20,700	37,900	51,900	69,700	117,200



減壓閥組〔模組型〕**家庭公共給水**

材質	規格	型號	3/4"	1"
砲金銅	PT 內牙	RS型	3,700	4,300

定水位閥〔隔膜型〕**牌價不含浮球開關



材質	壓力等級	型號	1 1/2"牙口	2"牙口	2"法蘭	2 1/2"法蘭	3"法蘭	4"法蘭	6"法蘭	8"法蘭
鑄鐵	10K	DFE / DTF型	5,800	6,200	6,500	8,400	10,300	14,300	29,700	77,200
砲金銅	10K	DFE / DTF型	7,450	11,200	20,000	24,900	30,600	44,000	88,600	
SS-304	10K	DFE / DTF型	10,600	15,750	21,500	27,750	32,900	48,600	94,300	211,500

定水位閥〔活塞型〕**牌價不含浮球開關



材質	壓力等級	型號	1 1/2"牙口	2"牙口	2"法蘭	2 1/2"法蘭	3"法蘭	4"法蘭	5"法蘭	6"法蘭	8"法蘭	10"以上
鑄鐵	10K	BFE / BTF型	****	7,000	7,500	8,400	10,900	15,000	24,000	32,600	81,000	實售價
石墨鑄鐵	16K	BFE型	****	****	9,300	11,300	15,300	19,700	30,700	42,800	105,500	實售價
砲金銅	10K	BFE / BTF型	6,000	16,200	20,000	24,900	32,000	44,000		88,600		
SS-304	10K	BFE / BTF型	12,000	****	23,450	29,400	39,600	54,400	77,200	100,000	220,800	實售價

液位控制閥〔隔膜型〕**適用無壓力場合**



材質	壓力等級	型號	2 1/2"法蘭	3"法蘭	4"法蘭	6"法蘭
鑄鐵	10K	DFM 型	實售價	實售價	實售價	實售價
SS-304	10K	DFM 型	實售價	實售價	實售價	實售價

電磁閥 - (常閉. 室內用)〔活塞型〕**含手動開關**



材質	壓力等級	型號	1 1/2"牙口	2"牙口	2"法蘭	2 1/2"法蘭	3"法蘭	4"法蘭	5"法蘭	6"法蘭	8"法蘭
鑄鐵	10K	BTE / BFE型	****	14,000	14,500	15,400	18,000	22,000	31,500	39,600	88,000
石墨鑄鐵	16K	BFE型	****	****	16,100	18,500	22,300	26,400	37,700	49,800	112,500
砲金銅	10K	BTE / BFE型	14,200	24,500	27,200	32,000	39,200	51,200		95,700	
SS-304	10K	BTE / BFE型	24,900	****	36,300	42,300	52,500	67,300	90,000	112,900	233,700

靜音逆止閥〔全開型〕



材質	壓力等級	型號	2"	2 1/2"	3"	4"	5"	6"	8"	10"	12"
鑄鐵	10K	CHF型	3,450	4,300	5,300	7,200	9,200	12,300	24,300	實售價	實售價
石墨鑄鐵	16K	CHF型	6,750	8,700	10,900	14,500	19,200	25,600	48,600	實售價	實售價
SS-304	10K	CHF型	18,000	22,900	27,500	36,600	46,600	59,000	110,000	實售價	實售價

子母式-持壓閥〔活塞型〕**自來水錶處、工業幹管持壓**



材質	壓力等級	型號	1 1/2"牙口	2" 牙口	2"法蘭	2 1/2"法蘭	3"法蘭	4"法蘭	5"法蘭	6"法蘭	8"法蘭	10"以上
鑄鐵	10K	BTS / BFS型	****	8,200	8,700	9,600	12,000	16,000	25,500	34,000	82,000	實售價
石墨鑄鐵	16K	BTS / BFS型	****	****	10,500	12,600	16,500	21,000	32,000	44,000	106,000	實售價
砲金銅	10K	BTS / BFS型	7,500	17,700	21,500	26,400	33,500	45,500		90,000		
SS-304	10K	BTS / BFS型	16,300	****	27,700	33,700	43,900	58,700	81,400	104,300	225,000	實售價

子母式-洩壓閥〔活塞型〕**大流量排放安全系統**



材質	壓力等級	型號	1 1/2"牙口	2" 牙口	2"法蘭	2 1/2"法蘭	3"法蘭	4"法蘭	5"法蘭	6"法蘭	8"法蘭	10"以上
鑄鐵	10K	BTL / BFL型	****	8,200	8,700	9,600	12,000	16,000	25,500	34,000	82,000	實售價
石墨鑄鐵	16K	BTL / BFL型	****	****	10,500	12,600	16,500	21,000	32,000	44,000	106,000	實售價
砲金銅	10K	BTL / BFL型	7,500	17,700	21,500	26,400	33,500	45,500		90,000		
SS-304	10K	BTL / BFL型	16,300	****	27,700	33,700	43,900	58,700	81,400	104,300	225,000	實售價

直動式-洩壓閥〔複合型〕**(揚水管防水錘)安全等系統** ★消防高壓需另外報價



材質	規格	型號	1/2"	3/4"	1"	1 1/4"	1 1/2"	2"	2 1/2"	3"	4"	6"
SS-316	PT 內牙	RLT型	6,000	7,000	7,500	****	13,000	15,000	****	****	****	****
SS-316	10K	RLF型	9,400	10,400	11,400	18,500	18,500	20,700	37,900	51,900	69,700	117,200

直動式-背壓閥〔複合型〕**工業製程管內持壓等系統**



材質	規格	型號	1/2"	3/4"	1"	1 1/4"	1 1/2"	2"	2 1/2"	3"	4"	6"
SS-316	PT 內牙	RFT型	6,000	7,000	7,500	****	13,000	15,000	****	****	****	****
SS-316	10K	RFF型	9,400	10,400	11,400	18,500	18,500	20,700	37,900	51,900	69,700	117,200



水錘防止器〔直型-外牙〕

材質	規格	型號	1/2"	3/4"	1"	1 1/4"	1 1/2"	2"	2 1/2"	3"	4"
砲金銅	PT 外牙	AIT型				1,600	2,300	4,300	5,800	10,900	22,300
SS-304	PT 外牙	AIT型				3,000	4,000	7,750	11,700	18,600	*****
SS-304	PT 外牙	APT型	實售價	實售價	實售價						



水錘防止器〔直型-法蘭〕

材質	壓力等級	型號	3"	4"	5"	6"	8"	10"	12"
鑄鐵	10K	AIF型	7,700	15,000	16,500	28,500	46,700	實售價	實售價
石墨鑄鐵	16K	AIF型	9,250	18,000	19,800	34,200	56,000	實售價	實售價
砲金銅	10K	AIF型	22,300	30,000	41,500				
SS-304	10K	AIF型	29,000	38,600	47,000	95,000	160,000	實售價	實售價



水錘防止器〔彎頭型-法蘭〕

材質	壓力等級	型號	2"	2 1/2"	3"	4"	6"
鑄鐵	10K	ALF型	6,000	7,450	10,000	16,600	31,400
SS-304	10K	ALF型	27,700	34,300	44,300	62,900	135,800



水錘防止器〔角閥型-外牙〕

材質	規格	型號	1/2"	3/4"
黃銅	PT 外牙	AXT型	實售價	實售價



大流量-直動減壓閥(帶過濾器)

材質	規格	型號	3/4"	1"	1 1/2"	2"
砲金銅	PT 內牙	RDST型	實售價	實售價	實售價	實售價
SS-304	PT 內牙	RDST型	實售價	實售價	實售價	實售價

實價產品：底閥(FVF)、排氣閥(ATR、ATRF)、大氣囊水錘防止器(APT)、角閥型水錘防止器(AXT)
 大流量隔膜減壓(RDST)、消防直動洩壓閥(FRLF)、
 減壓閥組全系列、調壓太平龍頭(HRT)、液位控制閥(DFM)



調壓太平龍頭

砲金銅-內牙式	1-1/2"	2-1/2"
型號：HRT型	實售價	實售價



大流量直動減壓閥

型號-RDST型	3/4"	1"	1-1/2"	2"
砲金銅-內牙式	實售價	實售價	實售價	實售價
不鏽鋼-內牙式	實售價	實售價	實售價	實售價



傳統式減壓閥組 (球塞關斷)

不銹鋼-內牙式	3/4" 1" 1 1/2" 2"
型號：RS-901型	實售價



傳統式減壓閥組 (球塞/蝶閥/閘閥)

法蘭式	2" ~ 6"
鑄鐵 / 不鏽鋼	實售價
型號：RS-201F型	



單組式減壓閥組 (球型關斷)

砲金銅-內牙式	3/4"	1"
型號：RS-100型	實售價	實售價



單組式減壓閥組 (球塞關斷)

砲金銅-內牙式	3/4"	1"
型號：RS-131H型	實售價	實售價



傳統式減壓閥組 (球塞關斷)

砲金銅-內牙式	3/4"	1"	1-1/2"	2"
型號：RS-201H型	實售價	實售價	實售價	實售價



單組式減壓閥組 (球塞關斷)

砲金銅-內牙式	3/4"	1"	1-1/2"	2"
型號：RS-101H型	實售價	實售價	實售價	實售價



傳統式減壓閥組 (球塞關斷)

砲金銅-內牙式	3/4"	1"
型號：RS-231H型	實售價	實售價

給水配管參考示意圖

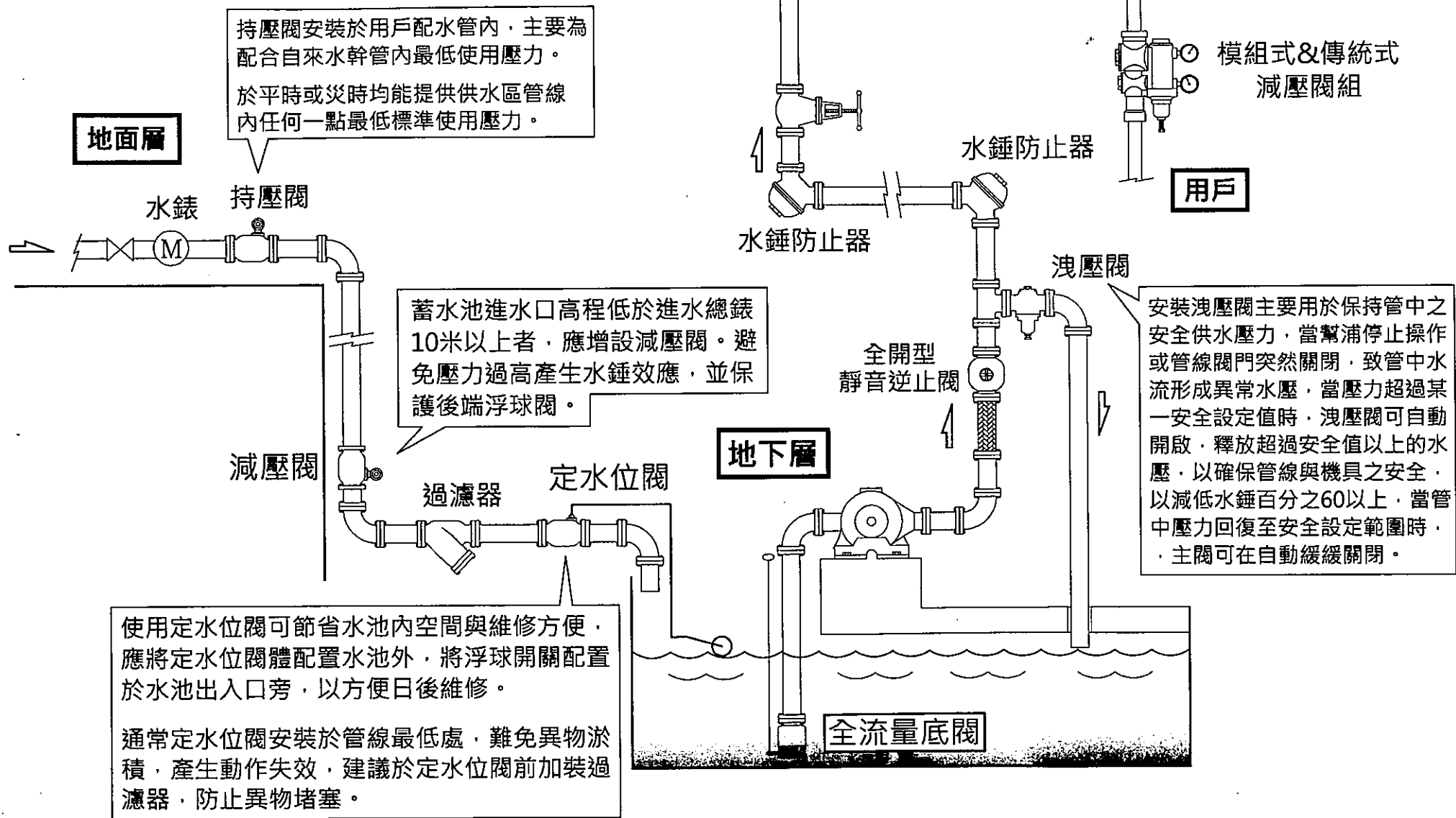

持壓閥安裝於用戶配水管內，主要為配合自來水幹管內最低使用壓力。於平時或災時均能提供供水區管線內任何一點最低標準使用壓力。

地面層

水錶

持壓閥

減壓閥

蓄水池進水口高程低於進水總錶10米以上者，應增設減壓閥。避免壓力過高產生水錘效應，並保護後端浮球閥。

過濾器

定水位閥

使用定水位閥可節省水池內空間與維修方便，應將定水位閥體配置水池外，將浮球開關配置於水池出入口旁，以方便日後維修。

通常定水位閥安裝於管線最低處，難免異物淤積，產生動作失效，建議於定水位閥前加裝過濾器，防止異物堵塞。

地下層

全開型
靜音逆止閥

水錘防止器

水錘防止器

洩壓閥

安裝洩壓閥主要用於保持管中之安全供水壓力，當幫浦停止操作或管線閥門突然關閉，致管中水流形成異常水壓，當壓力超過某一安全設定值時，洩壓閥可自動開啟，釋放超過安全值以上的水壓，以確保管線與機具之安全，以減低水錘百分之60以上，當管中壓力回復至安全設定範圍時，主閥可在自動緩緩關閉。

模組式&傳統式
減壓閥組

用戶

全流量底閥

連結配管參考圖

閥類

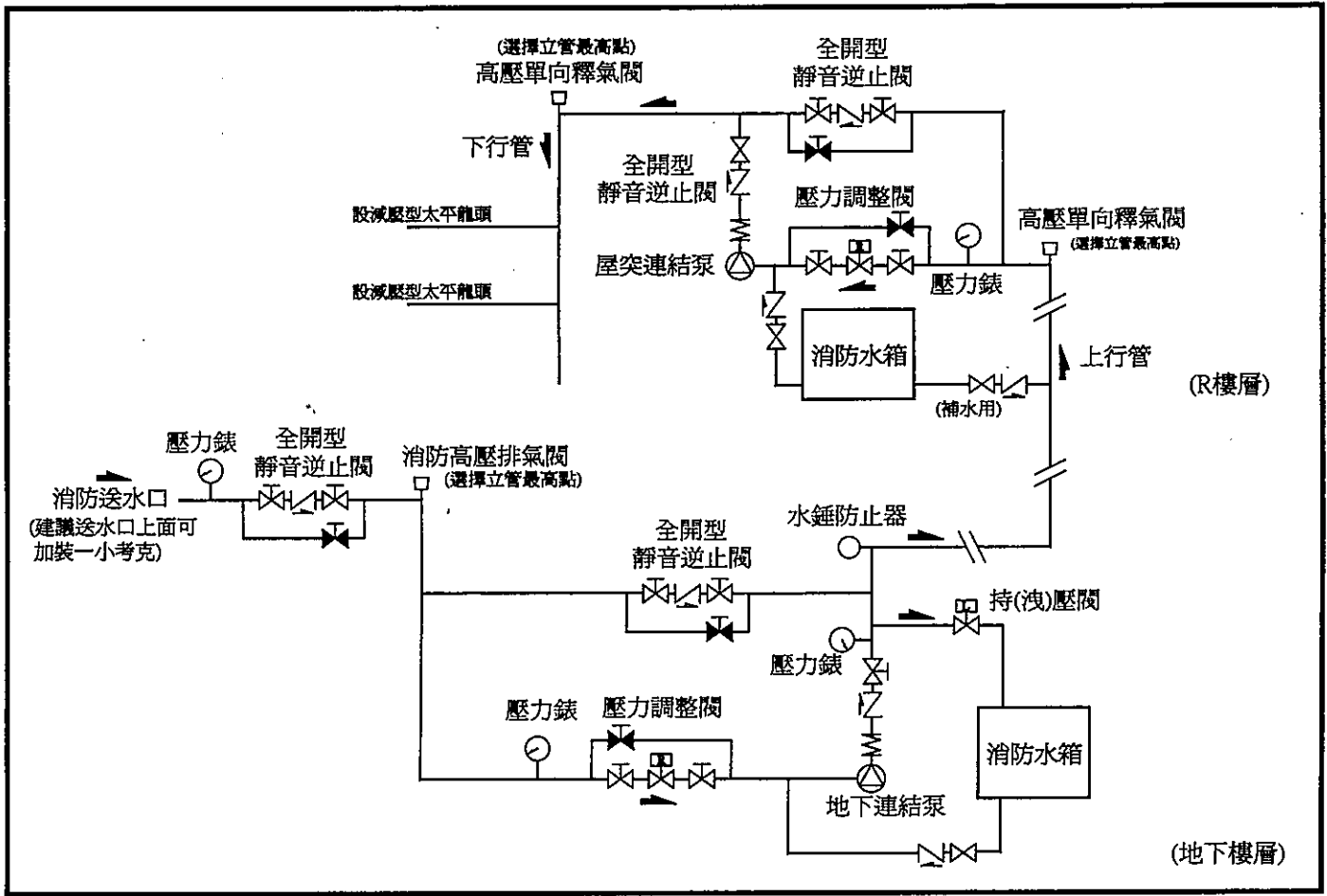

灑水配管參考圖

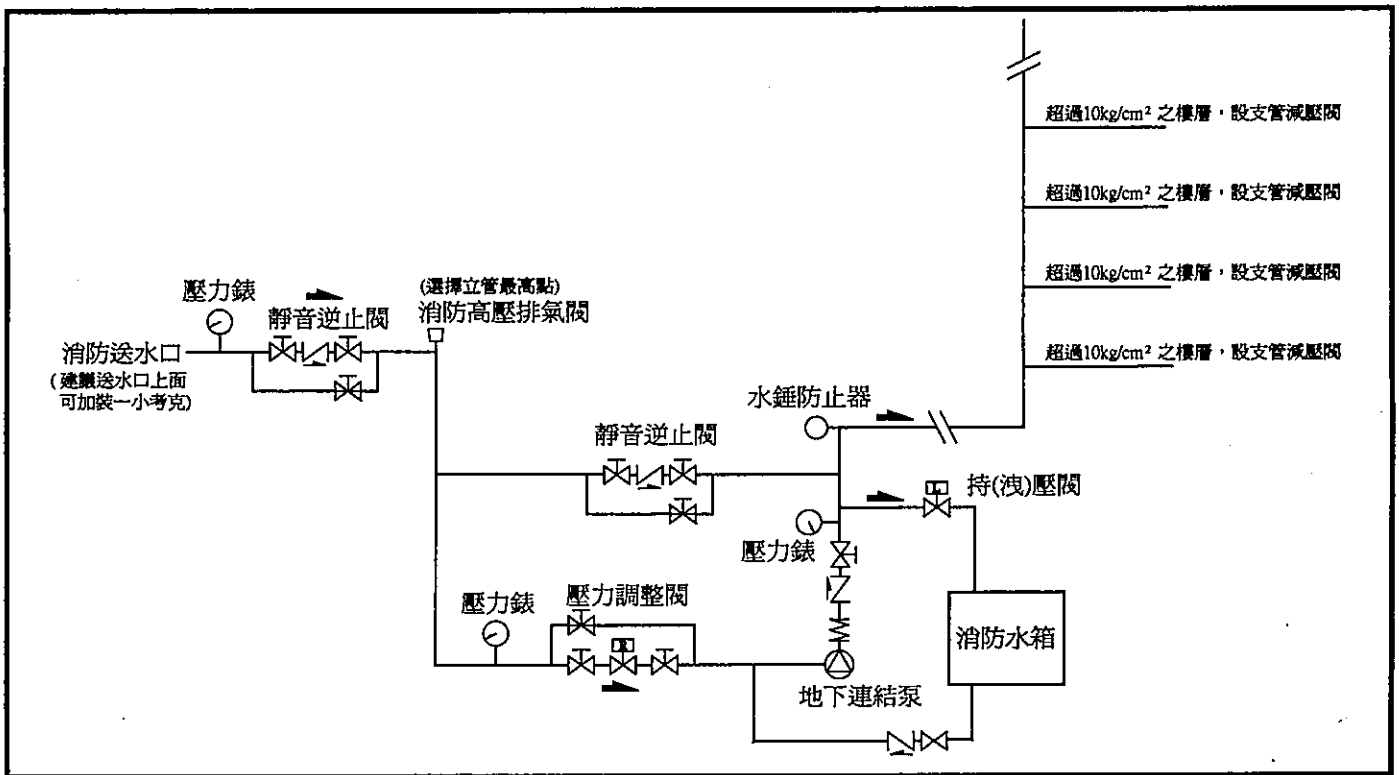

不銹鋼球塞閥(法蘭口)

型別	尺寸 材質	1/2"	3/4"	1"	1 1/4	1 1/2	2"	2 1/2	3"	4"	5"	6"	8"	10"	12"
10K	304	2360	2800	3800	5120	6400	7900	12400	14400	19200	34000	46000	85000	136000	204000
150LB	304	2480	2920	4000	5400	6800	8400	13000	16400	24000	41200	52000	98400	148000	236000
10K	316	3040	3680	5200	6800	8800	10800	16800	20200	27600	44000	62400	118000	188000	292000
150LB	316	3200	3920	5520	7200	9200	11400	18000	22000	32800	54000	72000	133000	208000	324000



不銹鋼球塞閥(牙口)



型別	尺寸 材質	1/4"	3/8"	1/2"	3/4"	1"	1 1/4"	1 1/2"	2	2 1/2"	3"	4"
1000WOG 單片式	304	340	370	480	560	780	970	1300	1820			
1000WOG 雙片式	304	460	460	504	652	840	1180	1680	2440	6000	7800	16800
1000WOG 單片式	316	352	400	552	640	872	1140	1440	2040			
1000WOG 雙片式	316	552	552	620	780	1160	1600	2320	3400	7600	10800	
1000WOG 三片式	316	740	740	940	1160	1680	2440	3400	4900	10000	14800	26000

不銹鋼閘閥(法蘭口)



單位：PC

型別	尺寸 材質	1/2"	3/4"	1"	1 1/4	1 1/2	2"	2 1/2	3"	4"	5"	6"	8"	10"	12"
10K	304	5400	5700	7200	10800	10800	13000	17000	22000	29000	45200	54000	86000	124000	192000
150LB	304	5400	5800	7200	11000	11000	13000	17200	23200	32400	47000	57000	93000	132000	196000
10K	316	6200	6600	8600	13600	13600	16800	22400	29000	38000	59200	72000	115200	168000	256000
150LB	316	6200	6600	8600	13800	13800	16800	22400	30000	44000	63200	78000	126000	180000	264000

不銹鋼橫式逆止閥



型別	尺寸 材質	1/2"	3/4"	1"	1 1/4	1 1/2	2"	2 1/2	3"	4"	5"	6"	8"	10"	12"
10K	304	3520	4000	5500	7400	7400	9520	13000	14400	25200	38400	48400	78000	148000	200000
150LB	304	3520	3960	5520	7320	7320	9500	13200	16000	30000	42000	50000	86400	155200	196000
10K	316	4000	4600	6500	8800	8800	11600	16000	18000	31600	50000	63200	101000	196000	264000
150LB	316	3960	4400	6600	8640	8640	11600	16000	19500	38000	52800	64000	112000	198000	268000

不銹鋼 Y 型過濾器



型別	尺寸 材質	1/2"	3/4"	1"	1 1/4	1 1/2	2"	2 1/2	3"	4"	5"	6"	8"	10"	12"
10K	304	3000	3360	5000	6600	6600	8400	12800	15200	21200	31600	44000	72000	132000	244000
150LB	304	3000	3400	5000	6800	6800	8400	12800	15600	25600	32000	48000	74000	136000	252000
10K	316	3600	4000	6000	8800	8800	11200	16000	20000	28000	44000	62000	100000	180000	300000
150LB	316	3600	4000	6000	8800	8800	11200	16000	20400	33600	44000	64000	100000	180000	300000



UW(-1) . UW(-1)NO 大流量系列

UW/UW-1 大流量系列

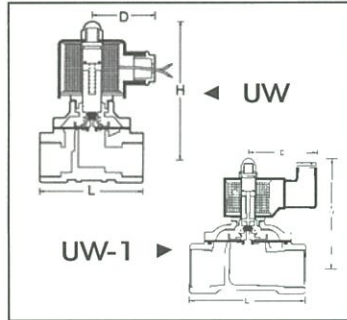

1. UW(-1) 系列為直複動連結膜片式通電開型。
2. 閥體材質：3/8"~1"為鍛造銅/1 1/4"~2"為鑄造銅。
3. 可在無壓差下，直接操作。
4. 定格電壓：AC 110V / AC 220V / DC 24V (50/60Hz)。
5. 電壓容許差：±10%，DC 電壓容許差：±1%。
6. 管徑接續規格：BSPT牙，如需其他規格(如：NPT . BSP)，可依客戶需求製作。
7. 其他特殊AC / DC電壓值，可依客戶需求製作。
8. 若使用流體為特殊流體，訂購時請註明流體種類(如：柴油、汽油)。
9. 流體溫度如須用至攝氏130 °C，另可訂製 Viton . Silicon 材質使用。

材 質 表	
零件名稱	使用材質
線 圈	特殊銅線H級
電 磁 管	不銹鋼
電磁活動鐵心	不銹鋼
彈 簧	不銹鋼
止 漏 塞 頭	NBR . Viton Silicon
膜 片	NBR . Viton Silicon
閥 體	鍛造銅 . 鑄造銅

DIN 線圈	型 號	配管 口徑	Cv	節流 口徑	流體溫度 (°C)	IN-OUT 入出口操作壓差範圍 kgf/cm ²			尺寸 (mm)			重量 (kg)
						空 氣	水	輕 油	L	H	D	
●	UW-10	3/8"	2.4	15 mm	-5°C ~ 80°C	0-7	0-5	0-5	70	100	50	0.9
●	UW-15	1/2"	4.5	15 mm	-5°C ~ 80°C	0-7	0-5	0-5	70	100	50	0.9
●	UW-20	3/4"	8.6	20 mm	-5°C ~ 80°C	0-7	0-5	0-5	73	102	50	1.0
●	UW-25	1"	12	25 mm	-5°C ~ 80°C	0-7	0-5	0-5	93	106	50	1.8
●	UW-35-1	1 1/4"	24	35 mm	-5°C ~ 80°C	0-7	0-5	0-5	125	140	58	3.2
●	UW-40-1	1 1/2"	28	40 mm	-5°C ~ 80°C	0-7	0-5	0-5	125	140	58	3.5
●	UW-50-1	2"	48	50 mm	-5°C ~ 80°C	0-7	0-5	0-5	167	170	58	5.4

UW-NO/UW-1NO 大流量系列

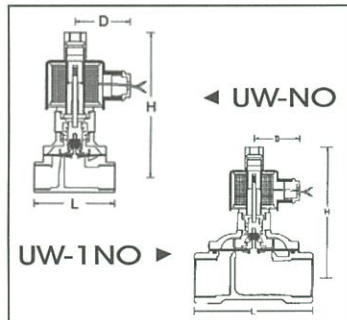

1. UW(-1)NO系列為直複動連結膜片式通電閉型。
2. 閥體材質：3/8"~1"為鍛造銅/1 1/4"~2"為鑄造銅。
3. 可在無壓差下，直接操作。
4. 定格電壓：AC 110V / AC 220V / DC 24V (50/60Hz)。
5. 電壓容許差：±10%，DC 電壓容許差：±1%。
6. 管徑接續規格：BSPT牙，如需其他規格(如：NPT . BSP)，可依客戶需求製作。
7. 其他特殊AC / DC電壓值，可依客戶需求製作。
8. 若使用流體為特殊流體，訂購時請註明流體種類(如：瓦斯、真空、柴油、汽油)。
9. 流體溫度如須用至攝氏130 °C，另可訂製 Viton . Silicon 材質使用。

材 質 表	
零件名稱	使用材質
線 圈	特殊銅線H級
電 磁 管	不銹鋼
電磁活動鐵心	不銹鋼
彈 簧	不銹鋼
止 漏 塞 頭	NBR . Viton Silicon
膜 片	NBR . Viton Silicon
閥 體	鍛造銅 . 鑄造銅

DIN 線圈	型 號	配管 口徑	Cv	節流 口徑	流體溫度 (°C)	IN-OUT 入出口操作壓差範圍 kgf/cm ²				尺寸 (mm)			重量 (kg)
						水	空 氣	瓦 斯	真 空	L	H	D	
●	UW-10-NO	3/8"	4.5	15 mm	-5°C ~ 80°C	0-5	0-7	0-7	0-10 ⁻³	70	100	50	1.1
●	UW-15-NO	1/2"	4.5	15 mm	-5°C ~ 80°C	0-5	0-7	0-7	0-10 ⁻³	70	100	50	1.1
●	UW-20-NO	3/4"	8.6	20 mm	-5°C ~ 80°C	0-5	0-7	0-7	0-10 ⁻³	73	102	50	1.2
●	UW-25-NO	1"	12	25 mm	-5°C ~ 80°C	0-5	0-7	0-7	0-10 ⁻³	93	106	50	2
●	UW-35-1NO	1 1/4"	24	35 mm	-5°C ~ 80°C	0-5	0-7	0-7	0-10 ⁻³	125	158	58	3.5
●	UW-40-1NO	1 1/2"	28	40 mm	-5°C ~ 80°C	0-5	0-7	0-7	0-10 ⁻³	125	158	58	3.8
●	UW-50-1NO	2"	48	50 mm	-5°C ~ 80°C	0-5	0-7	0-7	0-10 ⁻³	167	158	58	5.7

- ⚠ UW(-1).UW(-1)NO不適用以下情況之流體：
1. 溫度高時為液態，冷卻時為固態。
 2. 腐蝕性流體。
 3. 黏度超過20cst以上之流體。

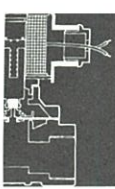

SUW(-1) . SUW(-1)NO 大流量系列

SUW/SUW-1 大流量系列

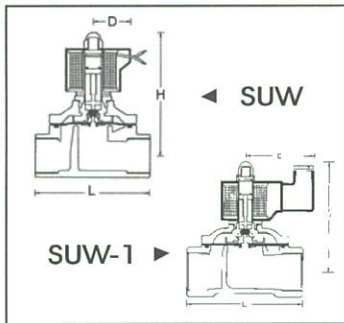

1. SUW(-1) 系列為直複動連結膜片式通電閉型。
2. 閥體材質為精密鑄造#316材質。
3. 可在無壓差下，直接操作。
4. 定格電壓：AC 110V / AC 220V / DC 24V (50/60Hz)。
5. 電壓容許差：±10%，DC 電壓容許差：±1%。
6. 管徑接續規格：BSPT牙，如需其他規格(如：NPT . BSP)，可依客戶需求製作。
7. 其他特殊AC / DC電壓值，可依客戶需求製作。
8. 若使用流體為特殊流體，訂購時請註明流體種類(如：瓦斯、真空、柴油、汽油)。
9. 流體溫度如須用至攝氏130 °C，另可訂製 Viton . Silicon 材質使用。

材 質 表	
零件名稱	使用材質
線 圈	特殊銅線H級
電 磁 管	不銹鋼
電磁活動鐵心	不銹鋼
彈 簧	不銹鋼
止 漏 塞 頭	NBR · Viton Silicon
膜 片	NBR · Viton Silicon
閥 體	不銹鋼#316

DIN 線圈	型 號	配管 口徑	Cv	節流 口徑	流體溫度 (°C)	IN-OUT 入口操作壓差範圍 kgf/cm ²				尺寸 (mm)			重量 (kg)
						水	空 氣	輕 油	真 空	L	H	D	
●	SUW-15#316	1/2"	4.5	15 mm	-5°C ~ 80°C	0-5	0-7	0-5		70	100	50	0.9
●	SUW-20#316	3/4"	8.6	20 mm	-5°C ~ 80°C	0-5	0-7	0-5		73	102	50	1.0
●	SUW-25#316	1"	12	25 mm	-5°C ~ 80°C	0-5	0-7	0-5		93	106	50	1.6
●	SUW-35-1	1 1/4"	24	35 mm	-5°C ~ 80°C	0-5	0-7	0-5		125	140	58	3.2
●	SUW-40-1	1 1/2"	28	40 mm	-5°C ~ 80°C	0-5	0-7	0-5		125	140	58	3.4
●	SUW-50-1	2"	48	50 mm	-5°C ~ 80°C	0-5	0-7	0-5		167	170	58	5.8

SUW-NO/SUW-1NO 大流量系列

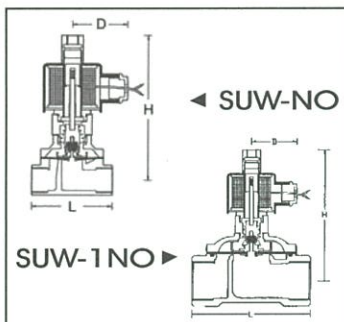

1. SUW(-1)NO 系列為直複動連結膜片式通電閉型。
2. 閥體材質為精密鑄造#316材質。
3. 可在無壓差下，直接操作。
4. 定格電壓：AC 110V / AC 220V / DC 24V (50/60Hz)。
5. 電壓容許差：±10%，DC 電壓容許差：±1%。
6. 管徑接續規格：BSPT牙，如需其他規格(如：NPT . BSP)，可依客戶需求製作。
7. 其他特殊AC / DC電壓值，可依客戶需求製作。
8. 若使用流體為特殊流體，訂購時請註明流體種類(如：瓦斯、真空、柴油、汽油)。
9. 流體溫度如須用至攝氏130 °C，另可訂製 Viton . Silicon 材質使用。

材 質 表	
零件名稱	使用材質
線 圈	特殊銅線H級
電 磁 管	不銹鋼
電磁活動鐵心	不銹鋼
彈 簧	不銹鋼
止 漏 塞 頭	NBR · Viton Silicon
膜 片	NBR · Viton Silicon
閥 體	精密鑄造#316

DIN 線圈	型 號	配管 口徑	Cv	節流 口徑	流體溫度 (°C)	IN-OUT 入口操作壓差範圍 kgf/cm ²				尺寸 (mm)			重量 (kg)
						水	空 氣	瓦 斯	真 空	L	H	D	
●	SUW-15-NO	1/2"	4.5	15 mm	-5°C ~ 80°C	0-5	0-7	0-7	0-10 ⁻³	70	126	50	1
●	SUW-20-NO	3/4"	8.6	20 mm	-5°C ~ 80°C	0-5	0-7	0-7	0-10 ⁻³	73	132	50	1.1
●	SUW-25-NO	1"	12	25 mm	-5°C ~ 80°C	0-5	0-7	0-7	0-10 ⁻³	93	139	50	1.7
●	SUW-35-1NO	1 1/4"	24	35 mm	-5°C ~ 80°C	0-5	0-7	0-7	0-10 ⁻³	125	154	58	3.5
●	SUW-40-1NO	1 1/2"	28	40 mm	-5°C ~ 80°C	0-5	0-7	0-7	0-10 ⁻³	125	156	58	3.7
●	SUW-50-1NO	2"	48	50 mm	-5°C ~ 80°C	0-5	0-7	0-7	0-10 ⁻³	167	175	58	6.1

- ⚠ SUW(-1).SUW(-1)NO不適用以下情況之流體：
1. 溫度高時為液態，冷卻時為固態。
 2. 腐蝕性流體。
 3. 黏度超過20cst以上之流體。

uni-D 電磁閥

型式	配管口徑	流量 孔徑	流體溫度	使用壓力 kgf/cm ² (bar)						定價	備註
				蒸氣	水	空氣	真空	油	瓦斯		
大流量水用電磁閥 1/2"3/4"1"為鍛造銅閥體。1-1/4"1-1/2"2"為鑄造銅閥體(1/2"-1"有供應防水線圈打折後加 NT\$50，DIN 線圈打折後加 NT\$100)											
UW-10	3/8"	15	-5°C-80°C		0-5	0.7		0-5		2200	
UW-15	1/2"	15			0-5	0.7		0-5		2200	
UW-20	3/4"	20			0-5	0.7		0-5		2700	
UW-25	1"	25			0-5	0.7		0-5		3800	
UW-35	1 1/4"	35			0-5	0.7		0-5		7000	
UW-40	1 1/2"	40			0-5	0.7		0-5		7000	
UW-50	2"	50			0-5	0.7		0-5		12000	
大流量不銹鋼精密鑄造#316 水用電磁閥(1/2"-1"供應 DIN 插頭式線圈打折後加 NT\$100)											
SUW-15	1/2"	15	-5°C-80°C		0-5	0.7		0-5		4000	
SUW-20	3/4"	20			0-5	0.7		0-5		4800	
SUW-25	1"	25			0-5	0.7		0-5		5600	
SUW-35	1 1/4"	35			0-5	0.7		0-5		10500	
SUW-40	1 1/2"	40			0-5	0.7		0-5		11500	
SUW-50	2"	50			0-5	0.7		0-5		16000	
大流量瓦斯、真空用電磁閥鍛造銅閥體(1/2"-1"有供應防水線圈打折後加 NT\$50，DIN 線圈打折後加 NT\$100)											
UG-10	3/8"	15	-5°C-80°C				0-10 ⁻³ Torr		0.7	2400	
UG-15	1/2"	15					0-10 ⁻³ Torr		0.7	2400	
UG-20	3/4"	20					0-10 ⁻³ Torr		0.7	2800	
UG-25	1"	25					0-10 ⁻³ Torr		0.7	3900	
UG-35	1 1/4"	35					0-10 ⁻³ Torr		0.7	7200	
UG-40	1 1/2"	40					0-10 ⁻³ Torr		0.7	7200	
UG-50	2"	50					0-10 ⁻³ Torr		0.7	12200	
大流量不銹鋼#304 高壓型電磁閥											
SUS-15 #304	1/2"	17	-5°C-185°C	0.5-15	0.5-15		0.5-10	0.5-10		6000	
SUS-20 #304	3/4"	17		0.5-15	0.5-15		0.5-10	0.5-10		7000	
SUS-25 #304	1"	22		0.5-15	0.5-15		0.5-10	0.5-10		8000	

鋼管價目表

CNS 6445			BSB 1387			CNS4626			ASTM A53B					
尺寸	厚度	鍍鋅剛管	尺寸	厚度	鍍鋅鋼管	尺寸	厚度	kg/支	尺寸	厚度	kg/支	尺寸	厚度	kg/支
1/2"	2.8	468	1/2"	2.6	468	1/2"	40S	7.2	1/2"	40S	7.2	12"	9.0	418.8
3/4"	2.8	576	3/4"	2.8	632	3/4"	40S	9.9	3/4"	40S	9.9	14"	9.0	461.52
1"	3.2	788	1"	3.2	884	1"	40S	14.28	1"	40S	14.28	16"	9.0	529.2
1 1/4"	3.5	1136	1 1/4"	3.6	1260	1 1/4"	40S	19.68	1 1/4"	40S	19.68	14"	7.5	386.29
1 1/2"	3.5	1456	1 1/2"	4.1	1592	1 1/2"	40S	22.86	1 1/2"	40S	22.86	16"	7.5	442.66
2"	3.8	1840	2"	4.1	2020	2"	40S	30.3	2"	40S	30.3	18"	7.5	499.03
2 1/2"	4.2	2600	2 1/2"	4.5	2860	2 1/2"	40S	52.74	2 1/2"	40S	50.28	18"	9.0	596.84
3"	4.2	3080	3"	4.5	3384	3"	40S	64.56	3"	40S	64.56	20"	7.5	555.4
4"	4.5	4200	4"	4.5	4632	4"	40S	90.06	4"	40S	90.06	20"	9.0	664.5
5"	4.5	5200	5"	4.5	5480	5"	40S	118.78	5"	40S	123.96	22"	9.0	732.12
6"	5.0	6600	6"	4.5	6600	6"	40S	157.12	6"	40S	160.2	24"	9.0	799.8
8"	5.5	171.54	8"	5.5	171.54	8"	40S	234.68	8"	40S	238.08	26"	9.0	867.42
10"	6.0	237.03	10"	5.5	213.12	10"	40S	336.71	10"	40S	344.52	28"	9.0	935.1
12"	6.4	295.56	12"	5.5	254.71	12"	40S	447.6	12"	40S	455.44	30"	9.0	1002.72
14"	7.5	386.29	14"	5.7	295.09	14"	40S	536.16	14"	40S	536.16	32"	9.0	1070.4
16"	7.5	442.66	16"	5.7	337.93	16"	40S	700.26	16"	40S	700.26	34"	9.0	1138.02
單位：支 1/2"~6" 1支 = 6.1M 8"~16"()元/kg 鍍鋅鋼管 ()%			單位：支 1/2"~6" 1支 = 6.1M 8"~16"()元/kg 鍍鋅鋼管()%			單位：支 1/2"~40" 1支=6M 1/2"~6" ()元/kg 8"~16"()元/kg 16"以上()元/kg 鍍鋅鋼管 ()								

無縫鋼管			無縫鍍鋅鋼管		EMT 無牙導電線鋼管			CNS 2606 RSG 厚導電線鋼管		C80.1 導電線鋼管	
尺寸	SCH40	SCH80	SCH40	SCH80	尺寸	厚度	3.66M/支	尺寸	6M/支	尺寸	4M/支
1/2"	7.74	9.72	7.74	9.72	E19	1.2	123	1/2"	418	1/2"	336
3/4"	1014	13.2	1014	13.2	E25	1.2	168	3/4"	504	3/4"	416
1"	15	19.44	15	19.44	E31	1.4	246	1"	683	1"	608
1 1/4"	20.34	26.82	20.34	26.82	E39	1.4	301	1 1/4"	876	1 1/4"	808
1 1/2"	24.3	32.64	24.3	32.64	E51	1.4	413	1 1/2"	991	1 1/2"	984
2"	32.64	44.88	32.64	44.88	E63	1.6	588	2"	1398	2"	1272
2 1/2"	51.78	68.46	51.78	68.46	E75	1.8	802	2 1/2"	1804	2 1/2"	2168
3"	67.74	91.62	67.74	91.62				3"	2208	3"	2832
4"	96.42	133.92	96.42	133.92				4"	3586	4"	4256
5"	130.62	185.4	130.62	185.4							
6"	169.56	255.36	169.56	255.36							
8"	355.3	387.6	355.3	387.6							
單位：1支 = 6M 6M ()kg			單位：1支 = 6M 6M ()kg		單位：1支 3.66M ()%			單位：1支 6M ()%		單位：1支 4M ()%	

鋼管價目表

CNS 6445			BSB 1387			CNS4626			ASTM A53B					
尺寸	厚度	鍍鋅鋼管	尺寸	厚度	鍍鋅鋼管	尺寸	厚度	kg/M	尺寸	厚度	kg/M	尺寸	厚度	kg/M
1/2"	2.8	76.72	1/2"	2.6	76.72	1/2"	40S	1.2	1/2"	40S	1.2	12"	9.0	69.8
3/4"	2.8	94.43	3/4"	2.8	103.61	3/4"	40S	1.65	3/4"	40S	1.65	14"	9.0	76.92
1"	3.2	129.18	1"	3.2	144.92	1"	40S	2.38	1"	40S	2.38	16"	9.0	88.2
1 1/4"	3.5	186.23	1 1/4"	3.6	206.56	1 1/4"	40S	3.28	1 1/4"	40S	3.28	14"	7.5	64.38
1 1/2"	3.5	238.69	1 1/2"	4.1	260.98	1 1/2"	40S	3.81	1 1/2"	40S	3.81	16"	7.5	73.78
2"	3.8	301.64	2"	4.1	331.15	2"	40S	5.05	2"	40S	5.05	18"	7.5	83.17
2 1/2"	4.2	426.23	2 1/2"	4.5	468.85	2 1/2"	40S	8.79	2 1/2"	40S	8.38	18"	9.0	99.47
3"	4.2	504.92	3"	4.5	554.75	3"	40S	10.76	3"	40S	10.76	20"	7.5	92.57
4"	4.5	688.52	4"	4.5	759.34	4"	40S	15.01	4"	40S	15.01	20"	9.0	110.75
5"	4.5	852.46	5"	4.5	898.36	5"	40S	20.66	5"	40S	20.66	22"	9.0	122.02
6"	5.0	1081.97	6"	4.5	1081.97	6"	40S	26.18	6"	40S	26.7	24"	9.0	133.3
8"	5.5	28.59	8"	5.5	28.59	8"	40S	39.11	8"	40S	39.68	26"	9.0	144.57
10"	6.0	39.5	10"	5.5	35.52	10"	40S	56.18	10"	40S	57.42	28"	9.0	155.85
12"	6.4	49.26	12"	5.5	42.45	12"	40S	74.6	12"	40S	75.81	30"	9.0	167.12
14"	7.5	64.38	14"	5.7	49.18	14"	40S	89.36	14"	40S	89.36	32"	9.0	178.4
16"	7.5	73.78	16"	5.7	56.32	16"	40S	116.71	16"	40S	116.71	34"	9.0	189.67
單位：M 1/2"~6" 8"~16"()元/kg 鍍鋅鋼管 ()%			單位：M 1/2"~6" 8"~16"()元/kg 鍍鋅鋼管 ()%			單位：M 1/2"~40" 1/2"~6" ()元/kg 8"~16"()元/kg 16"以上()元/kg 鍍鋅鋼管 ()								

無縫鋼管			無縫鍍鋅鋼管		EMT 無牙導電線鋼管			CNS 2606 RSG 厚導電線鋼管		C80.1 導電線鋼管	
尺寸	SCH40	SCH80	SCH40	SCH80	尺寸	厚度	M	尺寸	M	尺寸	M
1/2"	1.27	1.62	1.27	1.62	E19	1.2	33.61	1/2"	69.7	1/2"	84
3/4"	1.69	2.2	1.69	2.2	E25	1.2	45.90	3/4"	84	3/4"	104
1"	2.5	3.24	2.5	3.24	E31	1.4	67.21	1"	113.8	1"	152
1 1/4"	3.39	4.47	3.39	4.47	E39	1.4	82.24	1 1/4"	146	1 1/4"	202
1 1/2"	4.05	5.41	4.05	5.41	E51	1.4	112.84	1 1/2"	165.2	1 1/2"	246
2"	5.44	7.48	5.44	7.48	E63	1.6	160.66	2"	233	2"	318
2 1/2"	8.63	11.41	8.63	11.41	E75	1.8	219.13	2 1/2"	300.7	2 1/2"	542
3"	11.29	15.27	11.29	15.27				3"	368	3"	708
4"	16.07	22.32	16.07	22.32				4"	597.7	4"	1064
5"	21.77	30.9	21.77	30.9							
6"	28.26	42.56	28.26	42.56							
8"	43.55	64.6	43.55	64.6							
單位：M M ()kg			單位：M M ()kg		單位：M M ()%			單位：M M ()%		單位：M M ()%	

遠東機械 環氧樹脂粉體塗裝鋼管

1. 鋼管標準：

CNS6445、CNS4626、CNS2056、CNS2607、ASTM A53、BSB級、CNS6331不銹鋼管或客戶指定。

2. 特性：

- 可2M, 3M, 4M, 6M 廠內預製，大幅縮短現場切管、安裝時間。
- 廠內塗裝烘烤硬化，塗膜均勻光澤美觀，免除現場油漆塗佈不均、漏塗、流漆、滴漆現象。
- 屬固化塗料不須使用溶劑，減少大氣及環境汙染問題。
- 粉體塗裝具耐候、防蝕、環保、經濟、效率等各項特點，大幅提升工程品質與形象。

3. 種類：

外EPOXY粉體塗裝鋼管

5. 適用範圍：

- 消防管路系統
- 給排水系統
- 空調管路系統
- 配電系統

4. 用色說明：

空調、給水-----藍色
 消防系統配管---紅色
 污排水-----橘色
 其他客戶指定顏色

6. 產品端口形式：

- (1)平口端粉體塗裝鋼管
- (2)管端車牙粉體塗裝鋼管
- (3)滾溝接頭粉體塗裝鋼管

7. 塗膜溶出性：

試驗項目	要求值
濁度	<0.5度
色度	<1度
過錳酸鉀消耗量	<2mg/L
餘氯減量	<0.7ppm
酚類	<0.005mg/L
胺	無檢出
氰	無檢出
臭味及味道	無異常
適用於自來水管	

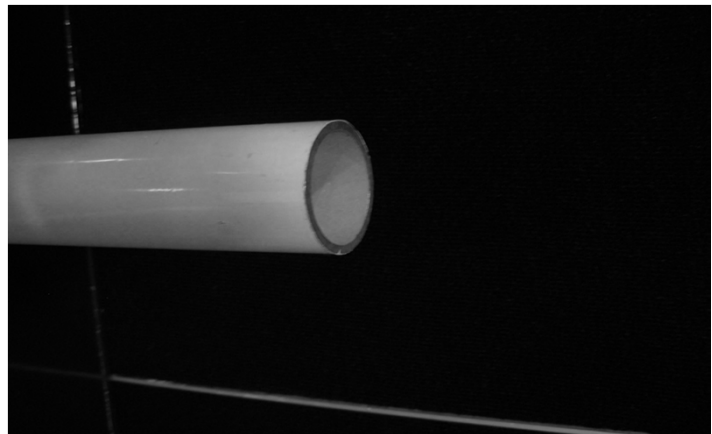

8. 品質：塗裝標準CNS 13273

膜厚	80 μ
硬度	鉛筆硬度H級以上
光澤度	ASTM D-523 60°C HEAO 80%u以上；平光10%~50%
耐衝擊性	ASTM G149mm鋼板，在25°C下，120kg-cm合格
屈撓性	140 φ 軸棒，6mm厚鋼板，在25°C，彎曲角度180°，測試無龜裂或剝落現象
耐磨性	ASTM D1044，CS-17，100g Weight load，1000cyc les測試，摩擦損失少於30mg
附著試驗	1mm，100格，透明膠帶一秒撕開，附著率100/100
鹽水噴霧試驗	ASTM B117，500小時，6mm擴散腐蝕，無起泡、變色情形

CNS 6445

管口徑	管 材	粉體塗裝	噴 漆	車 牙	裁 切	滾 溝	樓層編號
單位	NT\$	NT\$/M	NT\$/M	NT\$/M	NT\$/M	NT\$/M	NT\$/M
1/2"	83	36	18	40	0	0	6
3/4"	102	46	24	60	0	0	6
1"	126	56	30	80	0	0	10
1 1/4"	182	68	38	120	0	0	14
1 1/2"	233	78	44	120	0	0	14
2"	294	96	54	140	0	0	20
2 1/2"	416	120	64	240	0	90	30
3"	493	140	78	300	48	100	30
4"	630	180	100	360	80	110	40
5"	780	224	124	800	120	140	60
6"	990	266	148	1000	200	140	60

CNS 4626

	管 材	粉體塗裝	噴 漆	車 牙	裁 切	滾 溝	樓層編號
單位	NT\$/M	NT\$/M	NT\$/M	NT\$/M	NT\$/M	NT\$/M	NT\$/M
1/2"	84	36	18	40	0	0	6
3/4"	110	46	24	60	0	0	6
1"	140	56	30	80	0	0	10
1 1/4"	202	68	38	120	0	0	14
1 1/2"	246	78	44	120	0	0	14
2"	290	96	54	140	0	0	20
2 1/2"	516	120	64	240	0	90	30
3"	668	140	78	300	48	100	30
4"	914	180	100	360	80	110	40
5"	1248	224	124	800	120	140	60
6"	1588	266	148	1000	200	140	60

CNS6331 G3124 · JIS3459 一般配管用不銹鋼管

單位：元/每米

() %

呎吋稱呼 平均外徑	厚度	單價	SCH.#	呎吋稱呼 平均外徑	厚度	單價	SCH.#	呎吋稱呼 平均外徑	厚度	單價	SCH.#
1/8" 10.5mm	1.2m/m	48	10s	2" 60.5mm	2.0m/m	353		5" 139.8mm	2.0m/m	1065	
	1.5m/m	60	20s		2.5m/m	429			2.5m/m	1250	
1/4" 13.8mm	1.2m/m	59	5s		2.8m/m				3.0m/m		
	1.5m/m	73			3.0m/m	501	10s		3.4m/m	1530	10s
3/8" 17.3mm	1.5m/m	93			3.5m/m	621	20s		4.0m/m	1680	
	2.0m/m	110	20s		3.9m/m				5.0m/m	2265	20s
1/2" 20.4mm	2.0m/m	112			4.0m/m	679	40s		6.0m/m	2695	
	2.5m/m	133			2.0m/m	447			6.6m/m		40s
1/2" 21.7mm	2.0m/m	120		2-1/2" 76.3mm	2.5m/m	545		6" 165.2mm	3.0m/m	1485	
	2.1m/m		10s		3.0m/m	638	10s		3.5m/m	1815	10s
	2.5m/m	143	20s		3.5m/m	792	20s		4.0m/m	1990	
	2.8m/m	180	40s		4.0m/m	862			5.0m/m	2690	20s
3/4" 27.2mm	2.0m/m	151			5.0m/m	1185			6.0m/m	3205	
	2.1m/m		10s		5.2m/m		40s		7.1m/m		40s
	2.5m/m	182	20s		2.0m/m	523			3.0m/m	1970	
1" 34mm	2.5m/m	227	40s		3" 89.1mm	2.5m/m	638			8" 216.3mm	3.5m/m
	2.0m/m	195		3.0m/m		748	10s	4.0m/m	2645		10s
	2.5m/m	236		3.5m/m		930		5.0m/m	3545		
	2.8m/m		10s	4.0m/m		1014	20s	6.0m/m	4235		
	3.0m/m	274	20s	5.0m/m		1395		6.5m/m	4610		20s
	3.5m/m	332	40s	5.5m/m		1470	40s	8.2m/m			40s
	3.4m/m	361		2.0m/m		600		3.0m/m	2645		
	4.0m/m	361		2.5m/m		732		3.5m/m	3240		
1-1/4" 42.7mm	2.0m/m	248		3-1/2" 101.6mm	3.0m/m	858	10s	10" 267mm	4.0m/m	3560	10s
	2.5m/m	300			3.5m/m	1068			5.0m/m	4605	
	2.8m/m		10s		4.0m/m	1165	20s		6.0m/m	5505	
	3.0m/m	350	20s		5.0m/m	1550			6.5m/m	5985	20s
	3.5m/m	427			5.7m/m		40s		9.3m/m		40s
	3.6m/m				6.0m/m	1840			3.0m/m	3155	
	4.0m/m	465	40s		2.0m/m	676			3.5m/m	3870	
	2.0m/m	281			4" 114.3mm	2.5m/m	826			12" 318.5mm	4.0m/m
2.5m/m	341		3.0m/m	969		10s	4.5m/m	4950	10s		
2.8m/m		10s	3.5m/m	1206			5.0m/m	5500			
3.0m/m	398	20s	4.0m/m	1316		20s	6.0m/m	6580			
3.5m/m	491		5.0m/m	1750			6.5m/m	7129	20s		
3.7m/m			6.0m/m	2080		40s	10.3m/m		40s		
4.0m/m	536	40s									

CNS13392 G3258 · JIS G3448 不銹鋼壓著管

代號：YP

1 支=6 公尺 () %

稱 呼	外 徑 m/m	厚 度 m/m	頭 足(kg/m)	價 格	
				每公尺	6 公尺
1/2	13	15.88	0.301	116	696
3/4	20	22.22	0.529	189	1134
1	25	28.58	0.687	246	1476
1-1/4	30	34.00	0.980	343	2058
1-1/2	40	42.70	1.240	434	2604
2	50	48.60	1.420	497	2982
2-1/2	60	60.50	2.200	762	4572

不銹鋼發泡 PE 被覆加工牌價表

單位：M

壓接管		FK-01 明管型			FK-02 暗管型		FK-03 冷水防蝕管	
		PE 發泡 被覆厚度	耐燃 單價	非耐燃 單價	PE 發泡 被覆厚度	單價	PE 被覆厚度	單價
管徑	管厚度							
1/2"	0.8mm	6.0mm	54	45	2.6mm	12	0.8mm	10
3/4"	1.0mm	6.0mm	70	57	2.8mm	17	0.8mm	12
1"	1.0mm	6.0mm	88	72	3.3mm	26	0.8mm	16
1- 1/4"	1.2mm	7.0mm	163	130	3.5mm	57	0.8mm	43
1-1/2"	1.2mm	8.0mm	225	186	4.0mm	79	0.8mm	57
2"	1.2mm	9.0mm	250	208	4.0mm	93	0.8mm	79
2-1/2"	1.5mm	9.0mm	300	245	4.0mm	108	0.8mm	100

車牙管		FK-11 明管型			FK-12 暗管型		FK-13 冷水防蝕管	
		PE 發泡 被覆厚度	耐燃 單價	非耐燃 單價	PE 發泡 被覆厚度	單價	PE 被覆厚度	單價
管徑	管外徑							
1/2"	21.7mm	6.0mm	60	50	2.6mm	15	0.8mm	12
3/4"	27.2mm	6.0mm	78	65	2.8mm	20	0.8mm	15
1"	34.0mm	6.0mm	96	80	3.3mm	32	0.8mm	24
1- 1/4"	42.7mm	8.0mm	207	165	3.5mm	79	0.8mm	58
1-1/2"	48.6mm	9.0mm	250	208	4.0mm	100	0.8mm	80
2"	60.5mm	9.0mm	319	255	4.0mm	129	0.8mm	93
2-1/2"	76.3mm	10.0mm	425	340	4.0mm	158	0.8mm	115
3"	89.1mm	10.0mm	480	390	5.0mm	200	0.8mm	157
4"	114.3mm	10.0mm	600	500	5.0mm	257	0.8mm	214

※ 如有以上未列之被覆厚度，歡迎來電洽詢

管類

聚乙烯被覆鋼管製造流程: PE COATED STEEL PIPE PRODUCTION FLOW CHART

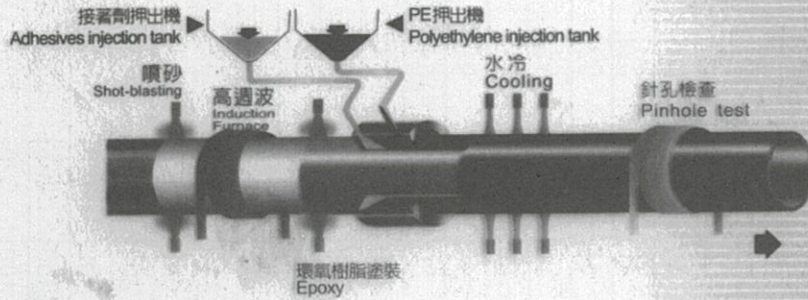

聚乙烯被覆鋼管結構圖 PE COATED STEEL PIPE STRUCTURE

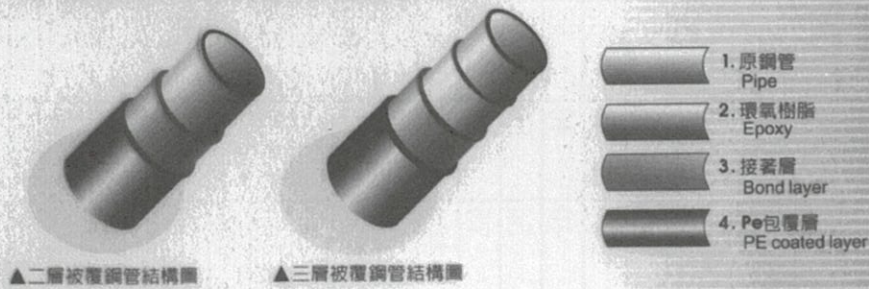

包覆鋼管結構圖 COATED STEEL PIPE STRUCTURE

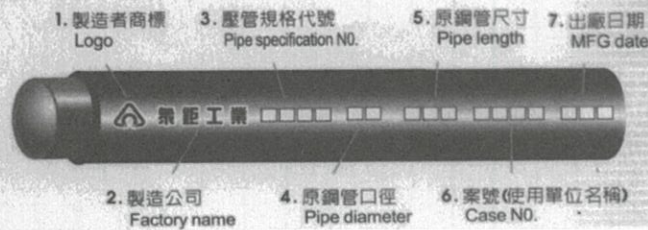

鋼管高密度聚乙烯防蝕被覆加工牌價表

管徑	被覆厚度	單價	管徑	被覆厚度	單價
1/2"	1.5mm	77	4"	2.0mm	220
3/4"	1.5mm	83	5"	2.0mm	275
1"	1.5mm	94	6"	2.0mm	330
1 1/4"	1.5mm	110	8"	2.5mm	462
1 1/2"	1.5mm	127	10"	2.5mm	594
2"	1.5mm	138	12"	2.5mm	715
2 1/2"	1.5mm	154	14"	2.5mm	825
3"	1.5mm	176	16"	2.5mm	1045

聚乙烯被覆鋼管結構圖



聚乙烯被覆鋼管依據 JIS G3469 CNS 13638 G3260 規範生產檢驗

不銹鋼管及配件淨油處理費用(AP品淨油專用)

尺寸		PIPE/M				E-Tee/R-Tee				Elbow 焊頸法蘭 Reducer				法蘭片 盲板/CAP				外拋#180 PIPE/M
		牌價				牌價				牌價				牌價				牌價
		10S以下	20S	40S	80S	10S以下	20S	40S	80S	10S以下	20S	40S	80S	10S以下	20S	40S	80S	5S
tube 3/8"		130	130	169	234	50	50	65	90	30	30	39	54	30	30	39	54	50
tube 1/2"		150	150	195	270	50	50	65	90	30	30	39	54	30	30	39	54	50
tube 3/4"		160	160	208	288	50	50	65	90	40	40	52	72	40	40	52	72	50
15A	1/2"	180	180	234	324	50	50	65	90	40	40	52	72	40	40	52	72	50
20A	3/4"	210	210	273	378	60	60	78	108	40	40	52	72	40	40	52	72	50
25A	1"	240	240	312	432	70	70	91	126	50	50	65	90	50	50	65	90	50
32A	1-1/4"	270	270	351	486	90	90	117	162	75	75	98	135	60	60	78	108	60
40A	1-1/2"	300	300	390	540	110	110	143	198	100	100	130	180	70	70	91	126	70
50A	2"	320	320	416	576	130	130	169	234	120	120	156	216	80	80	104	144	80
65A	2-1/2"	360	360	648	900	160	160	288	400	135	135	243	338	90	90	162	225	100
80A	3"	400	520	720	1000	220	286	396	550	145	189	261	363	100	130	180	250	120
100A	4"	450	585	810	1125	300	390	540	750	160	208	288	400	110	143	198	275	150
125A	5"	500	650	900	1388	350	455	630	975	230	299	414	650	125	163	225	348	
150A	6"	550	715	990	1650	400	520	720	1200	300	390	540	900	140	182	252	420	
200A	8"	720	936	1296	2160	660	858	1188	1980	550	715	990	1650	200	260	360	600	
250A	10"	1000	1300	1800	3000	880	1144	1584	2640	800	1040	1440	2400	250	325	450	750	
300A	12"	1200	1560	2160	3600	1200	1560	2160	3600	1000	1300	1800	3000	300	390	540	900	
350A	14"	1360	1768	2448	4080	1400	1820	2520	4200	1250	1625	2250	3750	350	455	630	1050	
400A	16"	1580	2054	2844	4740	1600	2080	2880	4800	1400	1820	2520	4200	400	520	720	1200	
450A	18"	1720	2236	3096	5160	1720	2236	3096	5160	1600	2080	2880	4800	600	780	1080	1800	
500A	20"	1930	2509	3474	5790	1930	2509	3474	5790	1448	1882	2606	4344	800	1040	1440	2400	
550A	22"	2200	2860	3960	6600	2200	2860	3960	6600	1800	2340	3240	5400	1000	1300	1800	3000	
600A	24"	3000	3900	5400	9000	3000	3900	5400	9000	2250	2925	4050	6750	1500	1950	2700	4500	

PS: 附油脂殘留檢測報告保證值<0.1mg/ft²

有縫不銹鋼管內外拋光價格表 #250

呼徑	管內拋光 6Mx1PC	焊道拉光 6Mx1PC	管外拋光 6Mx1PC				呼徑	管內拋光 6Mx1PC	焊道拉光 6Mx1PC	管外拋光 6Mx1PC			
			構造管	配管2.8以下	配管3.0以下	毛絲面				構造管	配管2.8以下	配管3.0以下	毛絲面
1"	620		125	150	190	228	5"	2100	3300		1125	1350	1625
1 1/4"	620		156	188	235	282	6"	2520	3720		1350	1500	1800
1 1/2"	620		188	225	280	336	8"	3360	4560			1750	2100
2"	840		250	300	375	450	10"	4200	5400			2188	2626
2 1/2"	1050		313	375	470	564	12"	5000	6200			2625	3150
3"	1260		375	450	560	672	14"	5880	7080			4375	5250
3 1/2"	1470			525	655	786	16"	6720	7920			5250	6300
4"	1680			600	750	900							

無縫不銹鋼管內外拋光價格表 #300

呼徑	管內拋光 1M 價格			管外拋光 6M 價格			呼徑	管內拋光 1M 價格			管外拋光 6M 價格		
	10S.20S	40S.80S	160S	10S.20S	40S.80S	160S		10S.20S	40S.80S	160S	10S.20S	40S.80S	160S
1"	188	263	360	188	228	375	5"	900	1270	1750	1500	1885	2626
1 1/4"	278	395	540	238	286	473	6"	1050	1490	2050	1875	2210	3375
1 1/2"	315	455	630	282	345	563	8"	1365	1925	2650	2500	2925	4313
2"	390	550	760	375	455	750	10"	1705	2405	3300	3125	3738	5175
2 1/2"	488	685	950	469	572	938	12"	2046	3005	3960	3750	4485	6038/
3"	563	790	1080	563	683	1125	14"	2387	3370	4620	4375	5233	6900
3 1/2"	675	965	1320	657	800	1313	16"	2730	3850	5280	5000	5980	8280
4"	713	1050	1480	750	910	1500							

註：1.凡內徑 3mm 以上，長度 12M 皆可加工

2.本表內外拋光等級以電腦測試為基準，每增加#50 費用增加 10%

3.本公司加工品質穩定，交貨迅速

4.全部以 6M 為準，短管另詢價，價格較高

無縫彎頭、大小頭，(三通 x1 1/3)內外拋光價格表 #300

呼徑	10S.20Sx1PC		40S.80Sx1PC		160Sx1PC		呼徑	10S.20Sx1PC		40S.80Sx1PC		160Sx1PC	
	內拋	外拋	內拋	外拋	內拋	外拋		內拋	外拋	內拋	外拋	內拋	外拋
1"	105	45	140	60	175	75	5"	850	375	935	413	1029	454
1 1/4"	132	56	175	75	219	94	6"	1020	450	1122	495	1234	545
1 1/2"	158	68	210	90	263	113	8"	1360	600	1796	660	1646	726
2"	210	90	280	120	350	150	10"	1700	750	1870	825	2057	905
2 1/2"	263	113	350	150	438	188	12"	2040	900	2244	990	2468	1089
3"	315	135	420	180	525	225	14"	2380	1050	2618	1155	2880	1271
3 1/2"	363	158	490	210	613	263	16"	2720	1200	2992	1320	3291	1452
4"	680	300	748	330	823	363							

構造用圓管 AISI 304

稱呼	外徑m/m	厚度 m/m	每公尺價格	稱呼	外徑m/m	厚度 m/m	每公尺價格	稱呼	外徑m/m	厚度 m/m	每公尺價格
3/8	9.5	0.4	16.00	3/4	19	0.7	45.00	11/4	31.8	0.8	85.00
		0.5	19.00			0.8	51.00			0.9	95.00
		0.6	21.00			0.9	57.00			1.0	105.00
		0.7	24.00			1.0	63.00			1.2	114.00
		0.8	28.00			1.2	69.00			1.5	139.00
		0.9	32.00			1.5	86.00			2.0	186.00
		1.0	35.00			2.0	110.00			0.7	90.00
1/2	12.7	0.4	21.00	7/8	22.2	0.4	35.00	11/2	38.1	0.8	102.00
		0.5	25.00			0.5	42.00			0.9	114.00
		0.6	29.00			0.6	48.00			1.0	125.00
		0.7	32.00			0.7	55.00			1.2	137.00
		0.8	35.00			0.8	60.00			1.5	167.00
		0.9	40.00			0.9	67.00			2.0	225.00
		1.0	44.00			1.0	74.00			2.5	281.00
		1.2	48.00			1.2	81.00			3.0	336.00
5/8	15.9	0.4	26.00	1	25.4	2.0	132.00	2	50.8	0.9	155.00
		0.5	31.00			0.4	40.00			1.0	170.00
		0.6	34.00			0.5	48.00			1.2	182.00
		0.7	38.00			0.6	55.00			1.5	222.00
		0.8	43.00			0.7	63.00			2.0	300.00
		0.9	49.00			0.8	69.00			2.5	377.00
		1.0	54.00			0.9	77.00			3.0	453.00
		1.2	59.00			1.0	84.00			1.2	233.00
3/4	19	0.4	31.00	11/4	31.8	1.2	92.00	21/2	63.5	1.5	285.00
		0.5	37.00			1.5	112.00			2.0	378.00
		0.6	40.00			2.0	151.00			2.5	476.00
						3.0	573.00				
						0.7	75.00	3	76.2	1.5	353.00

不銹鋼方管 AISI 304

1/2	0.6	41.00	3/4	0.9	67.00	11/4	1.5	167.00	
	0.7	45.00		1.0	74.00	11/2	0.9	155.00	
	0.8	50.00		1.2	88.00		1.0	170.00	
	0.9	59.00		1.5	107.00		1.2	182.00	
	1.0	64.00		0.7	75.00		1.5	222.00	
	1.2	69.00		0.8	85.00	2.0	324.00		
5/8	0.6	45.00	1	0.9	95.00	2	1.2	251.00	
	0.7	50.00		1.0	105.00		1.5	309.00	
	0.8	56.00		1.2	114.00		2.0	407.00	
	0.9	64.00		1.5	139.00		3.0	673.00	
	1.0	70.00		0.7	90.00		60m/m*60m/m	2.0	600.00
	1.2	76.00		0.8	102.00		70m/m*70m/m	2.0	725.00
3/4	0.6	48.00	11/4	0.9	114.00	80m/m*80m/m	2.0	800.00	
	0.7	55.00		1.0	125.00	90m/m*90m/m	2.0	900.00	
	0.8	60.00		1.2	137.00		3.0	1240.00	







不銹鋼扁管 AISI 304

10m/m*20m/m	0.6	45.00	15m/m*30m/m	1.0	108.00	30m/m*60m/m	1.5	315.00
	0.7	51.00	20m/m*40m/m	1.2	117.00	40m/m*80m/m	2.0	430.00
	0.8	57.00		0.9	129.00		1.5	405.00
	0.9	63.00		1.0	140.00	2.0	500.00	
1.2	104.00	1.2		152.00	45m/m*75m/m	1.5	405.00	
13m/m*26m/m	0.9	89.00	25m/m*50m/m	1.5	182.00	45m/m*95m/m	2.0	500.00
	1.0	96.00		1.2	205.00		2.0	625.00
15m/m*30m/m	0.9	100.00		1.5	245.00		3.0	860.00









AP環氧樹脂塗裝鑄鐵管價目表

直管 折
配件 折

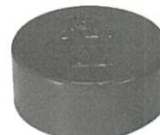
P1

名稱	規格	價格(NT\$)	單位	名稱	規格	價格(NT\$)	單位
 直管	1 1/2"	720	M	 斜梯	4"	1,900	PCS
	2"	750	M		5"*2"	2,240	PCS
	3"	1,030	M		5"*3"	2,640	PCS
	4"	1,560	M		5"*4"	2,900	PCS
	5"	1,860	M		5"	2,900	PCS
	6"	2,300	M		6"*2"	3,280	PCS
	8"	3,720	M		6"*3"	3,280	PCS
	10"	6,120	M		6"*4"	3,280	PCS
	12"	11,000	M		6"*5"	3,600	PCS
 90度彎頭	1 1/2"	500	PCS		6"	4,050	PCS
	2"	500	PCS		8"*3"	7,200	PCS
	3"	850	PCS		8"*4"	7,500	PCS
	4"	1,330	PCS		8"*5"	8,000	PCS
	5"	2,060	PCS		8"*6"	9,400	PCS
	6"	2,640	PCS		8"	11,800	PCS
	8"	7,560	PCS		10"*4"	13,000	PCS
	10"	14,680	PCS		10"*6"	14,600	PCS
	12"	42,000	PCS		10"*8"	16,600	PCS
 45度彎頭	1 1/2"	460	PCS		10"	17,200	PCS
	2"	460	PCS	12"	38,000	PCS	
	3"	650	PCS	 順水梯	1 1/2"	660	PCS
	4"	1,010	PCS		2"* 1 1/2"	700	PCS
	5"	1,460	PCS		2"	700	PCS
	6"	2,170	PCS		3"*2"	900	PCS
	8"	6,300	PCS		3"	1,100	PCS
	10"	9,900	PCS		4"*2"	1,250	PCS
	12"	20,000	PCS		4"*3"	1,600	PCS
 斜梯	2"*1/2"	900	PCS		4"	1,800	PCS
	2"	900	PCS		5"*2"	2,700	PCS
	3"*2"	1,060	PCS		5"*3"	2,700	PCS
	3"	1,350	PCS	5"*4"	2,700	PCS	
	4"*2"	1,610	PCS	5"	3,400	PCS	
	4"*3"	1,750	PCS	6"*2"	3,810	PCS	

管類

名稱	規格	價格(NT\$)	單位	名稱	規格	價格(NT\$)	單位	
 順水梯	6"*3"	3,810	PCS	 P存水彎	2"	1,150	PCS	
	6"*4"	3,810	PCS		3"	2,050	PCS	
	6"*5"	4,850	PCS		4"	3,850	PCS	
	6"	4,850	PCS					
	 管帽	8"*4"	8,800	PCS	 歐規壓環接頭 CE-EN877認證	1 1/2"	560	PCS
		8"*6"	9,400	PCS		2"*1 1/2"	1,280	PCS
		8"	11,200	PCS		2"	630	PCS
2"		420	PCS	3"		770	PCS	
3"		510	PCS	4"		990	PCS	
4"		750	PCS	5"		1,370	PCS	
5"		980	PCS	6"		1,790	PCS	
6"	1,220	PCS	8"	2,450		PCS		
8"	2,885	PCS	10"	3,920		PCS		
10"	5,400	PCS	12"	20,800		PCS		
12"	10,800	PCS	美規壓環接頭	1 1/2"		430	PCS	
 清潔口	2"	820	PCS	 IAPMO UPC認證		2"*1 1/2"	980	PCS
	3"	1,080	PCS		2"	480	PCS	
	4"	1,340	PCS		3"	590	PCS	
	5"	2,780	PCS		4"	760	PCS	
	6"	2,780	PCS		5"	980	PCS	
	8"	4,820	PCS		6"	1,260	PCS	
 大小頭	2"*1/2"	380	PCS		 美規加重型 壓環接頭	8"	1,880	PCS
	3"*2"	380	PCS			10"	2,800	PCS
	4"*2"	500	PCS			12"	16,000	PCS
	4"*3"	580	PCS			3"(PVC)	1,100	PCS
	5"*3"	900	PCS			4"(PVC)	1,400	PCS
	5"*4"	1,060	PCS			2"	1,000	PCS
	6"*2"	1,430	PCS	3"		1,100	PCS	
	6"*3"	1,600	PCS	4"		1,300	PCS	
	6"*4"	1,700	PCS	5"		2,600	PCS	
	6"*5"	1,850	PCS	6"		3,400	PCS	
	8"*4"	2,370	PCS	8"		4,400	PCS	
	8"*6"	2,800	PCS	10"		5,000	PCS	
	10"*4"	4,000	PCS	12"	16,000	PCS		
	10"*6"	5,050	PCS					
10"*8"	5,550	PCS						
12"*10"	8,400	PCS						

PVC 塑膠管

()%

標稱管徑		平均外徑	近似內徑	近似厚度	長 度	每米牌價	每支牌價
A27	1"	34m/m	30m/m	2.0m/m	4M	14.48	57.90
B27	1"	34m/m	27m/m	3.5m/m	4M	24.08	96.30
A35	1 1/4"	42m/m	38m/m	2.0m/m	4M	18.10	72.40
B35	1 1/4"	42m/m	35m/m	3.5m/m	4M	30.48	121.90
S65	2 1/2"	76m/m	72m/m	2.0m/m	4M	33.35	133.40

依據 CNS 1298 聚氧 to 烯塑膠硬質管於 106 年 02 月 18 日修改規範取消部規格，以上規格不再印有標示”(修定日期:96 年 1 月 18 日)”說明依據舊版規範生產。

標稱管徑		平均外徑	近似內徑	近似厚度	長 度	每米牌價	每支牌價
E13	3/8"	18m/m	14m/m	2.0m/m	4M	7.23	28.90
W13	3/8"	18m/m	13m/m	2.5m/m	4M	9.00	36.00
E16	1/2"	22m/m	18m/m	2.0m/m	4M	9.05	36.20
W16	1/2"	22m/m	16m/m	3.0m/m	4M	12.90	51.60
E20	3/4"	26m/m	22m/m	2.0m/m	4M	10.85	43.40
W20	3/4"	26m/m	20m/m	3.0m/m	4M	15.60	62.40
E28	1"	34m/m	28m/m	3.0m/m	4M	21.03	84.10
W25	1"	32m/m	25m/m	3.5m/m	4M	22.58	90.30
E35	1 1/4"	42m/m	35m/m	3.5m/m	4M	30.48	121.90
W30	1 1/4"	38m/m	31m/m	3.5m/m	4M	27.25	109.00
A40	1 1/2"	48m/m	44m/m	2.0m/m	4M	20.80	83.20
E41	1 1/2"	48m/m	41m/m	3.5m/m	4M	35.20	140.80
B40	1 1/2"	48m/m	40m/m	4.0m/m	4M	39.55	158.20
W40	1 1/2"	48m/m	40m/m	4.0m/m	4M	40.45	161.80
A50	2"	60m/m	56m/m	2.0m/m	4M	26.23	104.90
E52	2"	60m/m	52m/m	4.0m/m	4M	50.63	202.50
W50	2"	60m/m	51m/m	4.5m/m	4M	56.65	226.60
A65	2 1/2"	76m/m	71m/m	2.5m/m	4M	41.25	165.00
B65	2 1/2"	76m/m	67m/m	4.5m/m	4M	72.90	291.60
A80	3"	89m/m	83m/m	3.0m/m	4M	58.50	234.00
E80	3"	89m/m	78m/m	5.5m/m	4M	104.05	416.20
B.W80	3"	89m/m	77m/m	6.0m/m	4M	110.10	440.40
B.W80	3"	89m/m	77m/m	6.0m/m	4M	110.10	440.40
A90	3 1/2"	100m/m	94m/m	3.5m/m	4M	73.80	295.20
A100	4"	114m/m	107m/m	3.5m/m	4M	88.00	352.00
ES-1 100	4"	114m/m	106m/m	4.0m/m	5M	103.00	515.00

**※專業 PVC 透水管
加工鑽孔請來電詢**

PVC 塑膠管

()%

標稱管徑		平均外徑	近似內徑	近似厚度	長 度	每米牌價	每支牌價
W100	4"	114m/m	100m/m	7.0m/m	5M	171.00	855.00
筏 125	5"	140 m/m	133m/m	3.5m/m	5M	108.20	541.00
A125	5"	140m/m	131m/m	4.5m/m	5M	138.10	690.50
B125	5"	140m/m	125m/m	7.0m/m	5M	232.20	1116.00
W125	5"	140m/m	125m/m	7.0m/m	5M	232.20	1116.00
筏 150	6"	165m/m	157m/m	4.0m/m	5M	145.86	729.30
A150	6"	165m/m	154m/m	5.5m/m	5M	198.68	993.40
B150	6"	165m/m	146m/m	9.0m/m	6M	335.05	2010.30
W150	6"	165m/m	146m/m	9.0m/m	6M	335.10	2010.60
筏 200	8"	216m/m	206m/m	5.0m/m	6M	238.70	1432.20
A200	8"	216m/m	202m/m	7.0m/m	6M	331.44	1988.60
B200	8"	216m/m	194m/m	10.5m/m	6M	506.50	3039.00
E200	8"	216m/m	194m/m	10.5m/m	6M	517.00	3102.00
W200	8"	216m/m	194m/m	11.0m/m	6M	527.95	3167.70
筏 250	10"	267m/m	253m/m	7.0m/m	6M	411.70	2470.20
A250	10"	267m/m	250m/m	8.5m/m	6M	497.76	2986.60
B250	10"	267m/m	241m/m	13.0m/m	6M	774.50	4647.00
W250	10"	267m/m	239m/m	13.5m/m	6M	805.95	4835.70
筏 300	12"	318m/m	301m/m	8.5m/m	6M	593.02	3,558.10
A300	12"	318m/m	298m/m	10.0m/m	6M	697.73	4,186.40
B300	12"	318m/m	286m/m	15.5m/m	6M	1098.50	6591.00
W300	12"	318m/m	284m/m	16.0m/m	6M	1148.80	6892.80
筏 350	14"	370m/m	350m/m	10.0m/m	6M	811.50	4,869.00
A350	14"	370m/m	348m/m	10.5m/m	6M	906.00	5,436.00
B350	14"	370m/m	332m/m	18.0m/m	6M	1,526.00	9,156.00
筏 400	16"	420m/m	396m/m	11.2m/m	6M	1104.00	6624.00
A400	16"	420m/m	395m/m	11.8m/m	6M	1,157.50	6,945.00
W400	16"	420m/m	376m/m	20.5m/m	6M	1,974.00	11,844.00
筏 450	18"	470m/m	442m/m	13.1m/m	6M	1439.50	8637.00
A450	18"	470m/m	442m/m	13.2m/m	6M	1449.50	8697.00
B450	18"	470m/m	421m/m	22.9m/m	6M	2,470.00	14,820.00
A500	20"	520m/m	491m/m	15.0m/m	6M	1767.00	10603.80
B500	20"	520m/m	466m/m	25.3m/m	6M	3,022.00	18,132.00
A600	24"	630m/m	595m/m	18.0m/m	6M	2633.95	15803.70
B、W600	24"	630m/m	565m/m	30.7m/m	6M	4403.30	26421.00

衛生下水道(污水)工程專用

()%

標稱管徑		平均外徑	近似內徑	近似厚度	長 度	每米牌價	每支牌價
B40	1 1/2"	48m/m	40m/m	4.0m/m	4M	55.40	221.60
B50	2"	60m/m	51m/m	4.1m/m	4M	79.1	316.4
B65	2 1/2"	76m/m	67m/m	4.5m/m	4M	101.50	406.00
B80	3"	89m/m	78m/m	6.0m/m	5M	154.20	771.00
B80	3"	89m/m	78m/m	6.0m/m	4M	154.20	616.80
B100	4"	114m/m	100m/m	6.6m/m	5M	239.40	1197.00
B125	5"	140m/m	125m/m	7.0m/m	5M	314.30	1571.50
B150	6"	165m/m	146m/m	9.0m/m	5M	469.10	2345.50
B200	8"	216m/m	194m/m	10.5m/m	5M	709.10	3545.50
B250	10"	267m/m	240m/m	13m/m	5M	1084.30	5421.50
B300	12"	318m/m	286m/m	15.5m/m	5M	1537.90	7689.50
B350	14"	370m/m	333m/m	18.0m/m	6M	2136.40	12818.40
B400	16"	420m/m	378m/m	20.5m/m	6M	2763.60	16581.60
B450	18"	470m/m	423m/m	22.9m/m	6M	3458.00	20748.00
B500	20"	520m/m	466m/m	25.3m/m	6M	4230.80	25384.80
B600	24"	630m/m	567m/m	30.7m/m	6M	6164.90	36989.40
A40	1 1/2"	48m/m	44m/m	2.0m/m	4M	35.00	140.00
A50	2"	60m/m	56m/m	2.0m/m	4M	40.00	160.00
S65	2 1/2"	76m/m	72m/m	2.0m/m	4M	52.50	210.00
A80	3"	89m/m	83m/m	3.0m/m	4M	90.00	360.00
A90	3 1/2"	100m/m	94m/m	3.5m/m	4M	115.50	462.00
A100	4"	114m/m	107m/m	3.5m/m	4M	135.00	540.00
A125	5"	140m/m	131m/m	4.5m/m	5M	210.00	1050.00
A150	6"	165m/m	154m/m	5.5m/m	5M	300.00	1500.00
A200	8"	216m/m	202m/m	7.0m/m	5M	500.00	2500.00



150 磅可鍛鑄鐵零件牌告價格表

麥克 ()%
PRO ()%

名稱	簡稱	規 格									
		1/4~3/8	1/2"	3/4"	1"	1-1/4"	1-1/2"	2"	2-1/2"	3"	4"
彎頭	BL	23	14	23	36	59	73	118	187	280	561
異徑彎頭	BRL	26	17	26	40	63	80	124	231	329	638
45°彎頭	45°BL	26	17	26	40	63	80	124	231	329	627
90°內外牙彎頭	90°SL	26	17	26	40	63	86	139	249	364	
三通	BT	33	20	33	49	81	98	161	285	386	700
異徑三通	BRT		24	35	53	88	107	176	290	440	814
怪三通	RT					105	127	211	330		
內外牙三通	ST	34	34	50	68	110	146	215			
接頭	BS	18	13	18	27	43	56	86	135	191	333
異徑接頭	BRS	21	14	21	31	47	59	94	182	264	463
六角立布	HN	18	13	18	27	40	49	73	129	190	320
異徑六角立布	RHN		14	19	28	41	51	75			
管帽	CA	17	12	17	25	35	43	66	129	190	320
平座由任	UF	50	50	59	84	119	161	214	405	575	1104
銅座由任	Brcu		74	94	110	146	195	292	490	810	1403
錐形由任	Cu		61	78	90	123	165	245	414	690	1242
塞頭	P	12	9	12	18	24	35	59	112	170	302
十字通	Cr	51	36	51	70	110	142	195	380	485	855
異徑十字通	BRCr					116	169	225	423	560	
卜申	HBU	14	14	14	23	35	45	70	130	195	336
內外牙接頭	X(長)		16	21	31						
內外牙接頭	X(短)		14								
加長彎	XL		24								
45°內外牙彎頭	45°BMBE		27	40	57	85	119	187	390	534	
90°內外牙彎頭	90°BMBE	37	37	48	82	122	155	235	498	745	

300 磅牙件(熱浸鍍鋅)

	90 度彎頭	45 度彎頭	三通	十字通	接頭	塞頭	管帽	由任
								
1/2"	50	50	68	185	40	30	50	340
3/4"	75	75	110	230	63	40	63	420
1"	120	125	165	240	88	63	95	500
1 1/4"	200	180	300	350	163	75	125	650
1 1/2"	220	220	340	480	180	116	150	820
2"	350	375	590	650	275	200	250	900
2 1/2"	550	550	920	1250	500	375	380	1350
3"	915	915	1220	1575	640	565	630	1900
4"	1575	1575	2125	2850	1025	1010	1065	3260

	異徑90度彎頭	大小頭	異徑十字通	異徑三通					
				A B C		A B C			
				A	B	C	A	B	C
3/4" x 1/2"	75	63	230	3/4"x3/4"x1/2"		110	1 1/2" x 1" x 1 1/2"		340
1" x 1/2"	120	88	240	3/4"x3/4"x 1"		165	1 1/2" x 1 1/4" x 1/2"		340
1" x 3/4"	120	88	240	1" x 3/4"x3/4"		165	1 1/2" x 1 1/4" x 3/4"		340
1 1/4" x 1/2"	200	163	350	1" x 3/4"x1/2"		165	1 1/2" x 1 1/4" x 1"		340
1 1/4" x 3/4"	200	163	350	1" x 3/4"x 1"		165	1 1/2" x 1 1/4" x 2"		590
1 1/4" x 1"	200	163	350	1" x 1/2"x 1"		165	1 1/2" x 1 1/2" x 1/2"		340
1 1/2" x 3/4"	220	180	480	1" x 1" x 1/2"		165	1 1/2" x 1 1/2" x 3/4"		340
1 1/2" x 1/2"	220	180	480	1" x 1" x 3/4"		165	1 1/2" x 1 1/2" x 1"		340
1 1/2" x 1"	220	180	480	1" x 1" x 1 1/4"		300	1 1/2" x 1 1/2" x 1 1/4"		340
1 1/2" x 1 1/4"	220	180	480	1" x 1" x 1 1/2"		340	1 1/2" x 1 1/2" x 2"		590
2" x 3/4"	350	275	650	1 1/4" x 1" x 1/2"		300	2" x 1" x 2"		590
2" x 1"	350	275	650	1 1/4" x 1" x 3/4"		300	2" x 1 1/4" x 2"		590
2" x 1 1/4"	350	275	650	1 1/4" x 1" x 1"		300	2" x 1 1/2" x 1/2"		590
2" x 1 1/2"	350	275	650	1 1/4" x 1" x 1 1/4"		300	2" x 1 1/2" x 3/4"		590
2 1/2" x 2"	550	500	1250	1 1/4" x 1" x 1 1/2"		340	2" x 1 1/2" x 1"		590
備註：				1 1/4" x 1 1/4" x 1/2"		300	2" x 1 1/2" x 1 1/2"		590
1. 標準品：電鍍鋅，BSPT 牙				1 1/4" x 1 1/4" x 3/4"		300	2" x 1 1/2" x 2"		590
2. 材質：球狀石墨鑄鐵 ASTM A536				1 1/4" x 1 1/4" x 1"		300	2" x 2" x 1/2"		590
3. 外型尺寸：ASME/ANSI B16.3				1 1/4" x 1 1/4" x 1 1/2"		340	2" x 2" x 3/4"		590
4. 工作壓力：21kg/cm ² (300PSI)UL 及 FM 認證				1 1/4" x 1 1/4" x 2"		590	2" x 2" x 1"		590
				1 1/2" x 1" x 1/2"		340	2" x 2" x 1 1/4"		590
				1 1/2" x 1" x 3/4"		340	2" x 2" x 1 1/2"		590
				1 1/2" x 1" x 1"		340	2" x 2" x 2 1/2"		920

Victaulic 消防系統配管接頭另件

型號 品名 尺寸(外徑 mm)	005	009	75	001	003	12
	剛性接頭	剛性快拆接頭	撓性接頭	短徑 90 度彎頭	45 度彎頭	22.5 度彎頭
						
1"	-	-	485	-	-	-
1 1/4"	485	485	485	-	-	691
1 1/2"	485	485	485	-	-	726
2"	486	486	534	486	486	1220
2 1/2"(73)	559	559	632	730	730	1142
2 1/2"(76)	559	559	632	730	730	
3"	632	632	777	922	922	1732
4"	825	825	1019	1263	1263	1942
5"(139)	1214	-	1456	2386	2386	-
5"(141)	1214	-	1456	4611	4854	-
6"(165)	1408	1408	1652	2914	2914	-
6"(168)	1408	-	1652	2914	2914	4188
8"(216)	2914	-	3156	-	-	-
8"(219)	2914	-	3156	6069	6069	7927

型號 品名 尺寸(外徑 mm)	002	35	741(ANSI 25/150)	741(10K)	006
	短徑三通	十字通	法蘭轉換接頭	法蘭轉換接頭	盲板
					
1 1/4"	-	-	-	-	137
1 1/2"	-	-	-	-	137
2"	656	-	2361	-	268
2 1/2"(73)	971	2497	3409	-	413
2 1/2"(76)	971	-	3409	-	-
3"	1214	3495	3540	3540	437
4"	2137	9638	3672	3672	656
5"(139)	3365	-	-	-	-
5"(141)	-	-	4720	-	1214
6"(165)	4614	12487	5245	5245	-
6"(168)	4614	12487	5245	5245	1408
8"(219)	9227	83995	6556	5858	3883
10"	-	170537	11801	-	-
12"	-	223075	15734	-	-
14"	-	-	31469	-	-
16"	-	208287	38813	-	-

Victaulic 消防/空調系統配管接頭另件

	型號	920N (BSPT)	920 G		型號	920N (BSPT)	920 G
	品名	鞍座(內牙)	鞍座(溝槽)		品名	鞍座(內牙)	鞍座(溝槽)
尺寸(外徑 mm)				尺寸(外徑 mm)			
2"X1/2"	1708	-	5" (141)X1 1/2"	3398	4001		
2"X3/4"	1708	-	5" (141)X2"	3398	4001		
2"X1"	1733	-	6"(165)X1 1/4"	1534	-		
2"X1 1/4"	1198	2859	6"(165)X1 1/2"	1601	-		
2"X1 1/2"	1198	2859	6"(165)X2"	1708	-		
2 1/2"(73)X1/2"	1769		6"(165)X2 1/2"(76)	2773	2732		
2 1/2"(73)X3/4"	1769		6"(165)X3"	2366	-		
2 1/2"(73)X1"	1800		6"(165)X4"	4475	3603		
2 1/2"(73)X1 1/4"	1336	2859	6"(168)X1 1/2"	2671	3364		
2 1/2"(73)X1 1/2"	1336	2859	6" (168)X2"	2671	3364		
2 1/2"(76)X1/2"	1254	-	6" (168)X2 1/2"(73)	2671	4220		
2 1/2"(76)X3/4"	1254	-	6" (168)X3"	4287	4582		
2 1/2"(76)X1"	1254	-	6" (168)X4"	5861	5734		
2 1/2"(76)X1 1/4"	1336	-	8"X2"	4614	-		
2 1/2"(76)X1 1/2"	1336	-	8"X2 1/2"	5545	5504		
3"X1/2"	2182	-	8"X3"	6702	6865		
3"X3/4"	1877	-	8"X4"	7513	7726		
3"X1"	1839	-					
3"X1 1/4"	1603	-	型號 品名 尺寸(外徑 mm)	920N(BSPT) 十字鞍座(內牙)	920 G 十字鞍座(槽)		
3"X1 1/2"	1603	2859					
3"X2"	1603	2859					
4"X1/2"	1941	-					
4"X3/4"	1941	-					
4"X1"	1927	-					
4X1 1/4"	1700	2650				2 1/2"(76.1)*1"	2170
4"X1 1/2"	1700	2951	2 1/2"(76.1)*1 1/2"	1870			
4"X2"	1700	3303	2 1/2"(76.1)*1 1/4"	1728			
4"X2 1/2"(73)	2428	2875	3"*3"*1 1/4"*1 1/4"	1941			
4"X2 1/2"(76)	2428	1895	3"*3"*1 1/2"*1 1/2"	1831			
4"X3"	3089	3088	3"*3"*2"*2"	2208	4556		
5"(141)X2 1/2"(73)	3398	4001	4"*4"*1"*1"	3052			
5"(141)X3"	4425	4730	4"*4"*1 1/4"*1 1/4"	1763			
5"(139)X2"	4739	-	4"*4"*1 1/2"*1 1/2"	1815			
			4"*4"*2"*2"	2068	5784		
			4"*2 1/2"(76.1)	3425	3425		

Victaulic 消防/空調系統配管接頭另件

尺寸(外徑 mm)	型號 品名	25	50	尺寸(外徑 mm)	型號 品名	25	50
		異徑三通	大小頭			異徑三通	大小頭
							
1 1/2" * 1"	-	-	334	6"(168) * 6"(168) * 2"	-	7867	2622
2" * 2" * 3/4"	-	-	-	6"(168) * 6"(168) * 2 1/2"(73)	-	7867	2622
2" * 2" * 1"	-	-	976	6"(168) * 6"(168) * 3"	-	7081	2622
2" * 1 1/4"	-	-	1033	6"(168) * 6"(168) * 4"	-	7081	2622
2" * 2" * 1 1/2"	-	-	1159	6"(168) * 6"(168) * 5"(141)	-	7081	2622
2 1/2"(73) * 2 1/2"(73) * 1"	-	-	-	8"(216) * 8"(216) * 3"(89)	-	33699	4247
2 1/2"(73) * 2 1/2"(73) * 1 1/2"	1626	-	-	8"(216) * 8"(216) * 4"(114)	-	33699	4441
2 1/2"(73) * 2 1/2"(73) * 2"	1626	-	892	8"(216) * 8"(216) * 5"(139)	-	33699	3494
2 1/2"(76) * 2 1/2"(76) * 2"	894	-	320	8"(216) * 8"(216) * 6"(165)	-	15269	3850
3" * 3" * 1"	-	-	-	8"(219) * 8"(219) * 2"	-	-	-
3" * 3" * 1 1/2"	-	-	-	8"(219) * 8"(219) * 2 1/2"	-	-	-
3" * 3" * 2"	2387	-	944	8"(219) * 8"(219) * 3"	-	-	8563
3" * 3" * 2 1/2"(73)	2622	-	944	8"(219) * 8"(219) * 4"	-	12062	3934
3" * 3" * 2 1/2"(76)	1537	-	389	8"(219) * 8"(219) * 5"(141)	-	-	3934
4" * 4" * 1"	-	-	-	8"(219) * 8"(219) * 6"(165)	-	-	3934
4" * 4" * 1 1/2"	-	-	-	8"(219) * 8"(219) * 6"(168)	-	12062	3934
4" * 4" * 2"	3146	-	1444	10"(267) * 10"(267) * 3"(89)	-	56819	-
4" * 4" * 2 1/2"(73)	3146	-	1444	10"(267) * 10"(267) * 4"(114)	-	55479	15442
4" * 4" * 2 1/2"(76)	1881	-	846	10"(267) * 10"(267) * 5"(139)	-	56819	12567
4" * 4" * 3"	3146	-	1444	10"(267) * 10"(267) * 6"(165)	-	23411	12567
5"(139) * 5"(139) * 2"	4337	-	-	10"(267) * 10"(267) * 8"(216)	-	26680	6368
5"(139) * 5"(139) * 2 1/2"(76)"	2895	-	1444	10"(273) * 10"(273) * 2"	-	-	-
5"(139) * 5"(139) * 3"(89)	2960	-	1444	10"(273) * 10"(273) * 3"	-	35272	-
5"(139) * 5"(139) * 4"(114)	3012	-	1444	10"(273) * 10"(273) * 4"	-	37239	10489
5"(141) * 5"(141) * 2"	-	-	-	10"(273) * 10"(273) * 5"	-	37239	-
5"(141) * 5"(141) * 2 1/2"(73)	-	-	-	10"(273) * 10"(273) * 6"(165)	-	37239	-
5"(141) * 5"(141) * 3"	6032	-	2884	10"(273) * 10"(273) * 6"(168)	-	37239	10489
5"(141) * 5"(141) * 4"	6032	-	2884	10"(273) * 10"(273) * 8"	-	37239	10489
6"(165) * 6"(165) * 2"	7036	-	2188	12"(318) * 12"(318) * 3"(89)	-	86282	-
6"(165) * 6"(165) * 2 1/2"(76)	4302	-	2188	12"(318) * 12"(318) * 4"(114)	-	86282	-
6"(165) * 6"(165) * 3"	4302	-	1289	12"(318) * 12"(318) * 5"(139)	-	86282	-
6"(165) * 6"(165) * 4"	4302	-	1289	12"(318) * 12"(318) * 6"(165)	-	86282	23332
6"(165) * 6"(165) * 5"(139)	4302	-	1289	12"(318) * 12"(318) * 8"(216)	-	86282	23332

Victaulic 消防/空調系統配管接頭另件

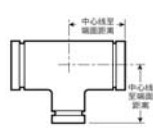
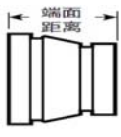
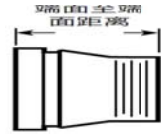
尺寸(外徑 mm)	型號 品名	25	50	尺寸(外徑 mm)	型號 品名	52
	異徑三通	大小頭	大小頭(外牙)			
						
12"(318)*12"(318)*10"(267)		36225	8389	2"*3/4"		4090
12"(323)*12"(323)*3"		52449	-	2"*1"		2407
12"(323)*12"(323)*4"		52449	-	2"*11/4"		3161
12"(323)*12"(323)*5"(141)		52449	-	2"*11/2"		2569
12"(323)*12"(323)*6"(168)		52448	13112	21/2"(73)*11/4"		2562
12"(323)*12"(323)*8"(219)		52448	13112	21/2"(73)*11/2"		2747
12"(323)*12"(323)*10"(273)		52448	13112	21/2"(73)*2"		2741
14"*14"*8"		-	20318	21/2"(76)*2"(60)		771
14"*14"*10"		-	22473	3"*1"		2800
14"*14"*12"		-	22781	3"*11/2"		2895
16"*16"*8"		-	27091	3"*2"		771
16"*16"*10"		-	26168	3"*21/2"(76)		771
16"*16"*12"		-	28015	4"*1"		4749
18"*18"*10"		-	31401	4"*2"		1363
18"*18"*12"		-	34480	4"*21/2"		3705
18"*18"*14"		-	34172	4"*21/2"(76)		1290
18"*18"*16"		-	35403	4"*3"		1290
20"*20"*6"		-	-	5"(139)*21/2"(76)		1800
20"*20"*8"		-	-	5"(139)*3"(88)		1800
20"*20"*10"		106568	-	6"(165)*3"(88)		1800
20"*20"*12"		112764	45409	6"(168)*1"		6810
20"*20"*14"		107807	46271	6"(168)*2"		5326
20"*20"*16"		112764	49257	6"(168)*21/2"(73)		5159
20"*20"*18"		112145	-	6"(168)*3"		6612
24"*24"*6"		157374	-			
24"*24"*8"		157374	-			
24"*24"*10"		157994	-			
24"*24"*12"		162331	-			
24"*24"*14"		-	-			
24"*24"*16"		162951	-			
24"*24"*18"		-	64034			
24"*24"*20"		161401	-			

Victaulic 空調/標準型系統配管接頭另件

型號 品名	07	77	10	11	12	20
	剛性街頭	撓性街頭	短徑 90 度彎頭	45 度彎頭	22.5 度彎頭	短徑三通
尺寸(外徑 mm)						
3/4"	-	734	-	-	-	-
1"	852	734	919	917	-	1422
1 1/4"	852	734	919	917	691	1493
1 1/2"	852	734	919	917	726	1374
2"	892	892	920	917	1220	1311
2 1/2"(73)	944	944	1048	1048	1142	1653
2 1/2"(76)	944	944	1048	1048	-	1653
3"	1048	1181	1259	1259	1732	2361
4"	1469	1836	1887	1887	1942	3146
5"(139)	1823	2884	2549	2301	-	3705
5"(141)	1836	2884	3934	3934	-	6432
6"(165)	2361	3409	4458	4458	-	7081
6"(168)	2361	3409	4458	4458	4188	7081
8"(216)	4196	5507	8655	8655	-	13637
8"(219)	4196	5507	8655	8655	7927	13637
10"(267)	6032	7604	15472	15472	-	27012
10"(273)	6032	7604	15472	15472	-	27012
12"(318)	7604	9440	23077	23077	-	37239
12"(323)	7604	9440	23077	23077	-	37239
14"	-	17045	36189	36189	-	65037
16"	-	20717	45106	45106	-	73427
18"	-	23601	83918	83918	-	112764
20"	-	33042	104898	104898	-	144234
22"	-	27379	-	-	-	-
24"	-	44581	138989	138989	-	173081

Victaulic 空調/標準型系統配管接頭另件

型號 品名	60	107	177	743(ANSI 300)
	盲板	剛性快拆接頭	撓性快拆接頭	法蘭轉換接頭
尺寸(外徑 mm)				
1"	334	-	-	-
1 1/4"	461	-	-	-
1 1/2"	476	-	-	-
2"	525	758	769	6231
2 1/2"(73)	552	863	931	7239
2 1/2"(76)	552	837	931	-
3"	709	1124	1120	9902
4"	920	1443	1795	13208
5"(139)	1415	1990	1673	-
5"(141)	-	1746	1860	15003
6"(165)	1574	2332	3163	-
6"(168)	1574	2366	3163	17467
8"(216)	3251	3943	4900	-
8"(219)	4733	3943	4900	20049
10"	7867	6743	-	31954
12"	11801	8935	-	34147

Victaulic 不銹鋼系統配管接頭另件

型號 品名	489	475	410 SS	411 SS	420 SS	460 SS
	剛性接頭	撓性接頭	90 度彎頭	45 度彎頭	三通	盲板
尺寸(外徑 mm)						
3/4"	-	-	-	-	-	305
1"	-	-	1500	1196	-	429
1 1/4"	-	-	2118	1561	-	667
1 1/2"	-	-	2942	2097	4576	985
2"	2747	2820	3862	2668	6493	1521
2 1/2"(73)	-	-	7256	4984	8192	2259
2 1/2"(76)	3321	3578	6277	4567	10577	3067
3"	4405	5028	5188	3632	10343	3019
4"	6848	7112	8997	6297	15264	4458
5"(139)	8809	9078	15567	10900	26225	8460
6"(165)	10556	11865	20844	14592	36165	9715
6"(168)	-	-	20844	14592	36165	9715
8"(216)	45517	-	42383	29668	62248	16372
8"(219)	-	-	42383	29668	62248	16372
10"(267)	60321	-	74146	51904	131526	-
10"(273)	-	-	74146	51904	131526	40702
12"(318)	73421	-	108938	76255	179208	-
12"(323)	-	-	108938	76255	179208	60918

Victaulic 不銹鋼系統配管接頭另件

型號 品名	425 SS	450 SS	型號 品名	425 SS	450 SS
	異徑三通	同心異徑接頭		異徑三通	同心異徑接頭
尺寸(外徑 mm)			尺寸(外徑 mm)		
2"X1 1/2"		2416	6"(168)X3"	36686	10750
2 1/2"(73)X2"	7739	3862	6"(168)X4"	34936	9774
2 1/2"(76)X2"	10124	2205	8"(216)X4"	68628	15985
3"X2"	11405	3151	8"(216)X6"(165)	65356	13900
3"X2 1/2"(76)	10864	3005	8"(219)X4"	68628	15985
3"X2 1/2"(73)	10864	3005	8"(219)X6"(168)	65356	13900
4"X2"	17667	4733	10"(267)X6"(165)	244779	29403
4"X2 1/2"(73)	16828	4508	10"(267)X8"(216)	215084	27741
4"X2 1/2"(76)	16828	4508	10"(273)X6"(168)	145010	29403
4"X3"	16028	4294	10"(273)X8"(219)	127050	27741
5"(139)X3"	28912	8362	12"(318)X8"(216)	335120	41517
5"(139)X4"	27535	7470	12"(318)X10"(267)	294282	39541
6"(165)X3"	39876	10750	12"(323)X8"(219)	197575	41517
6"(165)X4"	37975	9774	12"(323)X10"(273)	173116	39541
6"(165)X5"(139)	55571	20689			

滾溝法蘭接頭

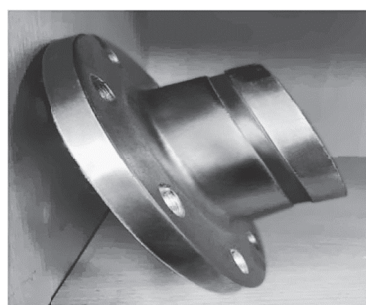

規 格	牌價
ST 304 法蘭 10K 滾溝機械接頭 2"	4370
ST 304 法蘭 10K 滾溝機械接頭 2-1/2"	5650
ST 304 法蘭 10K 滾溝機械接頭 3"	6660
ST 304 法蘭 10K 滾溝機械接頭 4"	8700
ST 304 法蘭 10K 滾溝機械接頭 5"	11640
ST 304 法蘭 10K 滾溝機械接頭 6"	16520
ST 304 法蘭 10K 滾溝機械接頭 8"	19720

規 格	牌 價
鍍鋅法蘭 10K 滾溝機械接頭 2"	1410
鍍鋅法蘭 10K 滾溝機械接頭 2-1/2"	1770
鍍鋅法蘭 10K 滾溝機械接頭 3"	2090
鍍鋅法蘭 10K 滾溝機械接頭 4"	2645
鍍鋅法蘭 10K 滾溝機械接頭 5"	3490
鍍鋅法蘭 10K 滾溝機械接頭 6"	4567
鍍鋅法蘭 10K 滾溝機械接頭 8"	5785

規 格	牌價
鍍鋅法蘭 20K 滾溝機械接頭 2"	1476
鍍鋅法蘭 20K 滾溝機械接頭 2-1/2"	1935
鍍鋅法蘭 20K 滾溝機械接頭 3"	2857
鍍鋅法蘭 20K 滾溝機械接頭 4"	3434
鍍鋅法蘭 20K 滾溝機械接頭 5"	4827
鍍鋅法蘭 20K 滾溝機械接頭 6"	8260
鍍鋅法蘭 20K 滾溝機械接頭 8"	8260

規 格	牌 價
鍍鋅法蘭 10K 滾溝機械接頭 SCH40 2"	1540
鍍鋅法蘭 10K 滾溝機械接頭 SCH40 2-1/2"	1753
鍍鋅法蘭 10K 滾溝機械接頭 SCH40 3"	2074
鍍鋅法蘭 10K 滾溝機械接頭 SCH40 4"	2790
鍍鋅法蘭 10K 滾溝機械接頭 SCH40 5"	3840
鍍鋅法蘭 10K 滾溝機械接頭 SCH40 6"	4700
鍍鋅法蘭 10K 滾溝機械接頭 SCH40 8"	7520



原創發明

溝槽接口管道連接，亦即如今的“溝槽”概念，誕生於1925年。當時，唯特利推出了首個機械管道連接方案，成功使用機械接頭和溝槽管道接口連接管道系統。同業將此發明稱為“唯特利接頭”。



victory + hydraulic = **victaulic**

如今，世界各地的管道應用中幾乎都有唯特利溝槽機械系統的身影。

雖然溝槽概念已成為便捷安裝的代名詞，但並非所有溝槽產品的製造商都相同。

唯特利只有一個。

WWW.VICTAULIC.COM

VICTAULIC

溝槽管道連接技術

工作原理

溝槽經冷鍛製成，或在管道接口處進行車槽加工。

由接頭外殼罩著的密封墊圈包在兩個溝槽管口四周，接頭外殼的鍵部分與溝槽咬合。

螺桿和螺帽使用套筒扳手或衝擊扳手旋緊。

溝槽接頭類型

- 撓性接頭 – 允許在可控範圍內發生線性延伸和角度偏移，因而可承受管道偏轉以及熱膨脹與收縮。
- 剛性接頭 – 不允許偏移，類似於法蘭連接或焊接接頭。

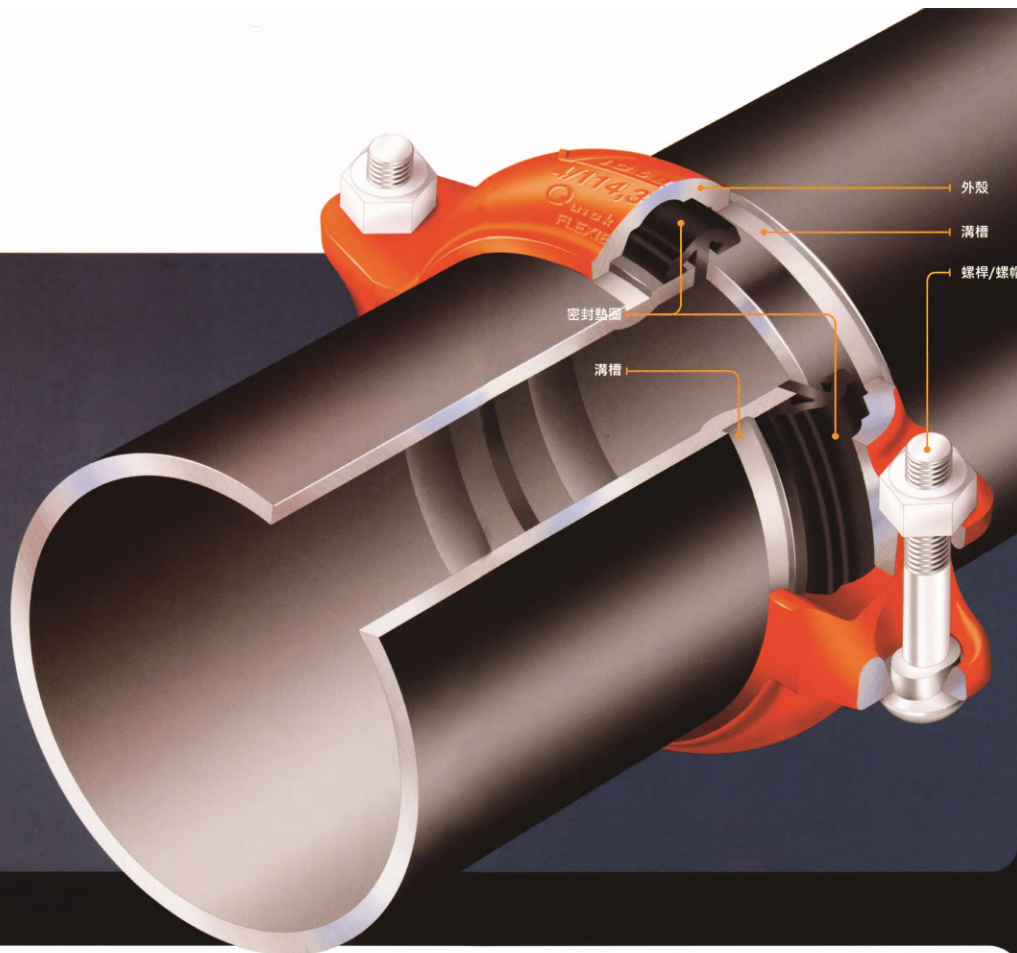

你的設計優勢來自於我們的產品特色

撓性
可預測和控制管道熱偏移。

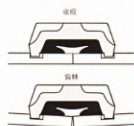

噪音與振動衰減
減少了整個管道系統的噪音與振動傳遞。

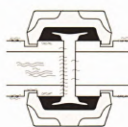

地震應力的吸收
具備顯著的壓力限制和管末負載能力，能夠承受因地震力造成的管道偏移。

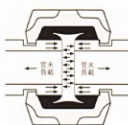

系統維護與擴展
每個連接處都有接頭，便於進行維護和系統擴展。

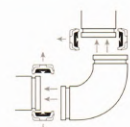

方便校準
溝槽接頭可朝向任意方向，即便在狹窄空間安裝亦無需擔心。

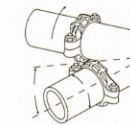

VICTAULIC

供暖和冷卻系統

透過選用並安裝唯特利系統，工程師、業主和安裝承包商可從以下幾方面節省工時和成本：

- 縮短施工期
- 降低總安裝成本
- 加強工作環境安全
- 減少系統停機率



AGS®

WWW.VICTAULIC.COM/HVAC

供暖

適用於 $\frac{3}{4}$ - 60" / 20 - 1525 mm規格供暖系統的完整產品系列。

應用

- 熱水(循環)供暖
- 乙二醇系統
- 鍋爐管道系統
- 雙溫系統
- 水源熱泵
- 周邊供暖/翅片管
- 風機盤管
- 盤管式加熱器
- 帶熱水盤管的變風量箱
- 被動式或主動式太陽能系統



產品適用於：
碳鋼管
鍍鋅管

冷卻

適用於 $\frac{3}{4}$ - 60" / 20 - 1525 mm規格冷卻系統的完整產品系列。

應用

- 冷卻水
- 冷凝水
- 乙二醇系統
- 冷卻塔
- 鹽水系統
- 特殊冷卻系統
- 中央冷卻器
- 冰水機系統
- 空調



唯特利溝槽系統

- 與焊接相比，工時平均減少45%
- 避免了消防巡邏的昂貴成本以及危險的煙霧和明火
- 材料處理量減少30 - 70%
- 減少了能源消耗



VICTAULIC

水管系統

由於承包商無需進行銅焊或錫焊，因而減少了返工風險。

唯特利系統也是市場上最快速的連接方法，安裝速度是焊接、銅焊或錫焊的幾乎兩倍，比壓接產品快20%。

WWW.VICTAULIC.COM/PLUMBING

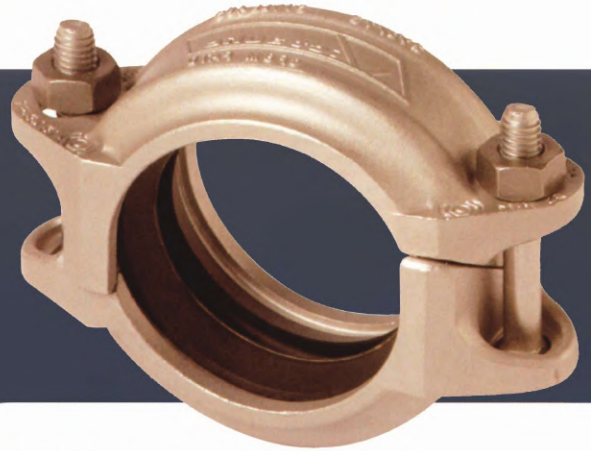

管道工程

適用於 $\frac{1}{2}$ - 60" / 15 - 1525 mm規格水管系統的完整產品系列。

應用

- 冷卻水系統
- 雨水系統
- 屋頂排水
- 真空水管系統
- 排水、廢棄物和通風系統

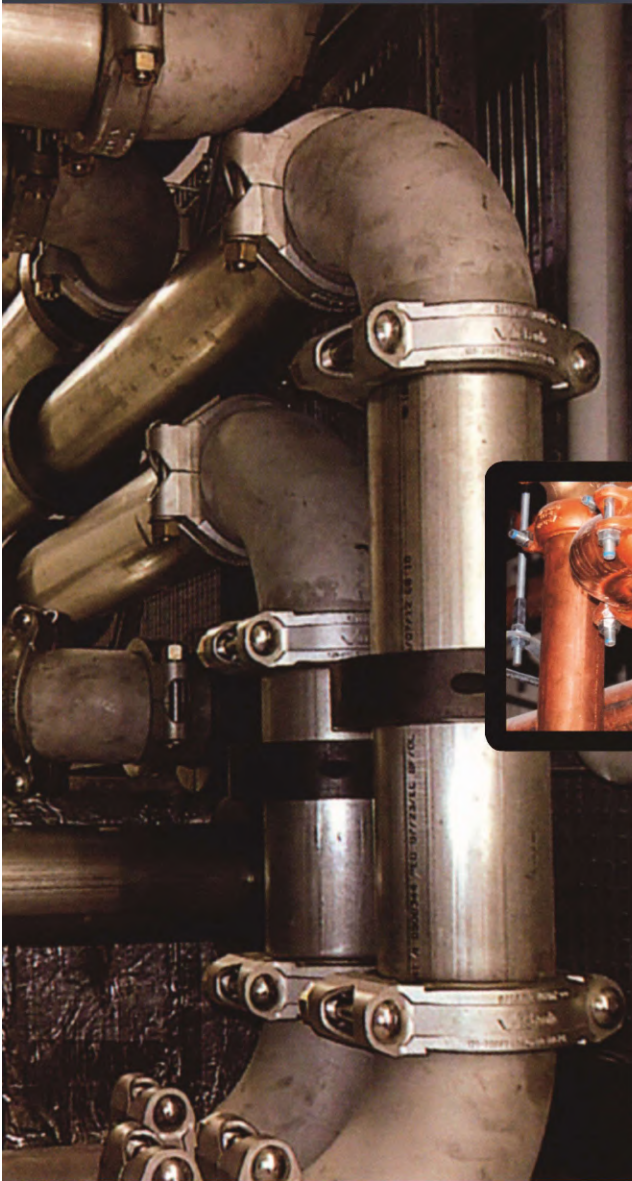

產品適用於：
銅管
不銹管
鍍鋅管

VICTAULIC

消防系統

唯特利提供專為消防系統設計的完整創新產品系列。

WWW.VICTAULIC.COM/FP



消防

適用於 ½ - 8" / 15 - 200 mm 規格消防系統的完整產品系列。

產品系列包括

- 設備、閥門、接頭、管件、撓性撒水頭配件、開孔產品和全套自動撒水頭
- 適用於濕式和乾式管道系統的完整系統解決方案
- 管道製備工具和附件



產品適用於：
破鋼管

VICTAULIC

系統解決方案

滿足並超越緊迫的工程進度

標準溝槽接頭的安裝速度比焊接快5倍，比法蘭連接快3倍。而唯特利接頭採用快速安裝使用技術，其安裝速度只有標準溝槽接頭的一半。

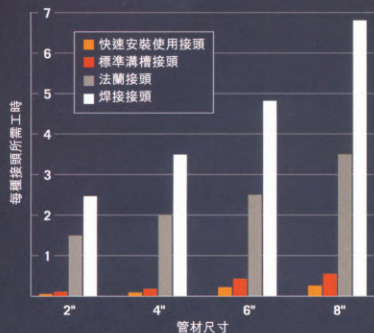

WWW.VICTAULIC.COM/SCHEDULE

加強安全並減少風險。

選用唯特利產品無需進行明火作業，因此可減少工程師在設計階段的風險，而且降低了業主的潛在責任和損失。消除明火作業可減少客戶、居住者和承包商的風險。

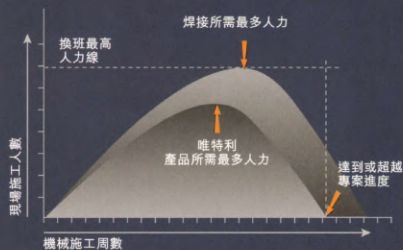

WWW.VICTAULIC.COM/SAFETY

由唯特利專業製造，旨在減少風險並滿足最終用戶的需求。

- 唯特利開發彈性體配方，設計密封墊圈/密封件幾何結構，並製造自己的密封墊圈。
- 唯特利自行生產所有樣品。
- 唯特利對工廠生產的每個產品均執行冶金試驗。
- 除了運用自己的工程技術和嚴格要求以外，唯特利還採用產品測試標準和同行規範。
- 唯特利實施垂直整合，支援持續的工藝改良和一致的全球製造。
- 唯特利採用最先進的分析設備。
- 唯特利倚賴的是近一個世紀之久的產品開發和製造歷史資料。

世界上只有一家管道產品製造商敢於承諾以品質帶來這些價值，它就是唯特利。



創造一個更可持續的環境。

唯特利產品.....

- 90%均採用再生材料和精實製造工藝生產。
- 便於對系統進行定期維護和不定期維護，因此能夠保持建築物系統的最佳運作效率。
- 安裝後能夠在建築物內長期使用，並可回收和重新使用。
- 消除了危險的明火並可減少能源消耗。

SUSTAINABLEPIPPINGSOLUTIONS.COM



VICTAULIC

系統解決方案

致力滿足真實需求

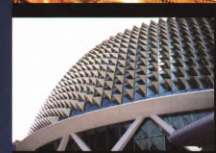
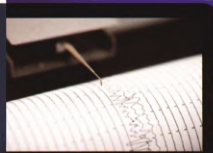

允許管道偏移，對組件的壓力更小

唯特利接頭鍵的尺寸比管道溝槽窄，因此接頭鍵可在溝槽內移動，而且能夠保證密封墊圈的承壓密封性能。

此外，接頭外殼的寬度允許管端有間隙，因此能夠在可控範圍內發生線性延伸和角度偏移。

機械接頭保持自我約束連接，獨特的壓力反應設計即便在出現偏轉和管道偏移時，也能提供密封性能。

唯特利接頭透過以下四種方式承受管道熱偏移：

- 提供採用溝槽機械管道組件的膨脹節
- 允許系統“自由浮動”
- 利用撓性溝槽接頭的線性延伸或偏轉能力
- 提供採用溝槽機械組件的膨脹環

WWW.VICTAULIC.COM/THERMAL

保持管道系統在發生地震時運作完好。

在美國賓州伯利恆裡海大學大型結構系統先進技術中心的實時多向實驗室執行的試驗證明，唯特利溝槽機械接頭具備適用性，在發生地震時可保持管道系統運作完好。

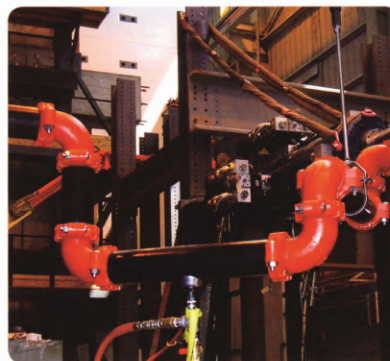

WWW.VICTAULIC.COM/SEISMIC

抑制80-90%的總體振動強度。

總部位於西雅圖的SSA Acoustics LLP經過現場測量後得出以下結論，當將三個接頭靠近振動源相互連結排列時，唯特利機械管道系統表現出無與倫比的隔振和消聲特性。

三個（3）唯特利 77 型撓性接頭提供的額外衰減百分比*

*10-100Hz頻率範圍的平均值

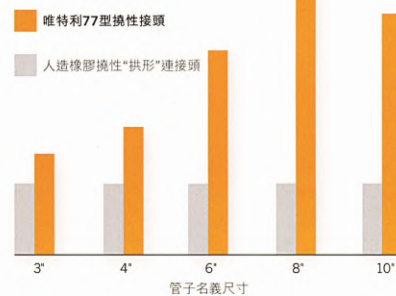

WWW.VICTAULIC.COM/NOISEANDVIBRATION

VICTAULIC

你的全面專案交付合作夥伴

降低對工期和獲利造成的風險

從設計直到施工階段，唯特利都將與貴司密切合作，確保工程效率達到最大。



唯特利製造室



三維建模

為施工設計

預測

三維建模·適用於多個平臺 (Revit, MEP等)

BIM協調套件有助於減少工時、施工天數和額外成本。

產品規格與選擇服務

價值工程·例如系統偏移承受力、減振能力、系統靈活性、校準便利性等等。

精實施工

精實預加工概念可消除瓶頸，從而提高產量。

- 精實製造概念可應用於加工廠和現場

- 精實加工廠評估

- 唯特利製造室

虛擬裝車軟體可進行觸控式加工·專利申請中

全面供應鏈

更安全的系統安裝意味著工時更少·成本更低·風險更小。

箱包和標籤服務可最大範圍的減少材料處理量。

協調送貨可將產品在指定時間交付至指定地點。

培訓與繼續教育機會

檢驗服務保證管道安裝後可持續在系統生命週期內使用。

提供範圍全面的產品

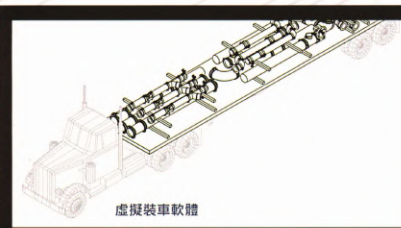

虛擬裝車軟體





唯特利灑水軟管/符合FM. 消防署認證通過

Price List 2017 - Victaulic Vicflex sprinkler

Effective date: May. 12, 2017

包網軟管
AH3 Braided Flexible Hose
產品型錄請參閱10.94



規格	每件約重	本體單價
公稱管徑	單位:KG	NT\$
31"X1/2"	1.09	1,065
31"X3/4"	1.09	1,065
36"X1/2"	1.18	1,124
36"X3/4"	1.18	1,124
48"X1/2"	1.40	1,303
48"X3/4"	1.40	1,303
60"X1/2"	1.64	1,543
60"X3/4"	1.64	1,543
72"X1/2"	1.86	1,842
72"X3/4"	1.86	1,842

可調式支架
AB7 Adjustable Bracket

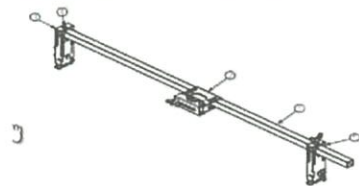

規格	每件約重	本體單價
公稱管徑	單位:KG	NT\$
700MM	0.6	494
1400MM	0.8	657

固定式支架
AB7 Bracket

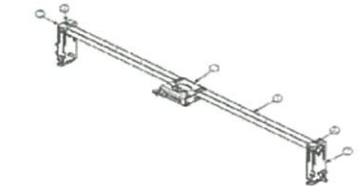

規格	每件約重	本體單價
公稱管徑	單位:KG	NT\$
24"	0.6	415
48"	0.8	POA

AB2 支架

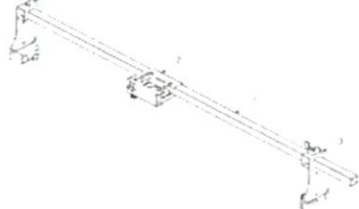

規格	單價
公稱管徑	NT\$
24"	648
48"	868

Price List 2017 - Victaulic Vicflex sprinkler

Effective date: May. 12, 2017

直式大小頭-NPT 5.5"
Straight Reducer-5.5"

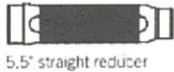

5.5" straight reducer

規格	每件的重	本體單價
公稱管徑	單位:KG	NT\$
5.5"-1/2 NPT	0.4	360
5.5"-3/4 NPT	0.4	360
1" Nipple	0.5	124

90度彎大小頭-短
90 Elbow Reducer-Short



Short 90° elbow reducer

規格	每件的重	本體單價
公稱管徑	單位:KG	NT\$
4"-1/2"	0.5	708
4"-3/4"	0.5	708

90度彎大小頭-長
90 Elbow Reducer-Long



Long 90° elbow reducer



規格	每件的重	本體單價
公稱管徑	單位:KG	NT\$
6"-1/2"	0.5	708
6"-3/4"	0.5	708

VicFlex™ 撒水頭管件系統

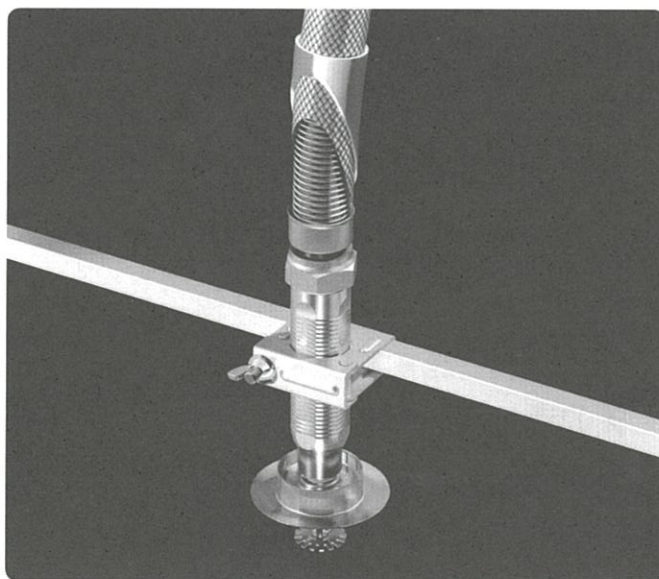
Victaulic® (唯特利™) 提供全系列的VicFlex 撒水頭管件系統，完全由Victaulic (唯特利) 設計與製造，實現統一的安裝和一致的性能。VicFlex撒水頭管件系統乃信心之選，提供100%抗扭結和市場上最緊湊的彎曲度。安裝VicFlex比螺紋黑管可快10倍，避免了雜亂的切割工具和定制懸臂預製。VicFlex系統特有的支架、軟管和管件，可適用於各種撒水頭系統應用，包括商業吊頂、商業金屬或木龍骨硬頂/幹牆天花板、磚牆間隔、潔淨室環境或工業除塵系統。



軟管

-  VicFlex編織軟管 (AH2系列)
-  VicFlex編織高壓軟管 (AH2-300系列)
-  VicFlex編織軟管 (AH1系列)
-  VicFlex編織軟管 (AH4系列)
-  VicFlex波紋軟管 (AH5系列)

支架 (商業天花板)

-  VicFlex支架 (AB1型)
-  VicFlex支架 (AB2型)
-  VicFlex支架 (AB7型)
-  VicFlex支架 (AB7可調型)
-  VicFlex支架 (AB4型)
-  VicFlex支架 (AB9型)
-  VicFlex支架 (AB8型)
-  VicFlex支架 (AB10型)

支架 (特製系統)

-  VicFlex, 用於表面安裝 (AB3型)
-  VicFlex, 用於冷庫 (AB6型)
-  VicFlex, 用於傳輸管道 (AQD系列)
-  VicFlex, 用於潔淨室 (AQC系列)

附件

-  VicFlex異徑管短節和彎頭



認證/列名:

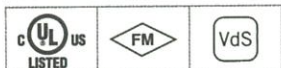

VicFlex™ 編織軟管

AH2系列

如需完整資訊，請下載10.85號技術檔

- 可提供最緊湊的彎曲度；100%由Victaulic® (唯特利™) 設計與製造
- 比螺紋黑管可快10倍，100%抗扭結
- 最小彎曲半徑：cULus - 2英寸 | 51毫米，FM - 7英寸 | 178毫米，VdS - 3英寸 | 76.3毫米
- 尺寸 31 - 72英寸 | 790 - 1830毫米
- 壓力可達232psi | 1600kPa | 16巴



認證/列名:



VicFlex™ 編織高壓軟管

AH2-300系列

如需完整資訊，請下載10.84號技術檔

- 高壓軟管；100%由Victaulic (唯特利) 設計與製造
- 比螺紋黑管可快10倍，100%抗扭結
- 最小彎曲半徑：FM - 7英寸 | 178毫米
- 尺寸 31 - 72英寸 | 790 - 1830毫米
- 壓力可達300psi | 2068 kPa | 21巴



認證/列名:

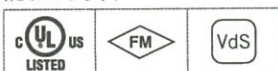

VicFlex™ 編織軟管

AH1系列

如需完整資訊，請下載10.85號技術檔

- 撓性不銹鋼軟管，用於吊頂或保護層的天花板
- 比螺紋黑管可快10倍，100%抗扭結
- 最小彎曲半徑：cULus - 3英寸 | 76毫米，FM - 7英寸 | 178毫米，VdS - 3英寸 | 76毫米
- 尺寸 31 - 72英寸 | 790 - 1830毫米
- 壓力可達232psi | 1600kPa | 16巴

熱浸鍍鋅鐵立布(20S)

CNS6445(與鋼管同材質厚度)

規格 長度	1/4"	3/8"	1/2"	3/4"	1"	1 1/4"	1 1/2"	2"	2 1/2"	3"	4"	5"	6"
1呎(3cm)	13	13	10	13	20	25	35	45	-	-	-	-	-
5cm	15	15	10	12	20	28	36	44	70	90		-	-
2呎(6cm)	17	17	14	17	25	35	40	60	80	105	160	-	-
7cm	15	15	12	15	24	43	45	56	75	95	147	-	-
3呎(9cm)	20	20	17	20	35	50	55	70	100	135	160	-	-
10cm	18	18	15	18	30	46	55	70	105	154	160	-	-
4呎(12cm)	25	25	22	25	40	60	70	80	125	160	200	-	-
5呎(15cm)	32	32	27	32	50	70	85	100	150	185	240	420	460
6呎(18cm)	37	37	31	37	60	80	95	115	175	215	280	480	540
7呎(20cm)	42	42	36	42	65	90	115	130	200	245	320	580	620
8呎(25cm)	47	47	41	47	75	100	130	145	225	275	360	660	720
9呎(27cm)	52	52	45	52	85	115	145	165	250	310	400	780	850
10呎(30cm)	60	60	50	60	90	130	160	190	280	350	450	850	1000

※長度可另依需求訂製

熱浸鍍鋅鐵立布(40S)

CNS4626/A53(與鋼管同材質厚度)

規格 長度	1/4"	3/8"	1/2"	3/4"	1"	1 1/4"	1 1/2"	2"	2 1/2"	3"	4"	5"	6"
1呎(3cm)	26	26	20	26	40	50	70	90	-	-	-	-	-
5cm	30	30	20	24	40	56	72	88	140	180		-	-
2呎(6cm)	34	34	28	34	50	70	80	120	160	210	320	-	-
7cm	30	30	24	30	48	86	90	112	150	190	294	-	-
3呎(9cm)	40	40	34	40	70	100	110	140	200	270	320	-	-
10cm	36	36	30	36	60	92	110	140	210	308	380	-	-
4呎(12cm)	50	50	44	50	80	120	140	160	250	320	400	-	-
5呎(15cm)	64	64	54	64	100	140	170	200	300	370	480	840	920
6呎(18cm)	74	74	62	74	120	160	190	230	350	430	560	960	1080
7呎(20cm)	84	84	72	84	130	180	230	260	400	490	640	1160	1240
8呎(25cm)	94	94	82	94	150	200	260	290	450	550	720	1320	1440
9呎(27cm)	104	104	90	104	170	230	290	330	500	620	800	1560	1700
10呎(30cm)	120	120	100	120	180	260	320	380	560	700	900	1700	2000

※長度可另依需求訂製

SUS ㊦ 304 不銹鋼管子接頭高級品 150P

品名	簡稱	1/4"-3/8"	1/2"	3/4"	1"	1-1/4"	1-1/2"	2"	2-1/2"	3"	4"
彎頭	L	45	45	65	110	170	230	300	580	800	1700
異徑彎頭	RL	60	60	75	145	210	210	360			
45度彎頭	45'◇L	60	60	75	145	210	265	360	820	1130	1900
接頭	S	40	40	55	90	145	190	250	530	740	1200
異徑接頭	RS	50	60	65	105	165	220	290	610	850	1380
內外牙接頭	X		40	60	100	150	200	250			
三通	T	60	60	90	165	230	300	420	800	1100	2300
異行三通	TR	70	70	110	190	270	350	500			
管帽	CA	40	40	55	90	145	190	250	530	740	1200
卜申	HBU	45	45	50	65	115	160	230	400	500	900
塞頭	P	35	35	50	70	110	140	180	280	370	700
由令	U	150	150	190	260	380	520	650	1700	2300	3700
六角外螺絲	HN	45	45	65	110	170	230	300	580	800	1300
十字通	CR	90	90	110	180	290	410	500			
內外牙彎管	SL	65	65	80	160	230	290	400	900	1200	2000

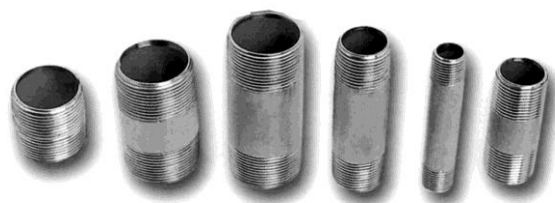

SUS ㊦ 304 不銹鋼立布

規格 長度	1/8"	1/4"	3/8"	1/2"	3/4"	1"	1 1/4"	1 1/2"	2"	2 1/2"	3"	4"
3cm	55	30	30	21	30	55	100	110	160	-	-	-
5cm	72	42	42	29	42	72	100	110	160	250	300	-
7cm	90	56	56	37	56	90	125	135	197	250	300	450
10cm	116	72	72	50	72	116	160	172	252	325	375	680
12cm	133	95	95	58	95	133	185	197	290	370	435	985
15cm	160	110	110	70	110	160	220	234	345	445	510	1060
20cm	203	135	135	91	135	203	280	296	436	565	660	1440
25cm	246	165	165	112	165	246	340	358	530	690	810	1820
30cm	290	190	190	132	190	290	400	420	620	810	960	2200

※長度可另依需求訂製

316 鍛 鋼

名稱 尺寸	90D ELBOW		TEE		CAP HALF CPLG FULL CPLG		UNION
	(套焊 3000#) (牙口 2000#)	牙口 3000#	(套焊 3000#) (牙口 2000#)	牙口 3000#	套焊 3000#	牙口 3000#	套焊、牙口 3000#
1/2"	310	390	420	610	170	185	530
3/4"	390	650	610	860	240	265	695
1"	650	965	860	1350	370	460	1020
1-1/4"	965	1380	1350	1920	590	790	1230
1-1/2"	1380	2250	1920	3200	800	1150	1980
2"	2250	2680	3200	3750	1350	1750	2950

鍛 鋼

名稱 尺寸	90D ELBOW		TEE		CAP HALF CPLG FULL CPLG		UNION
	(套焊 3000#) (牙口 2000#)	牙口 3000#	(套焊 3000#) (牙口 2000#)	牙口 3000#	套焊、牙口 3000#		套焊、牙口 3000#
1/2"	62	82	86	106	43		103
3/4"	82	112	106	150	58		150
1"	112	174	150	250	82		180
1-1/4"	174	230	250	330	122		240
1-1/2"	230	366	330	558	163		354
2"	366	540	558	750	238		498
2-1/2"	1080		1500		420		1380
3"	1836		2340		526		2232
4"	4560		7740		822		7740

304 鍛 鋼

名稱 尺寸	90D ELBOW		TEE		CAP HALF CPLG FULL CPLG		UNION
	(套焊 3000#) (牙口 2000#)	牙口 3000#	(套焊 3000#) (牙口 2000#)	牙口 3000#	套焊 3000#	牙口 3000#	套焊、牙口 3000#
1/2"	220	290	300	385	120	120	360
3/4"	290	450	385	630	160	182	500
1"	450	700	630	960	230	265	690
1-1/4"	700	950	960	1400	360	420	870
1-1/2"	950	1620	1400	2200	510	580	1180
2"	1620	2280	2200	2850	810	930	2120

鍍鋅焊法蘭牌價表

名稱 \ 尺寸	1/2"	3/4"	1"	1 1/4"	1 1/2"	2"	2 1/2"	3"	4"	5"	6"	8"	10"	12"	14"	16"	18"	20"	24"
JIS 10K 規格法蘭	80	102	158	207	230	251	348	365	420	638	848	1007	1578	1818	2192	3075	3944	4688	7260
JIS 10K 規格盲法蘭	87	110	172	231	252	296	438	465	611	969	1341	1859	3014	3692	4927	6972	9136	11415	16712
JIS 10K 普通法蘭	80	102	158	207	215	235	270	287	324	537	693	868	1258	1491	1942	2791	3541	4215	6500
JIS 10K 普通盲法蘭	87	110	172	231	235	242	361	388	509	819	1161	1604	2636	3251	4357	6215	8221	10265	15146
JIS 5K 規格法蘭	65	65	80	109	116	143	199	266	320	432	590	846	1263	1377	1872	2259	2888	3450	6200
JIS 5K 規格盲法蘭	81	81	93	125	139	186	266	359	491	691	996	1620	2563	3227	4409	5564	7038	8606	12958
JIS 20K 規格法蘭	98	112	182	224	238	254	348	508	655	1043	1350	1684	2928	3449	4839	7079	9240	12100	15840
JIS 20K 規格盲法蘭	104	125	209	250	278	319	452	651	916	1461	1979	2882	4940	6480	9030	13200	17144	22023	31547
150#美規正規A型	85	98	125	154	196	294	468	535	722	802	976	1564	2340	3663	4733	5869	6417	8284	12100
150#盲美規正規A型	104	111	151	181	227	336	548	673	963	1178	1527	2644	3862	5835	7794	10201	12482	17037	25833
150# 10K 規格厚B型	85	98	125	154	182	241	374	401	536	668	829	1190	1618	2421	3128	4220	5500	7230	12100
150# 10K 普通厚盲B型	104	111	151	181	209	292	452	518	730	996	1355	2058	3107	4449	5856	8337	11000	14242	19337
2633#DIN PN16 德規	94	131	155	227	260	330	401	520	539	730	878	1245	1791	2326	3823	4131	5715	7556	10855
2633#DIN PN16 德規盲	110	140	171	252	292	382	486	663	750	1118	1381	2165	3333	4674	6387	8446	11553	15155	22162
JIS 10K 規格車牙法蘭	111	134	196	240	252	284	387	388	454										

備註：車 RF 美規內徑，倒前角及其他特殊加工，須另計加工費

※97 年度 6 月份牌價表自 97 年 5 月 26 日起實施

304 不銹鋼法蘭片牌價

規格 \ 尺寸	1/2"	3/4"	1"	1-1/4"	1-1/2"	2"	2-1/2"	3"	4"	5"	6"	8"	10"	12"	14"	16"	18"	20"	24"
10K 規格	201	253	352	388	407	491	679	690	813	1240	1655	1969	3104	3340	5107	7267	9545	10856	14809
10K 盲規格	211	278	383	468	505	621	885	948	1236	1926	2696	3668	5949	7336	11528	16293	22311	26605	38988
10K 普通	168	216	289	315	331	399	530	540	635	1054	1358	1702	2716	2924	4517	6490	8592	9769	13421
10K 盲普通	171	235	315	387	419	508	714	766	1005	1613	2292	3167	5204	6418	10198	14546	20079	23945	35332
5K 規格	158	175	198	264	266	278	391	520	617	837	1154	1647	2497	2724	4383	5284	6970	7499	11472
5K 盲規格	162	186	215	311	325	393	555	732	985	1393	1988	3191	5073	6384	10310	13023	17183	20102	32753
20K 規格	232	292	401	471	500	509	708	998	1298	2019	2622	3291	5713	6809	11255	16073	21589	25239	34270
20K 盲規格	250	317	435	531	577	649	929	1314	1849	2871	3894	5608	9735	12799	21136	30901	41874	51340	76352
150#規格	159	222	288	322	362	556	889	1031	1408	1573	1904	3068	4143	6321	9779	12302	13859	17550	24688
150#盲規格	173	243	321	375	433	698	1138	1388	1980	2369	3055	5288	7724	11672	18478	24188	30883	40262	61048
10K 規格 (牙)	302	353	461	497	516	600	801	804	962										
水道規格						811	892	1109	1298	1541	1892	2487	4190	4865					

(法蘭) JIS 5Kg/Cm2型 FLANGES

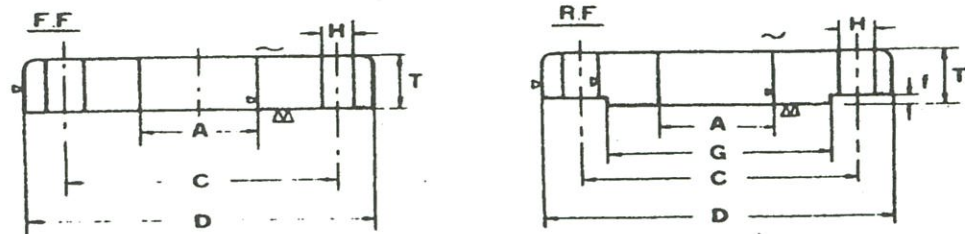

寸法 (B)	内径 A	外径 D	厚 T	座厚 F	座径 G	中心 C	孔大 H	孔数 N	螺絲 稱呼吋
3/8	18	75	9	1	42	55	12	4	3/8
1/2	22.5	80	9	1	48	60	12	4	3/8
3/4	28	85	10	1	52	65	12	4	3/8
1	34.5	95	10	1	62	75	12	4	3/8
1 1/4	43.5	115	12	2	72	90	15	4	1/2
1 1/2	50	120	12	2	78	95	15	4	1/2
2	61.5	130	14	2	88	105	15	4	1/2
2 1/2	77.5	155	14	2	112	130	15	4	1/2

(法蘭) JIS 10Kg/Cm2型 FLANGES

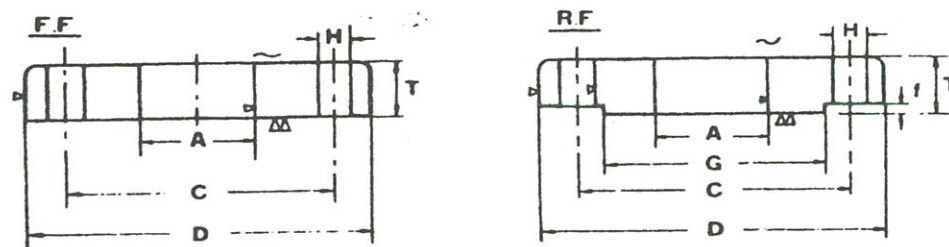

寸法 (B)	内径 A	外径 D	厚 T	座厚 F	座径 G	中心 C	孔大 H	孔数 N	螺絲 稱呼吋
3/8	18	90	12	1	48	65	15	4	1/2
1/2	22.5	95	12	1	52	70	15	4	1/2
3/4	28	100	14	1	58	75	15	4	1/2
1	34.5	125	14	1	70	90	19	4	5/8
1 1/4	43.5	135	16	2	80	100	19	4	5/8
1 1/2	50	140	16	2	85	105	19	4	5/8
2	61.5	155	16	2	100	120	19	4	5/8
2 1/2	77.5	175	18	2	120	140	19	4	5/8

(法蘭) JIS 5Kg/Cm2型 FLANGES

寸法 (B)	内径 A	外径 D	厚 T	座厚 F	座径 G	中心 C	孔大 H	孔数 N	螺絲 稱呼吋
3"	90	180	14	2	125	145	19	4	5/8
3 1/2	103	190	14	2	135	155	19	4	5/8
4	116	200	16	2	145	165	19	8	5/8
5	142	235	16	2	180	200	19	8	5/8
6	167	265	18	2	210	230	19	8	5/8
8	218	320	20	2	255	280	23	8	3/4
10	270	385	22	2	320	345	23	12	3/4
12	320	430	22	3	365	390	23	12	3/4
14	358	480	24	3	405	435	25	12	7/8
16	409	540	24	3	465	495	25	16	7/8
18	459	605	24	3	525	555	25	16	7/8
20	510	655	24	3	575	605	25	20	7/8
22									
24									

(法蘭) JIS 10Kg/Cm2型 FLANGES

寸法 (B)	内径 A	外径 D	厚 T	座厚 F	座径 G	中心 C	孔大 H	孔数 N	螺絲 稱呼吋
3	90	185	18	2	130	150	19	8	5/8
3 1/2	103	195	18	2	140	160	19	8	5/8
4	116	210	18	2	155	175	19	8	5/8
5	142	250	20	2	185	210	23	8	6/8
6	167	280	22	2	215	240	23	8	6/8
8	218	330	22	2	265	290	23	12	6/8
10	270	400	24	2	325	355	25	12	7/8
12	320	445	24	3	370	400	25	16	7/8
14	358	490	26	3	415	445	25	16	7/8
16	409	560	28	3	475	510	27	16	1"
18	459	620	30	3	530	565	27	20	1"
20	510	675	30	3	585	620	27	20	1"
22	561	745	32	3	640	680	33	20	1 1/8
24	612	795	32	3	690	730	33	24	1 1/8

(法蘭) JIS 16Kg/Cm2型 FLANGES

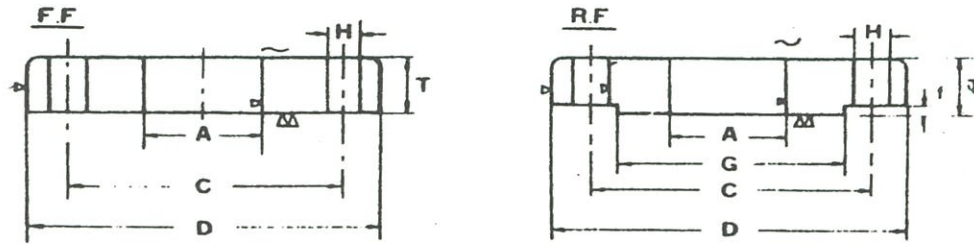

寸法 (B)	内徑 A	外徑 D	厚 T	座徑 G	座厚 F	中心 C	孔大 H	孔數 N	螺絲稱呼吋
3/8	18	90	12	48	1	65	15	4	1/2
1/2	22.5	95	12	52	1	70	15	4	1/2
3/4	28	100	14	58	1	75	15	4	1/2
1	34.5	125	14	70	1	90	19	4	5/8
1 1/4	43.5	135	16	80	2	100	19	4	5/8
1 1/2	50	140	16	85	2	105	19	4	5/8
2	61.5	155	16	100	2	120	19	8	5/8
2 1/2	77.5	175	18	120	2	140	19	8	5/8

(法蘭) JIS 20Kg/Cm2型 FLANGES

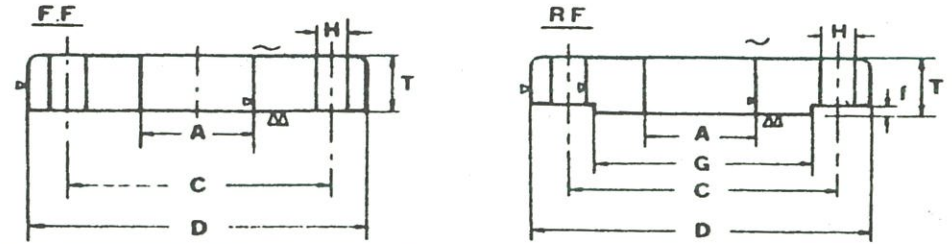

寸法 (B)	内徑 A	外徑 D	厚 T	座徑 G	座厚 F	中心 C	孔大 H	孔數 N	螺絲稱呼吋
3/8	18	90	14	48	1	65	15	4	1/2
1/2	22.5	95	14	52	1	70	15	4	1/2
3/4	28	100	16	58	1	75	15	4	1/2
1	34.5	125	16	70	1	90	19	4	5/8
1 1/4	43.5	135	18	80	2	100	19	4	5/8
1 1/2	50	140	18	85	2	105	19	4	5/8
2	61.5	155	18	100	2	120	19	8	5/8
2 1/2	77.5	175	20	120	2	140	19	8	5/8

(法蘭) JIS 16Kg/Cm2型 FLANGES

寸法 (B)	内徑 A	外徑 D	厚 T	座徑 G	座厚 F	中心 C	孔大 H	孔數 N	螺絲稱呼吋
3	90	200	20	135	2	160	22	8	3/4
3 1/2	103	210	20	145	2	170	22	8	3/4
4	116	225	22	160	2	185	22	8	3/4
5	142	270	22	195	2	225	25	8	7/8
6	167	305	24	230	2	260	25	12	7/8
8	218	350	26	275	2	305	25	12	7/8
10	270	430	28	345	2	380	29	12	1"
12	320	480	30	395	3	430	29	16	1"
14	358	540	34	440	3	480	32	16	1 1/8
16	409	605	38	495	3	540	35	16	1 1/4
18	459	675	40	560	3	605	35	20	1 1/4
20	510	730	42	615	3	660	35	20	1 1/4
22	561	795	44	670	3	720	38	20	1 3/8
24	612	845	46	720	3	770	38	24	1 3/8

(法蘭) JIS 20Kg/Cm2型 FLANGES

寸法 (B)	内徑 A	外徑 D	厚 T	座徑 G	座厚 F	中心 C	孔大 H	孔數 N	螺絲稱呼吋
3	90	200	22	135	2	160	23	8	3/4
3 1/2	103	210	24	145	2	170	23	8	3/4
4	116	225	24	160	2	185	23	8	3/4
5	142	270	26	195	2	225	25	8	7/8
6	167	305	28	230	2	260	25	12	7/8
8	218	350	30	275	2	305	25	12	7/8
10	270	430	34	345	2	380	27	12	1"
12	320	480	36	395	3	430	27	16	1"
14	358	540	40	440	3	480	33	16	1 1/8
16	409	605	46	495	3	540	33	16	1 1/8
18	459	675	48	560	3	605	33	20	1 1/8
20	510	730	50	615	3	660	33	20	1 1/8
22	561	795	52	670	3	720	39	20	1 1/4
24	612	845	54	720	3	770	39	24	1 1/4

(滑套法蘭) ASA 150lb SLIP-ON FLANGES

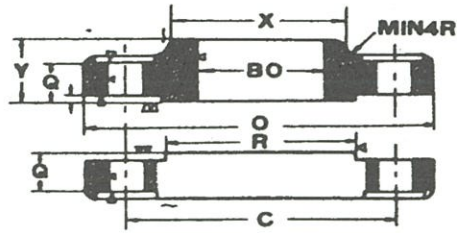

呼徑	外徑	內徑	總厚	最少厚	座徑	後座徑	中心	孔大	孔數	螺絲
B	O	BO	Y	A	R	X	C	H	N	稱呼吋
1/2	89	22.3	15.9	11.2	35	30	60.3	15	4	1/2
3/4	98	27.7	15.9	12.7	43	38	69.8	15	4	1/2
1	108	34.5	17.5	14.3	51	49	79.4	15	4	1/2
1 1/4	117	43.2	20.6	15.9	64	59	88.9	15	4	1/2
1 1/2	127	49.5	22.2	17.5	73	65	98.4	15	4	1/2
2	152	62	25.4	19.1	92	78	120.6	19	4	5/8
2 1/2	178	74.7	28.6	22.3	105	90	139.7	19	4	5/8

(滑套法蘭) ASA 150lb SLIP-ON FLANGES

呼徑	外徑	內徑	總厚	最少厚	座徑	後座徑	中心	孔大	孔數	螺絲
B	O	BO	Y	A	R	X	C	H	N	稱呼吋
3	190	90.7	30.2	23.9	127	108	152.4	19	4	5/8
3 1/2	216	103	31.8	23.9	140	122	178	19	8	5/8
4	229	116.1	33.3	23.9	157	135	190.5	19	8	5/8
5	254	143.8	36.5	23.9	186	164	215.9	22	8	3/4
6	279	170.7	39.7	25.4	216	192	241.3	22	8	3/4
8	343	221.5	44.4	28.6	270	246	298.4	22	8	3/4
10	406	276.3	49.2	30.2	324	305	361.9	25	12	7/8
12	483	327.1	55.6	31.8	381	365	431.8	25	12	7/8
14	533	359.1	57.2	35	413	400	476.2	29	12	1
16	597	410.5	63.5	36.6	470	457	539.7	29	16	1
18	635	461.8	68.3	39.7	533	505	577.8	32	16	1 1/8
20	698	513.1	73	42.9	584	559	635	32	20	1 1/8
24	813	615.9	82.6	47.7	692	664	749.3	35	20	1 1/4

(滑套法蘭) ASA 300lb SLIP-ON FLANGES

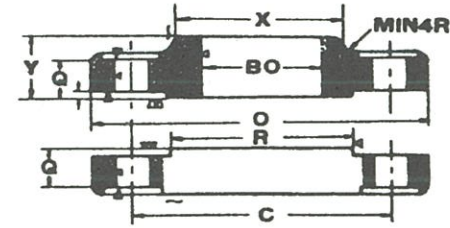

呼徑	外徑	內徑	總厚	最少厚	座徑	後座徑	中心	孔大	孔數	螺絲
B	O	BO	Y	A	R	X	C	H	N	稱呼吋
1/2	95	22.3	22.2	14.3	35	38	66.7	15	4	1/2
3/4	117	27.7	25.4	15.1	43	48	82.5	19	4	5/8
1	124	34.5	27	17.5	51	54	88.9	19	4	5/8
1 1/4	133	43.2	27	19.1	64	64	98.4	19	4	5/8
1 1/2	156	49.5	30.2	20.7	73	70	114.3	22	4	5/8
2	165	62	33.3	22.3	92	84	127	19	8	3/4
2 1/2	190	74.7	38.1	25.4	105	100	149.2	22	8	3/4

(滑套法蘭) ASA 300lb SLIP-ON FLANGES

呼徑	外徑	內徑	總厚	最少厚	座徑	後座徑	中心	孔大	孔數	螺絲
B	O	BO	Y	A	R	X	C	H	N	稱呼吋
3	210	90.7	42.9	28.6	127	117	168.3	22	8	3/4
3 1/2	229	103	44.5	30.2	140	133	184	22	8	3/4
4	254	116.1	47.6	31.8	157	146	200	22	8	3/4
5	279	143.8	50.8	35	186	178	234.9	22	8	3/4
6	318	170.7	52.4	36.6	216	206	269.9	22	12	3/4
8	381	221.5	61.9	41.3	270	260	330.2	25	12	7/8
10	444	276.3	66.7	47.7	324	321	387.3	29	16	1
12	521	327.1	73	50.8	381	375	450.8	32	16	1 1/8
14	584	359.1	76.2	54	413	425	514.3	32	20	1 1/8
16	648	410.5	82.6	57.2	470	483	571.5	35	20	1 1/4
18	711	461.8	88.9	60.4	533	533	628.6	35	24	1 1/4
20	775	513.1	95.2	63.5	584	587	685.8	35	24	1 1/4
24	914	615.9	106.4	69.9	692	702	812.8	41	24	1 1/2

閥類用螺絲對照表

孔數	品名規格	10K 閘閥	10K 逆止	10K 過濾器	10K 蝶閥	10K 無聲逆止	10K 雙瓣逆止	10K 底閥	
		FS051	FS071	FS081	FS041	FS073	FS074	FS075	
		法蘭 2+2P	法蘭 2+2P	法蘭 2+2P	法蘭 2	法蘭 2+2P	法蘭 2	法蘭 1+1P	法蘭對鎖
4	2"	5/8"*2"	5/8"*2"	5/8"*2"	5/8"* 4"	5/8"*2"	5/8"*4 1/2"	5/8"*2 1/2"	5/8"*2"
4	2-1/2"	5/8"*2 1/2"	5/8"*2 1/2"	5/8"*2 1/2"	5/8"* 4 1/2"	5/8"*2 1/2"	5/8"*4 1/2"	5/8"*2 1/2"	5/8"*2 1/2"
8	3"	5/8"*2 1/2"	5/8"*2 1/2"	5/8"*2 1/2"	5/8"* 4 1/2"	5/8"*2 1/2"	5/8"*4 1/2"	5/8"*2 1/2"	5/8"*2 1/2"
8	4"	5/8"*2 1/2"	5/8"*2 1/2"	5/8"*2 1/2"	5/8"* 4 1/2"	5/8"*2 1/2"	5/8"* 5"	5/8"*2 1/2"	5/8"*2 1/2"
8	5"	3/4"*2 1/2"	3/4"*2 1/2"	3/4"*2 1/2"	3/4"*4 1/2"	3/4"*2 1/2"	3/4"* 6"	3/4"*2 1/2"	3/4"*2 1/2"
8	6"	3/4"*2 1/2"	3/4"*2 1/2"	3/4"*2 1/2"	3/4"*4 1/2"	3/4"*2 1/2"	3/4"*6 1/2"	3/4"*2 1/2"	3/4"*2 1/2"
12	8"	3/4"*2 1/2"	3/4"*2 1/2"	3/4"*2 1/2" OR 3"	3/4"*6" or 5 1/2"	3/4"*2 1/2"	3/4"*6 1/2"	3/4"*2 1/2"	3/4"*2 1/2"
12	10"	7/8"*2 1/2"	7/8"*2 1/2"	7/8"*4"	7/8"* 6"			7/8"*3" or 3 1/2"	
16	12"	7/8"*2 1/2"		7/8"*4"	7/8"* 6 1/2"			7/8"*5"	
螺絲組		2	2	2	1	2	1	1	

***** 16K/20K 螺絲+ 1/2"長

鍍鋅有縫焊另件 20S

規 品 名 格	90°彎頭	45°彎頭	三通
1/2"	75	75	265
3/4"	90	75	300
1"	100	85	350
1 1/4"	125	125	415
1 1/2"	155	150	375
2"	240	190	475
2 1/2"	440	225	840
3"	545	295	1000
4"	870	545	1250
5"	1580	805	2050
6"	2070	1300	3010
8"	5170	3090	5500
10"	7335	5000	9335
12"	12000	6235	16600
14"	15935	12295	18390
16"	23730	16350	21095

規 品 名 格	同心大小頭	異徑三通	規 品 名 格	同心大小頭	異徑三通
3/4"*1/2"	140	385	4"*2"	635	1130
1"*3/4"	160	445	4"*1 1/2"	680	1145
1"*1/2"	160	445	4"*1 1/4"	775	1145
1 1/4"*1"	160		4"*1"	830	1145
1 1/4"*3/4"	160		5"*4"	855	2185
1 1/4"*1/2"	180		5"*3"	970	2185
1 1/2"*1 1/4"	235	540	5"*2 1/2"	1010	2110
1 1/2"*1"	235	540	5"*2"	1245	2110
1 1/2"*3/4"	235	660	6"*5"	1235	2835
2"*1 1/2"	245	655	6"*4"	1150	2835
2"*1 1/4"	265	655	6"*3"	1300	3165
2"*1"	265	735	6"*2 1/2"	1670	3300
2"*3/4"	305	930	6"*2"	1735	3630
2 1/2"*2"	335	800	6"*1 1/2"		2995
2 1/2"*1 1/2"	335	800	8"*6"	1810	5375
2 1/2"*1 1/4"	380	800	8"*5"	2000	5375
2 1/2"*1"	380	800	8"*4"	2160	5375
3"*2 1/2"	435	900	8"*3"	2465	5375
3"*2"	435	900	10"*8"	2640	9340
3"*1 1/2"	495	900	10"*6"	3200	11470
3"*1 1/4"	495	900	10"*5"	3535	13600
3"*1"	620	900	12"*10"	4330	14315
4"*3"	605	1130	12"*8"	4750	14315
4"*2 1/2"	605	1130	12"*6"	4900	15800

鍍鋅有縫焊另件 40S

規 品 名 格	90°彎頭	45°彎頭	三通	管帽
1/2"	120	95	265	145
3/4"	130	100	300	145
1"	135	120	350	145
1 1/4"	160	150	415	145
1 1/2"	200	160	375	165
2"	300	190	475	285
2 1/2"	490	295	870	305
3"	670	370	1035	320
4"	1340	695	1470	470
5"	2300	1185	2505	740
6"	2810	2150	4145	1335
8"	5690	4340	6780	2145
10"	12335	5890	13560	3435
12"	15060	9335	18455	5005
14"	18675	14000	27085	8060
16"	32390	18195	38335	9835

規 品 名 格	同心大小頭	異徑三通	規 品 名 格	同心大小頭	異徑三通
3/4"*1/2"	140	385	4"*2"	715	1600
1"*3/4"	160	445	4"*1 1/2"	715	1600
1"*1/2"	160	445	4"*1 1/4"	715	1545
1 1/4"*1"	160	485	4"*1"	780	1545
1 1/4"*3/4"	160	515	5"*4"	1100	2535
1 1/4"*1/2"	180	570	5"*3"	1100	2535
1 1/2"*1 1/4"	265	540	5"*2 1/2"	1280	2640
1 1/2"*1"	265	540	5"*2"	1430	2640
1 1/2"*3/4"	310	660	6"*5"	1580	3690
2"*1 1/2"	295	655	6"*4"	1580	3690
2"*1 1/4"	295	655	6"*3"	1580	3500
2"*1"	355	735	6"*2 1/2"	1660	3500
2"*3/4"	380	930	6"*2"	2070	4145
2 1/2"*2"	440	770	6"*1 1/2"	2240	4830
2 1/2"*1 1/2"	440	770	8"*6"	2270	6630
2 1/2"*1 1/4"	590	905	8"*5"	2395	6630
2 1/2"*1"	590	770	8"*4"	2650	6330
3"*2 1/2"	400	1035	8"*3"	2950	6685
3"*2"	400	1035	10"*8"	4135	12055
3"*1 1/2"	435	965	10"*6"	4335	15535
3"*1 1/4"	600	965	10"*5"	4925	18175
3"*1"	715	1035	12"*10"	5600	18665
4"*3"	720	1600	12"*8"	5725	18665
4"*2 1/2"	700	1600	12"*6"	5395	18665

SUS-304眾鉅不銹鋼雙壓著接頭

眾鉅工業股份有限公司成立於1997年，專業生產高密度聚乙烯防蝕被覆鋼管、聚乙烯發泡包覆不銹鋼管、銅管。我們以完整優秀的技術團隊，製造生產ZHONG JU不銹鋼雙壓著接頭管件，提供國人密封性更好、連接更牢固、通用性更強、更安全經濟的雙壓著接頭管件產品。

ZHONG JU不銹鋼雙壓著接頭管件，採用國內獲得正字標記不銹鋼管廠生產SUS 304 (CNS 13392 G3258 JIS G3448)不銹鋼壓接管為本體材料在台生產製造之雙壓接管件，該產品取得TAF ISO9001認證於2013年7月15日為國內首家榮獲經濟部標準檢驗局CNS 14645一般配管用不銹鋼鋼管接頭正字標記認證製造廠。

不銹鋼壓接管接頭連接原理

不銹鋼壓接管、不銹鋼雙壓著接頭、專用壓接擠壓工具三部分

雙壓著接頭管件端部凸出U型槽內裝有特製抗老化、食品級O型密封膠圈「EPDM」材質，安裝時將不銹鋼壓接管插入不銹鋼雙壓著接頭承口到定位階段，用專用壓接擠壓工具在雙壓著接頭管端部擠壓，O型密封膠圈受擠壓後產生壓縮密封作用，不銹鋼雙壓著接頭管件與不銹鋼壓接管同時產生收縮變形，而達到定位固定完全密合效果，執行了管道連接安裝。

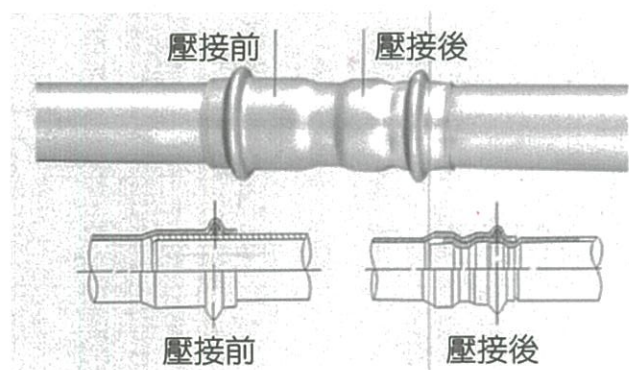

單壓著接頭管件壓接完成品~只有單邊無凸緣

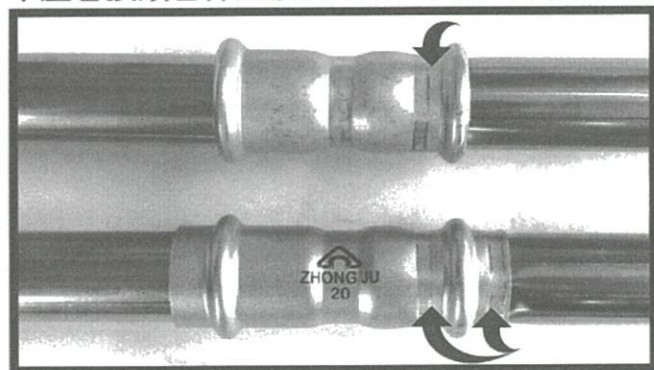

雙壓著接頭管件壓接完成品~有雙邊有凸緣

ZHONG JU雙壓著接頭產品材質：

管材：JIS G3448 (SUS304TPD)

CNS 13392 (304TPD)

外徑：15.88-60.5mm 厚度：0.8-1.5mm

膠圈：符合CNS-10774、JWWA-G116、SAS-322

O型密封膠圈「EPDM」材質。

使用溫度：-40°C~130°C。

適用溫度：建議適用溫度於80°C以下。

水壓試驗：25Kg以上。



雙壓著接頭特性：

1. 雙壓接管件尺寸精度提高，允許管材的誤差值增大，適配性更強。
2. 雙壓著接頭提高抗拔出力道，亦適用於高水壓建築層建物。
3. 雙壓接管件附有凸緣，壓接管插入時有導管作用，不會損壞O型密封膠圈，確保工程品質。
4. 鋼雙壓著接頭O型密封膠圈經壓接後完全密封在不銹鋼壓接管材內，密封膠圈使用耐久性顯著提高。
5. 雙壓著接頭受安裝擠壓接時，O型密封膠圈左右受擠壓力道均勻膠圈完全密合，密封膠圈不會因擠壓不當或從另側面被水壓擠出，彌補單壓接頭壓接過程中的缺點與不足。
6. 雙壓著接頭因附有凸緣密合性高，壓接安裝後之導管受外力折彎、變型也不會對密封膠圈產生破壞。

雙壓著接頭與單壓著接頭比較

名稱	雙壓著接頭	單壓著接頭
外觀	管件O型密封膠圈外側端有凸緣	管件O型膠圈外側端無凸緣
材質	SUS 304不銹鋼	SUS 304不銹鋼
壓接點	于管件O型密封膠圈雙邊兩側	于管件O型密封膠圈單邊內側
抗水壓試驗	耐壓強度強	耐壓強度弱
拉拖值試驗	抗拉強度強	抗拉強度弱
O型密封膠圈	壓接後完全密封於不銹鋼材料內 受壓力分佈均勻，不會被擠出	壓接後無法完全密封 受壓力道分佈不均，易被擠出
外力扭曲震動	不受外力影響，變形彎曲不漏水	受外力影響，易鬆脫、變形、漏水
施工品質	管件有凸緣，壓接管插入時有導管保護O型密封膠圈作用，確保工程品質。	管件端口O型密封膠圈顯露，壓接管插入角度小，施工不慎較易損壞O型密封膠圈，造成擠壓後漏水現象。

雙壓著接頭、單壓著接頭壓接結構分析對比圖表

<p>不影響密封 不會漏水</p> <p>雙壓接管件，折彎不漏水，強震動不漏水，旋轉不漏水，鬆動也不漏水</p>	<p>雙壓接密封</p> <p>膠圈全密封在不銹鋼內</p>	<p>雙壓接結構密封圈</p> <p>壓力分佈均勻</p> <p>密封圈無法被擠出</p> <p>雙邊卡壓，接口不易鬆動</p>
<p>密封鬆動 發生漏水</p> <p>單壓接擠壓口不允許鬆動，否則會漏水</p>	<p>單壓接密封</p> <p>膠圈不完全密封</p>	<p>單壓接結構密封圈</p> <p>壓力分佈不均 密封圈易擠出</p> <p>接口易鬆動</p>

ZHONG JU不銹鋼雙壓著接頭測試標準 CNS 14645 B2811

試驗項目	SAS 322 不銹鋼協會規格	JWWA G116 日本水道協會之規格	CNS14645 B2811	持續時間	合格要求	ZHONG JU 25Su 公證單位測驗結果
氣密試驗	0.6MPa	0.6MPa	0.6MPa { 6.1kgf/cm ² } 空氣壓，錶壓	5sec	無洩漏	氣壓6.3kgf/cm ² 無洩漏
耐壓試驗	2.5MPa { 25kgf/cm ² }	2.5MPa { 25kgf/cm ² } 時間為一分鐘	2.5MPa { 25kgf/cm ² } 水壓，錶壓	2min	無洩漏、破壞 及其他異常	水壓25.5kgf/cm ² 無洩漏、破壞及 其他異常
負壓試驗	減壓至-96kPa { -720mmHg }	減壓至54kPa { 400mmHg絕對壓力 }	減壓至5.33kPa絕對壓力 { 40mmHg絕對壓力 }	2min	無吸入空氣	絕對壓力40mmHg { -720mmHg錶壓 } 無吸入空氣
水壓試驗	2.5MPa { 25kgf/cm ² }	2.5MPa { 25kgf/cm ² }	2.5MPa { 25kgf/cm ² } 水壓，錶壓	2min	無洩漏、脫落	水壓25.5kgf/cm ² 無洩漏
拉伸試驗	封入0.2Mpa空氣壓， 以2mm/min的拉拔速度， 測量空氣露出前的 最大荷重。	封入0.6Mpa空氣壓， 以2mm/min 速度拔出， 測定發生滲漏之最大 負荷量。	封入0.2Mpa { 2.0kgf/cm ² } 空氣壓，錶壓	拉伸至 發生洩漏為止	拔出阻力 應符合 表2之要求	25Su拔出阻力kgf 規範值≥320kgf 測試值780kgf 無洩漏

配件

品質檢測

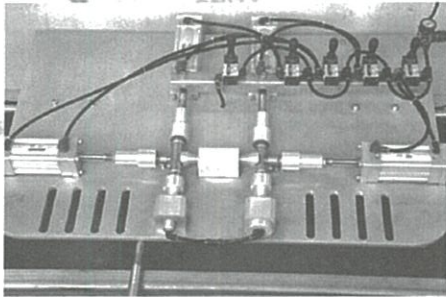

氣密試驗 (氣壓6.1kgf/cm²)

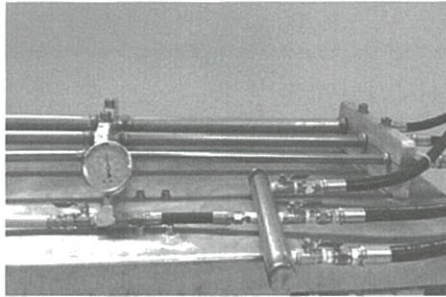

擺動水壓試驗 (水壓加至25kgf/cm²)

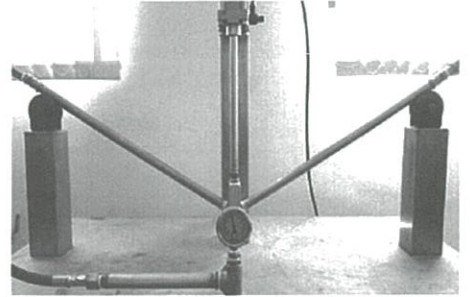

耐壓試驗、水壓試驗、彎曲試驗
(水壓加至25kgf/cm²)

施工方法及安裝注意事項

1. 採用切管器裁切不銹鋼壓接管材

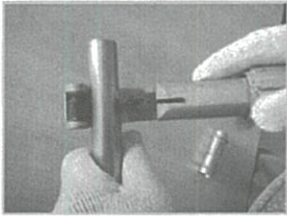

壓接管切管時需使用圓輪切管器，裁切壓接管時動作不得造成管端變形或縮小，嚴禁使用砂輪機切管。

2. 壓接管原管兩端管口及經裁切後管端所產生之毛邊或尖刺須確實清除

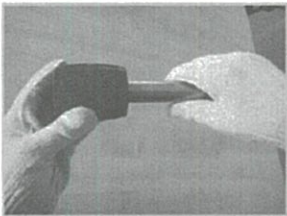

壓接管原管兩端管口及經裁切後管端留有毛邊或尖刺，務必使用銼刀或砂紙完全去除毛邊或尖刺，以避免壓接管插入壓著接頭時損傷破壞O型密封膠圈而影響施工品質。

3. 檢查O型密封膠圈

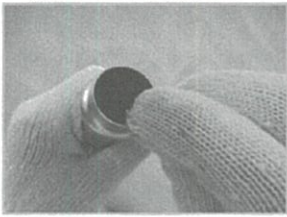

檢查O型密封膠圈對位是否正確，是否貼合凹槽。

4. 將壓接管完全插入雙壓著接頭壓接定位點

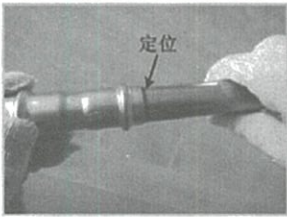

不銹鋼壓接管插入雙壓著接頭前需使用劃線器在壓接管端處做定位標記，確定壓接管插入到壓接定位點，壓接管插入雙壓著接頭時應注意切勿挫傷損壞O型密封膠圈。

5. 注意壓接工具鉗口應置放在雙壓著接頭正確壓接位置

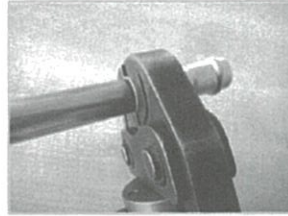

確認壓接工具鉗口之凹槽處完整置放在雙壓著接頭密封膠圈凸緣處，形成緊密狀態後啟動加壓，完成壓接程序。

6. 壓接後之雙壓著接頭尺寸符合檢測要求

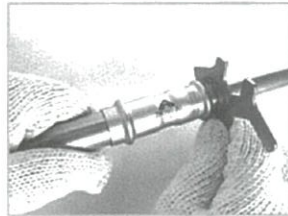

經壓接後之雙壓著接頭處需使用六角量規檢測，壓接處能完全卡入六角量規才能符合壓接標準，並表示壓接工具鉗性能標達標，整個不銹鋼壓接過程才算執行完成。

7. 裝套盒蓋

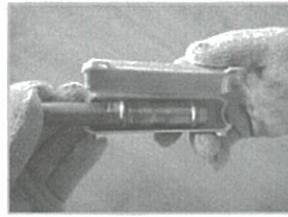

使用發泡保溫管材的最後，在壓著接頭處裝上盒蓋，預留管路配件外圍有足夠的伸縮空間以保護壓著接頭，防止震動或熱脹損傷破壞。

※ 雙壓著接頭管件經壓接後之剖面狀態 ※

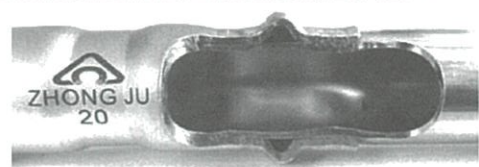

應用範圍

建築配管、動力氣體配管、工業配管、設備配管

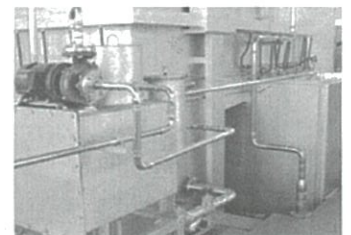

配件









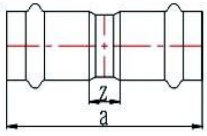

SUS304

CNS14645 一般配管用不銹鋼鋼管接頭

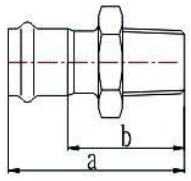

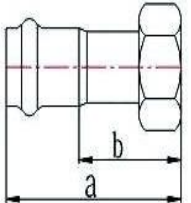

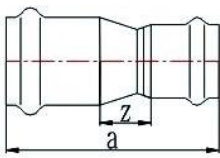

眾鉅雙壓著接頭管件規格表

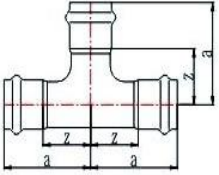
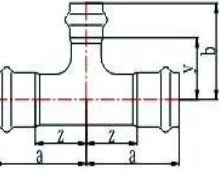
(雙壓接)

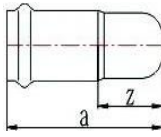
<p>90 E</p>	<p>90° 彎頭</p>	規格口徑	a	z	裝箱數	包裝數	牌價	
		13	55	27	600	25	119	
		20	66	36	300	15	163	
		25	82	48	160	10	190	
		30	108	55	80	8	551	
		40	130	70	48	6	985	
		50	148	80	32	4	1050	
60	161	83	20	2	2316			
<p>45 E</p>	<p>45° 彎頭</p>	規格口徑	a	z	裝箱數	包裝數	牌價	
		13	40	12	750	30	122	
		20	48	16	400	20	161	
		25	56	18	240	15	183	
		30	77	22	120	8	742	
		40	92	27	60	6	913	
		50	101	32	50	5	984	
60	131	49	24	2	2316			
<p>90 SE(L)</p>	<p>內牙彎頭(長)</p>	規格口徑	a	b	z	裝箱數	包裝數	牌價
		13×1/2"	55	51	27	600	25	264
		20×1/2"	66	61	36	300	15	343
		20×3/4"	66	63	36	240	15	364
		25×1"	82	76	48	150	10	545
		30×1 1/4"	108	85	55	80	8	2041
		40×1 1/2"	130	94	70	48	68	2539
50×2"	148	105	80	32	4	2947		
<p>90 EM</p>	<p>外牙彎頭</p>	規格口徑	a	b	z	裝箱數	包裝數	牌價
		13×1/2"	55	52	27	600	25	261
		20×3/4"	66	63	36	240	15	354
		25×1"	82	81	48	150	10	508
		30×1 1/4"	108	106	55	80	8	1767
		40×1 1/2"	130	116	70	48	6	2183
		50×2"	148	140	80	32	4	2558
<p>90 SE(3)</p>	<p>內牙彎頭(短)</p>	規格口徑	a	b	z	裝箱數	包裝數	牌價
		13×1/2"	58	28	27	600	25	315
		20×1/2"	62	30	28	300	20	461
		20×3/4"	64	35	33	240	20	592

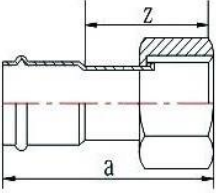
<p>S</p> 	<p>直接接頭</p> 	規格口徑	a	z	裝箱數	包裝數	牌價
		13	67	11	1000	50	68
		20	76	12	500	25	96
		25	84	12	300	20	111
		30	127	22	160	10	409
		40	144	22	96	8	479
		50	160	22	50	5	545
		60	182	24	30	3	1158
<p>SM</p> 	<p>外牙接頭</p> 	規格口徑	a	z	裝箱數	包裝數	牌價
		13×1/2"	61	36	880	40	209
		20×3/4"	70	40	450	25	258
		25×1"	75	44	300	20	327
		30×1 1/4"	97	65	150	10	803
		40×1 1/2"	108	65	96	8	1004
		50×2"	121	76	50	5	1291
		60×2 1/2"	165	85	30	3	3702
<p>SS</p> 	<p>內牙接頭</p> 	規格口徑	a	z	裝箱數	包裝數	牌價
		13×1/2"	60	32	880	40	226
		20×1/2"	66	33	500	25	301
		20×3/4"	68	35	450	25	304
		25×1/2"	72	38	400	20	359
		25×3/4"	74	39	400	20	442
		25×1"	74	41	300	20	458
		30×1 1/4"	93	42	150	10	891
		40×1 1/2"	103	42	96	8	1049
		50×2"	117	48	50	5	1357
60×2 1/2"	163	83	30	3			
<p>RS</p> 	<p>異徑接頭</p> 	規格口徑	a	z	裝箱數	包裝數	牌價
		20×13	75	15	1000	50	124
		25×13	94	28	800	40	244
		25×20	82	16	340	20	149
		30×13	124	36	300	20	619
		30×20	118	28	300	15	611
		30×25	112	17	180	15	447
		40×13	144	48	120	12	769
		40×20	137	39	120	12	761
		40×25	135	31	80	8	603
		40×30	142	24	80	8	564
		50×13	157	57	84	12	931
		50×20	156	48	84	12	927
		50×25	147	39	84	12	769
		50×30	162	32	56	8	723
		50×40	155	34	56	8	642
		60×30	197	68	40	4	
60×40	197	59	30	4	2844		
60×50	186	41	36	3	2470		

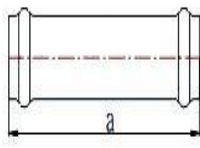
<p>3T</p> 	<p>等徑三通</p> 	規格口徑	a	z	裝箱數	包裝數	牌價		
		13	44	16	500	25	258		
		20	53	21	200	10	324		
		25	62	26	120	10	399		
		30	82	28	60	6	1150		
		40	97	35	32	4	1725		
		50	106	38	24	3	1860		
		60	135	57	12	2	4422		
<p>3TF</p> 	<p>內牙三通</p> 	規格口徑	a	b	z	裝箱數	包裝數	牌價	
		13×1/2"	45	41	16	450	25	387	
		20×1/2"	53	47	21	160	10	446	
		20×3/4"	53	48	21	160	10	496	
		25×1/2"	62	50	26	100	10	542	
		25×3/4"	62	48	26	100	10	715	
		25×1"	62	49	26	100	10	914	
<p>3TR</p> 	<p>異徑三通</p> 	規格口徑	a	b	y	z	裝箱數	包裝數	牌價
		20×13	52	48	21	21	220	10	312
		25×13	52	51	24	16	200	10	429
		25×20	62	55	21	26	200	10	393
		30×13	71	54	27	20	90	6	1460
		30×20	71	58	28	20	90	6	1453
		30×25	82	63	30	28	60	6	1353
		40×13	82	58	32	20	56	4	2106
		40×20	82	63	33	20	52	4	2018
		40×25	96	67	36	35	40	4	1957
		40×30	96	86	35	35	40	4	1926
		50×13	96	63	35	29	36	3	2390
		50×20	96	68	36	29	36	3	2272
		50×25	96	72	38	29	30	3	2140
		50×30	107	90	37	39	30	3	2078
		50×40	107	102	41	39	30	3	2008
		60×30	123	97	46	44	16	2	4506
		60×40	123	108	47	44	16	2	4464
		60×50	123	115	48	44	18	2	4440
		60×25	112	79	35	27	16	2	2712
60×25	112	75	34	27	16	2			

		規格口徑	a	z	裝箱數	包裝數	牌價
		13	40	11	1500	50	146
		20	46	16	800	40	168
		25	52	18	480	30	194
		30	76	26	240	12	627
		40	85	26	150	10	702
		50	93	26	96	8	900
		60	120	30	64	6	1884
		規格口徑	a	z	裝箱數	包裝數	牌價
		13×1/2"	52	29	1000	40	470
		20×3/4"	65	33	500	25	725
		25×1"	71	40	240	20	965
		30×1 1/4"	95	44	120	10	1498
		40×1 1/2"	104	52	80	8	2228
		50×2"	120	57	50	5	2890
		規格口徑	a		裝箱數	包裝數	牌價
		13	130			25	171
		20	140			15	195
		25	160			10	230

型錄圖表尺寸如有修改不另通知

不銹鋼雙壓著接頭壓接工具、配件

CBS-25A 尖嘴式壓接工具 	CBL-60-A 
出力 5TON 重量 5.6kg ●盒裝	出力 20TON 重量 9.5kg ●盒裝

工作壓力參考表

接管 / 規格	工作壓力kg	品號	管徑壓著模具規格	
13 Su	400-550	CBS-25A	13 Su	1/2"
20 Su	400-550		20 Su	3/4"
25 Su	400-550		25 Su	1"
30 Su	400-600	CBL-60-A	30 Su	1 1/4"
40 Su	400-600		40 Su	1 1/2"
50 Su	400-600		50 Su	2"
60 Su	400-600		60 Su	2 1/2"

ROMAX® AC ECO 油壓式不銹鋼管壓接機 			
特性 ● 運作重力為油壓式軸心永恆出力32KN ● 高等級可信賴性油壓缸，耐壓超過10000PSI(70MPa) ● 固定壓著接頭插梢有180°迴轉，安全性高不易脫落 ● 容易操作緊急停止按鈕，當超過最大極限時可立即中斷工作 ● 強而有力的馬達，使用壽命長 ● 壓著模具可以尺寸不同更換 ● 壓著鉗可270°旋轉便利作業 ● 壓接完成自動復歸裝置 ● 握把依人體工學平衡設計易操作 ● 隱藏式安全性開關			
能力	電源	標準配備	選配
可壓接至54φmm	110V 50/60Hz 2.4A 280W	壓著模具：13.20.25 SU各一個 收納箱×1個、保養布×1條、附電源線五米長	壓著模具 30su.40su.50su

手動切管器 	電動切管器 
--	---

CTE-25AS (台製) 電動式遙控幫浦 	<table border="1"> <thead> <tr> <th>型式</th> <th>馬力KW</th> <th>迴轉數</th> <th>容量L</th> </tr> </thead> <tbody> <tr> <td>押扣開關</td> <td>1HR</td> <td>12000</td> <td>4.0L</td> </tr> <tr> <td>電壓</td> <td>相位</td> <td>高壓</td> <td>出油量</td> </tr> <tr> <td>110V</td> <td>單相</td> <td>700kg/cm²</td> <td>0.2L/min</td> </tr> <tr> <td>低壓</td> <td>出油量</td> <td>重量</td> <td>配件</td> </tr> <tr> <td>50kg/cm²</td> <td>2.2L/min</td> <td>13kg</td> <td>2M</td> </tr> </tbody> </table>	型式	馬力KW	迴轉數	容量L	押扣開關	1HR	12000	4.0L	電壓	相位	高壓	出油量	110V	單相	700kg/cm ²	0.2L/min	低壓	出油量	重量	配件	50kg/cm ²	2.2L/min	13kg	2M
型式	馬力KW	迴轉數	容量L																						
押扣開關	1HR	12000	4.0L																						
電壓	相位	高壓	出油量																						
110V	單相	700kg/cm ²	0.2L/min																						
低壓	出油量	重量	配件																						
50kg/cm ²	2.2L/min	13kg	2M																						

● 係有線式遙控，並可遙控幫浦。

UP-35RH (台製) 自動回油幫浦 	<table border="1"> <thead> <tr> <th>型式</th> <th>馬力KW</th> <th>迴轉數</th> <th>容量L</th> </tr> </thead> <tbody> <tr> <td>押扣開關</td> <td>1HR</td> <td>—</td> <td>0.8L</td> </tr> <tr> <td>電壓</td> <td>相位</td> <td>高壓</td> <td>出油量</td> </tr> <tr> <td>110V</td> <td>單相</td> <td>700kg/cm²</td> <td>0.2L/min</td> </tr> <tr> <td>低壓</td> <td>出油量</td> <td>重量</td> <td>配件</td> </tr> <tr> <td>10kg/cm²</td> <td>2.2L/min</td> <td>7.5kg</td> <td>2M</td> </tr> </tbody> </table>	型式	馬力KW	迴轉數	容量L	押扣開關	1HR	—	0.8L	電壓	相位	高壓	出油量	110V	單相	700kg/cm ²	0.2L/min	低壓	出油量	重量	配件	10kg/cm ²	2.2L/min	7.5kg	2M
型式	馬力KW	迴轉數	容量L																						
押扣開關	1HR	—	0.8L																						
電壓	相位	高壓	出油量																						
110V	單相	700kg/cm ²	0.2L/min																						
低壓	出油量	重量	配件																						
10kg/cm ²	2.2L/min	7.5kg	2M																						

CP-700 超高壓油壓幫浦 	<table border="1"> <thead> <tr> <th>最高使用壓力kg/cm²</th> <th>活塞直徑</th> <th colspan="2">輸出油量 cc</th> </tr> <tr> <th>高壓</th> <th>低壓</th> <th>低壓2</th> <th>高壓1 低壓2</th> </tr> </thead> <tbody> <tr> <td>700</td> <td>20</td> <td>12.0</td> <td>28.0 2.3 13.0</td> </tr> </tbody> </table>	最高使用壓力kg/cm ²	活塞直徑	輸出油量 cc		高壓	低壓	低壓2	高壓1 低壓2	700	20	12.0	28.0 2.3 13.0
最高使用壓力kg/cm ²	活塞直徑	輸出油量 cc											
高壓	低壓	低壓2	高壓1 低壓2										
700	20	12.0	28.0 2.3 13.0										
<table border="1"> <thead> <tr> <th>接頭口徑</th> <th>儲油量</th> <th>重量</th> <th>材積</th> <th>配件</th> </tr> </thead> <tbody> <tr> <td>PT 3/8</td> <td>900cc</td> <td>10.8kg</td> <td>1.5'</td> <td>2M</td> </tr> </tbody> </table>	接頭口徑	儲油量	重量	材積	配件	PT 3/8	900cc	10.8kg	1.5'	2M	● 盒裝		
接頭口徑	儲油量	重量	材積	配件									
PT 3/8	900cc	10.8kg	1.5'	2M									

SUS304 CNS14645 一般配管用不銹鋼鋼管接頭

壓著接頭管件規格表 (單壓接)

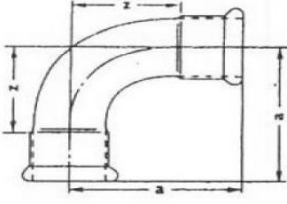
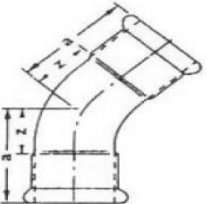
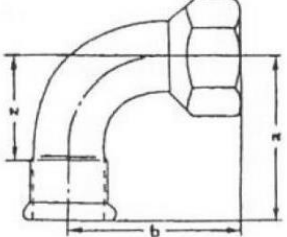
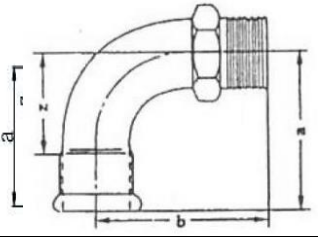
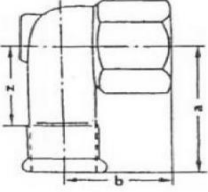

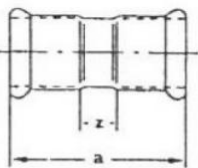
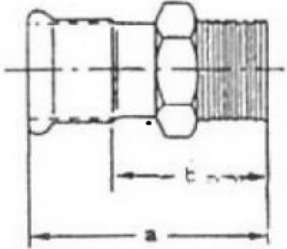
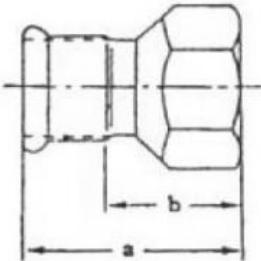
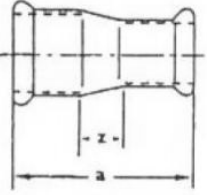
<p>90 E 90° 彎頭</p> 	規格口徑	a	z			牌價
	13	48	27			38
	20	58	34			48
	25	66	42			63
	30	91	52			138
	40	110	70			169
	50	122	80			225
60	150	83			772	
<p>45 E 45° 彎頭</p> 	規格口徑	a	z			牌價
	13	36	15			38
	20	42	18			48
	25	46	22			63
	30	67	28			138
	40	79.5	32.5			169
	50	87.5	33.5			225
60	107	43			772	
<p>90 SE (L) 內牙彎頭 (長)</p> 	規格口徑	a	b	z		牌價
	13×1/2"	48	48	27		102
	20×1/2"	58	57	34		125
	20×3/4"	58	55	34		140
	25× 1"	66	67	42		195
	30×1 1/4"	91	67	52		357
	40×1 1/2"	110	80	63		448
50× 2"	122	87	70		592	
<p>90 EM 外牙彎頭</p> 	規格口徑	a	b	z		牌價
	13×1/2"	48	52	27		105
	20×3/4"	58	62	34		150
	25× 1"	66	73	42		195
	30×1 1/4"	91	81	52		358
	40×1 1/2"	110	98	63		455
	50× 2"	122	107	70		582
<p>90 SE (S) 內牙彎頭 (短)</p> 	規格口徑	a	b	z		牌價
	13×1/2"	48	27	27		180
	20×1/2"	52	30	28		313
	20×3/4"	54	34	30		324
	25× 1"	63	38	38		360

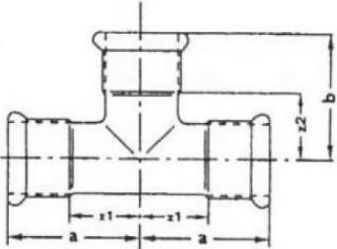
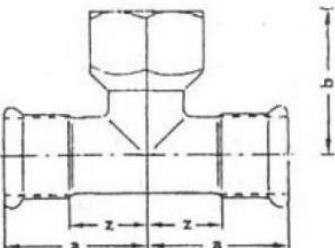
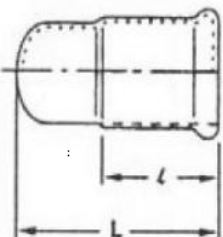
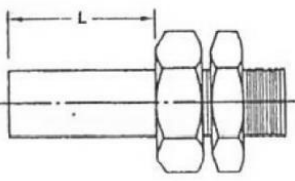
S 直接接頭 	規格口徑	a	z		牌價
	13	53	11		29
	20	60	12		40
	25	60	12		52
	30	100	22		104
	40	116	22		134
	50	126	22		159
	60	154	26		386
SM 外牙接頭 	規格口徑	a	b		牌價
	13×1/2"	57	36		102
	20×3/4"	64	40		140
	25× 1"	68	44		182
	30×1 1/4"	90	51		283
	40×1 1/2"	104	57		422
	50× 2"	111	59		505
	60×2 1/2"	133	69		1234
SS 內牙接頭 	規格口徑	a	b		牌價
	13×1/2"	53	32		102
	20×1/2"	57	33		125
	20×3/4"	59	15		140
	25×1/2"	63	39		168
	25×3/4"	65	41		160
	25× 1"	62	38		182
	30×1 1/4"	76	37		293
	40×1 1/2"	86	39		393
	50× 2"	91	39		487
	60×2 1/2"	109	45		1232
RS 異徑接頭 	規格口徑	a	z		牌價
	20×13	60	15		63
	25×13	76	30		105
	25×20	64	16		96
	30×13	105	45		183
	30×20	103	40		182
	30×25	90	27		170
	40×13	123	55		246
	40×20	121	50		232
	40×25	121	50		228
	40×30	122	36		224
	50×13	133	60		471
	50×20	131	55		455
	50×25	131	55		393
	50×30	146	55		362
	50×40	133	34		334
	60×30	168	65		1046
60×40	176	65		948	

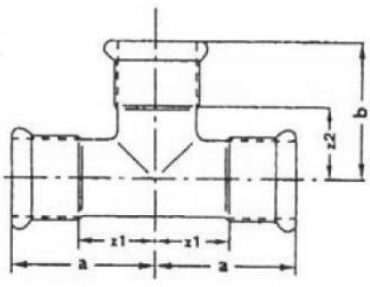
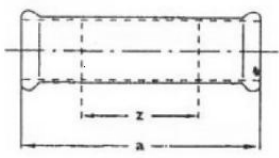
<p style="text-align: center;">3T 等徑三通</p> 	規格口徑	a	z			牌價
	13	38	12			94
	20	46	22			123
	25	51	27			148
	30	99	60			413
	40	107	60			526
	50	102	50			620
	60	127	63			1474
<p style="text-align: center;">3TF 內牙三通</p> 	規格口徑	a	b	z		牌價
	13×1/2"	38	41	17		152
	20×1/2"	46	47	22		182
	20×3/4"	46	45	22		206
	25×1/2"	51	50	27		215
	25×3/4"	51	52	27		238
	25×1"	51	54	27		271
<p style="text-align: center;">C 塞頭</p> 	規格口徑	a	z			牌價
	13	21	31			52
	20	24	42			67
	25	24	44			81
	30	46	85			209
	40	46	93			234
	50	46	98			300
	60	48	112			628
<p style="text-align: center;">U 由令</p>  <p style="text-align: center;">(閥類、設備專用)</p>	規格口徑	l				牌價
	13×1/2"	80				188
	20×3/4"	90				290
	25×1"	100				386
	30×1 1/4"	100				599
	40×1 1/2"	100				891
	50×2"					1156

3TR 異徑三通		規格口徑	a	b	y	z		牌價	
	20×13	46	42	22	21			119	
	25×13	51	53	27	32			158	
	25×20	51	51	27	27			155	
	30×13	99	67	60	46			425	
	30×20	99	70	60	46			423	
	30×25	99	70	60	46			421	
	40×13	107	69	50	48			558	
	40×20	107	72	60	48			544	
	40×25	107	72	60	48			538	
	40×30	107	99	60	60			538	
	50×13	102	73	50	52			658	
	50×20	102	76	50	52			658	
	50×25	102	82	50	58			645	
	50×30	102	109	50	70			630	
	50×40	102	107	50	60			625	
	60×30	127	109	63	70			1502	
	60×40	127	117	63	70			1488	
	60×50	127	112	63	60			1480	
BS 套管接頭		規格口徑	a	z			牌價		
	13	115	73				38		
	20	128	80				50		
	25	128	80				60		
(修改專用接頭)									

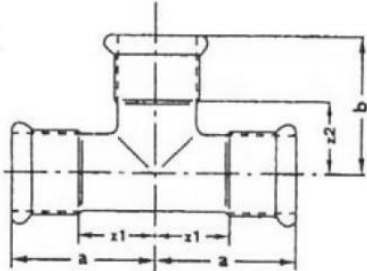
型錄圖表尺寸如有修改不另通知

3TR 異徑三通		規格口徑	a	b	y	z		牌價
		20×13	46	42	22	21		119
		25×13	51	53	27	32		158
		25×20	51	51	27	27		155
		30×13	99	67	60	46		425
		30×20	99	70	60	46		423
		30×25	99	70	60	46		421
		40×13	107	69	50	48		558
		40×20	107	72	60	48		544
		40×25	107	72	60	48		538
		40×30	107	99	60	60		538
		50×13	102	73	50	52		658
		50×20	102	76	50	52		658
		50×25	102	82	50	58		645
		50×30	102	109	50	70		630
		50×40	102	107	50	60		625
		60×30	127	109	63	70		1502
		60×40	127	117	63	70		1488
		60×50	127	112	63	60		1480
BS 套管接頭		規格口徑	a	z			牌價	
		13	115	73			38	
		20	128	80			50	
		25	128	80			60	
(修改專用接頭)								

型錄圖表尺寸如有修改不另通知

SUS304 不銹鋼有縫焊另件 10S

規 品 名 格 格	90°彎頭	45°彎頭	三通	管帽
1/2"	255	200	505	300
3/4"	255	200	505	300
1"	255	200	505	300
1 1/4"	305	275	610	350
1 1/2"	350	290	760	375
2"	450	360	960	475
2 1/2"	900	715	1615	575
3"	1150	925	2025	800
4"	1600	1280	2930	1230
5"	3000	2395	4650	1875
6"	4300	3400	6670	2575
8"	8500	6840	12300	4750
10"	16285	13825	27500	8450
12"	22900	19100	41425	12725
14"	42900	35850	57875	17575
16"	52150	39600	66450	21375

規 品 名 格 格	同心大小頭	異徑三通	規 品 名 格 格	同心大小頭	異徑三通
3/4"*1/2"	300	600	4"*3"	1225	3390
1"*3/4"	320	650	4"*2 1/2"	1375	3500
1"*1/2"	375	650	4"*2"	1490	3690
1 1/4"*1"	355	825	4"*1 1/2"	1675	3840
1 1/4"*3/4"	425	825	4"*1 1/4"	2350	5000
1 1/4"*1/2"	500	825	4"*1"	3575	5800
1 1/2"*1 1/4"	420	1000	5"*4"	2125	5360
1 1/2"*1"	475	1000	5"*3"	2325	5750
1 1/2"*3/4"	585	1175	5"*2 1/2"	3030	6250
1 1/2"*1/2"	625	1175	5"*2"	3335	7000
2"*1 1/2"	515	1215	6"*5"	2610	7500
2"*1 1/4"	655	1215	6"*4"	2930	8085
2"*1"	685	1350	6"*3"	3385	9095
2"*3/4"	725	1520	6"*2 1/2"	3850	9860
2"*1/2"	750	1520	6"*2"	4444	10700
2 1/2"*2"	655	1875	8"*6"	4700	13665
2 1/2"*1 1/2"	740	1990	8"*5"	5550	13665
2 1/2"*1 1/4"	850	2125	8"*4"	6100	13665
2 1/2"*1"	1060	2275	10"*8"	7000	32150
3"*2 1/2"	785	2325	10"*6"	7750	32150
3"*2"	910	2480	10"*5"	9300	32150
3"*1 1/2"	965	2630	12"*10"	9625	37275
3"*1 1/4"	1025	2850	12"*8"	10900	37275
3"*1"	1150	2990	12"*6"	14600	37275

SUS304 不銹鋼有縫焊另件 20S

規 品 名 格	90°彎頭	45°彎頭	三通	管帽
1/2"	280	280	595	355
3/4"	280	280	595	355
1"	280	280	595	355
1 1/4"	335	280	740	380
1 1/2"	425	325	915	400
2"	675	575	1300	530
2 1/2"	1225	1175	1985	610
3"	1600	1525	2750	940
4"	2425	1825	4075	1550
5"	4450	3575	6250	2450
6"	6650	5325	9875	3675
8"	14675	11715	20570	6510
10"	24350	19350	51425	10795
12"	32650	25975	68850	15300
14"	73000	57975	94665	24480
16"	94950	76300	97530	29490

規 品 名 格	同心大小頭	異徑三通	規 品 名 格	同心大小頭	異徑三通
3/4"*1/2"	325	660	4"*3"	1450	4500
1"*3/4"	345	770	4"*2 1/2"	1530	4675
1"*1/2"	385	770	4"*2"	1645	4325
1 1/4"*1"	350	970	4"*1 1/2"	1870	4850
1 1/4"*3/4"	460	970	4"*1 1/4"	2180	5325
1 1/4"*1/2"	520	970	4"*1"	3400	7100
1 1/2"*1 1/4"	405	1225	5"*4"	2325	7875
1 1/2"*1"	490	1225	5"*3"	2960	8375
1 1/2"*3/4"	575	1370	5"*2 1/2"	3350	8635
1 1/2"*1/2"	630	1370	5"*2"	3850	8925
2"*1 1/2"	580	1650	6"*5"	3600	11050
2"*1 1/4"	695	1650	6"*4"	4200	11575
2"*1"	725	1800	6"*3"	4375	12750
2"*3/4"	755	1980	6"*2 1/2"	5165	13280
2"*1/2"	785	1980	6"*2"	6075	14755
2 1/2"*2"	755	2285	8"*6"	7200	25715
2 1/2"*1 1/2"	870	2400	8"*5"	8100	25715
2 1/2"*1 1/4"	985	2570	8"*4"	9180	25715
2 1/2"*1"	1160	2715	10"*8"	10085	47230
3"*2 1/2"	935	3320	10"*6"	11995	47230
3"*2"	1075	3200	10"*5"	14850	47230
3"*1 1/2"	1175	3370	12"*10"	14175	62175
3"*1 1/4"	1250	3540	12"*8"	15265	62175
3"*1"	1450	3655	12"*6"	17990	62175

PVC 接頭產品牌價

品名規格	牌價	備註	品名規格	牌價	備註	品名規格	牌價	備註
45°L 給水接頭			T 型(正 T)給水接頭			異徑 T 型給水接頭		
OL 1 1/2" × 45°	17		OT 3/8"	5.0		OT 1 1/2" × 1 1/4"	25	
OL 2" × 45°	27		OT 1/2"	6.0		OT 2" × 3/8"	32	
OL 2 1/2" × 45°	37		OT 3/4"	7.5		OT 2" × 1/2"	30	
OL 3" × 45°	55		WT 1" (W)	14		OT 2" × 3/4"	30	
OL 3 1/2" × 45°	86		OT 1"	12		OT 2" × 1" (W)	40	
OL 4" × 45°	115		OT 1 1/4"	18		OT 2" × 1"	33	
OL 5" × 45°	190		OT 1 1/2"	26		OT 2" × 1 1/4"	36	
OL 6" × 45°	330		OT 2"	41		OT 2" × 1 1/2"	37	
OL 8" × 45°	720		OT 2 1/2"	59		OT 2 1/2" × 1 1/2"	47	
OL 10" × 45°	1,800		OT 3"	90		OT 2 1/2" × 2"	54	
			OT 3 1/2"	160		OT 3" × 3/4"	55	
			OT 4"	175		OT 3" × 1"	56	
90°L 給水接頭			OT 5"	270		OT 3" × 1 1/2"	65	
OL 3/8" × 90°	4.0		OT 6"	480		OT 3" × 2"	80	
OL 1/2" × 90°	5.0		OT 8"	1,600		OT 3" × 2 1/2"	88	
OL 3/4" × 90°	5.5		OT 10"	3,000		OT 4" × 1 1/2"	120	
OL 1" W × 90°	10					OT 4" × 2"	125	
OL 1" × 90°	9.0					OT 4" × 3"	150	
OL 1 1/4" × 90°	14		異徑 T 型給水接頭			OT 5" × 3"	210	
OL 1 1/2" × 90°	19		OT 1/2" × 3/8"	9.0		OT 5" × 4"	250	
OL 2" × 90°	31		OT 3/4" × 3/8"	9.0		OT 6" × 3"	310	
OL 2 1/2" × 90°	45		OT 1" (W) × 1/2"	7.5		OT 6" × 4"	360	
OL 3" × 90°	70		OT 1" (W) × 3/4"	14		OT 6" × 5"	470	
OL 3 1/2" × 90°	107		OT 1" × 3/8"	14		OT 8" × 4"	950	
OL 4" × 90°	140		OT 1" × 1/2"	14		OT 8" × 6"	1,100	
OL 5" × 90°	208		OT 1" × 3/4"	10				
OL 6" × 90°	384		OT 1 1/4" × 3/8"	10				
OL 8" × 90°	740		OT 1 1/4" × 1/2"	18				
OL 10" × 90°	2,300		OT 1 1/4" × 3/4"	14				
			OT 1 1/4" × 1"	14				
			OT 1 1/2" × 1"	16		T 型(正 T)活套式給水接頭		
			OT 1 1/2" × 3/8"	25		活套 OT3"	300	
90°L 型活套式給水接頭			OT 1 1/2" × 1/2"	20		活套 OT6"	1,050	
活套 OL3" × 90°	208		OT 1 1/2" × 3/4"	22				
活套 OL8" × 90°	1,430		OT 1 1/2" × 1(W)	25				
			OT 1 1/2" × 1"	22				

PVC 接頭產品牌價

品名規格	牌價	備註	品名規格	牌價	備註	品名規格	牌價	備註
S(直)型異徑接頭			龍頭(口)T 型接頭			清除 (潔)口接頭		
OS 4" × 2"	85		龍頭 T 型 3/4" × 1/2" 入銅	22		清除短管 2"	25	
OS 4" × 3"	100		龍頭 T 型 3/8" O	6.0		清除短管 3"	60	
OS 5" × 4"	145		龍頭 T 型 1/2" O	7.0		清除短管 4"	100	
OS 6" × 3"	210		龍頭 T 型 3/4" O	9.0		清除短管 5"	180	
OS 6" × 4"	240		龍頭 T 型 3/4" × 1/2" O	8.0		清除短管 6"	240	
OS 6" × 5"	260		龍頭(牙口)S 型(直)接頭			清除短管 8"	600	
OS 8" × 4"	600		龍頭 S 型 1/2" O 入銅	20				
OS 8" × 5"	600		龍頭 S 型 3/4" O 入銅	25				
OS 8" × 6"	600		龍頭 S 型 3/8" O	5.0		分水鞍接頭		
OS 10" × 8"	1,300		龍頭 S 型 1/2" O	5.0		分水鞍 2" × 1/2"	270	
			龍頭 S 型 3/4" O	6.0		分水鞍 2" × 3/4"	290	
			由令接頭			分水鞍 2" × 1"	300	
止閥接頭			由令 1/2" W	4.0		分水鞍 2" × 1" (W)	320	
止閥 3/8"	4.0		由令 3/4" W	6.0		分水鞍 3" × 1/2"	320	
止閥 1/2"	4.0		由令 1" W	8.0		分水鞍 3" × 3/4"	320	
止閥 3/4"	4.5		由令 1 1/4" W	10		分水鞍 3" × 1"	320	
止閥 1" (W)	7.0		由令 1 1/2" W	16		分水鞍 3" × 1" (W)	350	
止閥 1" O	7.0		由令 2" W	24		分水鞍 4" × 1/2"	320	
止閥 1 1/4" O	10		塞口(管帽)			分水鞍 4" × 3/4"	320	
止閥 1 1/2" O	13		塞口 3/8" O	3.5		分水鞍 4" × 1"	350	
止閥 2" O	19		塞口 1/2" O	3.5		分水鞍 4" × 1" (W)	350	
止閥 2 1/2" O	28		塞口 3/4" O	4.0				
止閥 3" O	38		塞口 1" (W)	6.0		法蘭接頭		
止閥 4" O	75		塞口 1" O	6.0		法蘭接頭 1 1/2"	95	
止閥 5" O	160		塞口 1 1/4" O	7.0		法蘭接頭 2"	110	
止閥 6" O	300		塞口 1 1/2" O	11		法蘭接頭 2 1/2"	130	
			塞口 2" O	17		法蘭接頭 3"	135	
龍頭(口)L 型 彎頭			塞口 2 1/2" O	27		法蘭接頭 4"	210	
龍頭 L 型 1/2" 入銅	19		塞口 3" O	39		法蘭接頭 5"	280	
龍頭 L 型 3/4" 入銅	25		塞口 3 1/2" O	60		法蘭接頭 6"	410	
龍頭 L 型 3/8"	5.0		塞口 4" O	93		法蘭接頭 8"	720	
龍頭 L 型 1/2"	5.5		塞口 5" O	133		法蘭接頭 10"	1,600	
龍頭 L 型 3/4"	7.0		塞口 6" O	216		法蘭接頭 12"	3,000	
龍頭(口)T 型 三通			塞口 8" O	410				
龍頭 T 型 1/2" 入銅	20							
龍頭 T 型 3/4" 入銅	28							

PVC 接頭產品牌價

給水用(厚)

單位：元/PC

品名規格	牌價	備註	品名規格	牌價	備註	品名規格	牌價	備註
順 T 型給水接頭			Y 型(正斜 T)給水接頭			S 型(直)同徑接頭		
O 順 T 1 1/2"	38		OY 1 1/2"	44		OS 2"	23	
O 順 T 2"	52		OY 2"	58		OS 2 1/2"	32	
O 順 T 2 1/2"	70		OY 3"	115		OS 3"	54	
O 順 T 3"	115		OY 4"	215		OS 3 1/2"	68	
O 順 T 4"	230		OY 5"	385		OS 4"	110	
O 順 T 5"	400		OY 6"	630		OS 5"	145	
O 順 T 6"	530		OY 8"	1,350		OS 6"	330	
O 順 T 8"	1,200					OS 8"	700	
						OS 10"	500	
			異徑 Y 型(斜 T)接頭					
異徑順 T 型給水接頭			OY 2" × 1 1/2"	58				
O 順 T 2" × 1 1/2"	44		OY 3" × 2"	85		S 型(直)異徑接頭		
O 順 T 3" × 2"	85		OY 4" × 2"	140		OS 1/2" × 3/8"	5.0	
O 順 T 4" × 2"	140		OY 4" × 3"	175		OS 3/4" × 3/8"	5.0	
O 順 T 4" × 3"	180		OY 5" × 2"	270		OS 3/4" × 1/2"	5.0	
O 順 T 5" × 3"	260		OY 5" × 3"	300		WS 1" (W) × 3/4"	8.0	
O 順 T 5" × 4"	350		OY 5" × 4"	340		OS 1" × 1/2"	7.0	
O 順 T 6" × 2"	370		OY 6" × 2"	370		OS 1" × 3/4"	7.0	
O 順 T 6" × 3"	400		OY 6" × 3"	400		OS 1 1/4" × 1/2"	9.0	
O 順 T 6" × 4"	420		OY 6" × 4"	440		OS 1 1/4" × 3/4"	11	
O 順 T 6" × 5"	500		OY 6" × 5"	550		OS 1 1/4" × 1"	11	
O 順 T 8" × 2"	850		OY 8" × 2"	800		OS 1 1/2" × 1/2"	12	
O 順 T 8" × 3"	890		OY 8" × 3"	860		OS 1 1/2" × 3/4"	14	
O 順 T 8" × 4"	960		OY 8" × 4"	930		OS 1 1/2" × 1"	14	
O 順 T 8" × 6"	1,150		OY 8" × 6"	1,250		OS 1 1/2" × 1 1/4"	14	
O 順 T 10" × 6"	2,400		OY 10" × 6"	2,500		OS 2" × 1/2"	18	
						OS 2" × 3/4"	18	
						OS 2" × 1	20	
			S (直)型同徑接頭			OS 2" × 1 1/4"	20	
			OS 3/8"	4.0		OS 2" × 1 1/2"	22	
			OS 1/2"	4.5		OS 2 1/2" × 1 1/2"	28	
			OS 3/4"	5.0		OS 2 1/2" × 2"	32	
			OS 1"	7.0		OS 3" × 1 1/2"	40	
			WS 1" (W)	8.0		OS 3" × 2"	40	
			OS 1 1/4"	11		OS 3" × 2 1/2"	44	
			WS 1 1/2"	16		OT 4" × 1 1/2"	70	

不銹鋼軟管製品

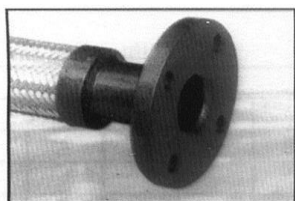

固定法蘭(FF型)

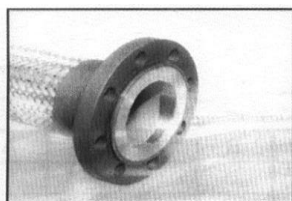

活動法蘭(RF型)



端焊型(P型)



立布型(SM型)

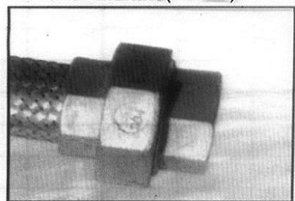

由任型(U型304)

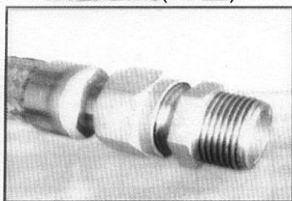

母套(附立布)(SN型304
附立布)

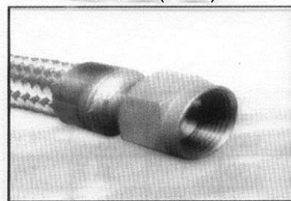

母套(SN型304)

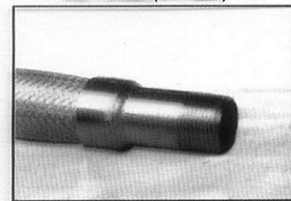

管牙(PT型304)

口徑	不銹鋼軟管 SUS304 100m/m 單價		法蘭一端單價(JIS 10K)				由任一端單價			SN 一端單價		立布一端單價		SM 型一端單價	
			破鋼	活動式 襯套 SUS304	全條 SUS304		鑄鐵	鍛鋼	白鐵 SUS304	鐵	白鐵 SUS304	鐵	白鐵 SUS304	鐵	白鐵 SUS304
	固定式	固定型			活動式										
B	螺旋型	亞米茄型													
3/8"	40		115	180	275	320	80	160	260	60	125	30	90	70	120
1/2"	30		115	180	275	320	80	160	260	60	135	40	120	70	140
3/4"	40	80	140	190	325	360	110	230	350	100	245	60	200	100	250
1"	50	125	170	260	435	510	160	310	460	110	310	70	250	110	320
1 1/4"	70	150	215	350	555	640	190	410	720	190	700	110	660	180	750
1 1/2"	80	180	255	380	595	690	260	480	900	250	950	170	900	240	1,000
2"	110	230	280	470	725	870	330	670	1,300	400	1,500	350	1,350	380	1,400
2 1/2"	180	260	380	610	975	1,160	550	1,200	2,800					450	
3"	200	300	425	730	1,025	1,270	770	1,780	3,800					500	
4"	250	350	555	900	1,245	1,550	1,370	2,800	5,400						
5"		490	820	1,400	2,000	2,450									
6"		600	980	1,900	2,400	3,300									
8"		1,075	1,400	2,800	3,200	4,500									
10"		1,480	2,300	4,000	4,500	6,300									

合成橡膠防震接頭

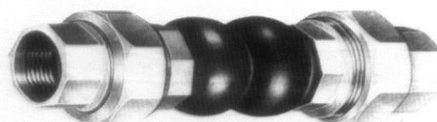
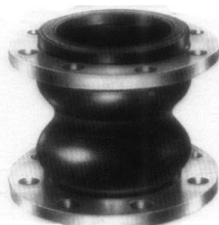
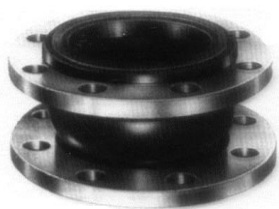

規格 型式	型號	工作 壓力	口徑													
			1/2"	3/4"	1"	1 1/4"	1 1/2"	2"	2 1/2"	3"	4"	5"	6"	8"	10"	12"
單球式 (法蘭口)	100	JIS-10Kg				1170	1170	1230	1470	1620	2190	2940	4020	5520	8280	10440
雙球式 (法蘭口)	200	JIS-10Kg				1760	1760	1880	2560	3000	4080	5280	6560	10200	14000	17840
由任式 (牙口)	20U	JIS-10Kg	800	800	880	1120	1320	1680	3320	4720						

不銹鋼軟管

()%

	不銹鋼防震(避震、減震、撓性)軟管、接頭				不銹鋼伸縮(膨脹)接頭				
圖示									
型號 Model NO.	500T	500	500H	600	250STG	150SG	400SG	1000H	800
結構特徵	外牙式	流體接觸面全 SUS-304			網狀	附內筒	附內筒	附內筒	二節式
工作壓力	20 Kg/cm ²	10 Kg/cm ²	20 Kg/cm ²	10 Kg/cm ²	10 Kg/cm ²		20 Kg/cm ²		20 Kg/cm ²
接頭材質	全 SUS-304	法蘭 FCD-40	法蘭 FCD-40	法蘭 SS-41	全 SUS-304	法蘭 SS-41	法蘭 SS-41-JIS-20Kg		法蘭 SS-41
1/2"	450			780	2320		2900		
3/4"	530			780	2320		2900		
1"	660			970	2440		3350		
1 1/4"	880			1280	2620		4000		
1 1/2"	1160	1170	1170	1620	2760	2130	4500	5520	5520
2"	1380	1380	1700	2100	3050	2380	4800	6100	6100
2 1/2"	2250	1630	2000	2690	3950	2880	5800	7350	7350
3"	3130	1780	2300	3050	4500	3380	6980	8870	8870
4"		2130	3100	3780		4000	8720	10700	10700
5"		2950	4000	5820		5250	11340	14100	14200
6"		3750	5130	7650		6500	13960	17450	18320
8"		6270	8600	13160		10360	21800	26200	26900
10"		8180	12700	21380		14450	30500	35630	36650
12"		10360	15400	29380		18550	40700	46980	48290
14"		27300	46900						



盒接頭(Box Connector)

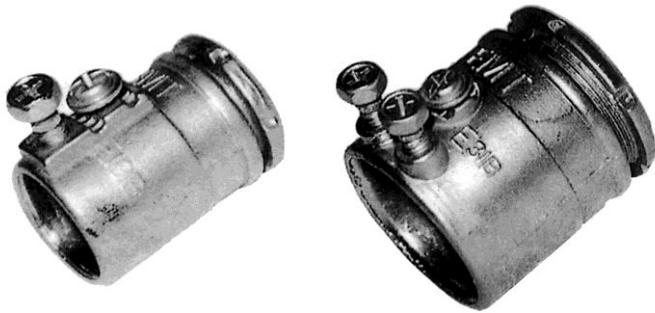

規格	型號	定價 (元/組)	備註
1/2"	E-19B	17	
3/4"	E-25B	23	
1"	E-31B	36	
1 1/4"	E-39B	60	
1 1/2"	E-51B	100	
2"	E-63B	150	
2 1/2"	E-75B	200	

管接頭(Coupling)



規格	型號	定價 (元/組)	備註
1/2"	E-19C	10	
3/4"	E-25C	13	
1"	E-31C	22	
1 1/4"	E-39C	30	
1 1/2"	E-51C	45	
2"	E-63C	72	
2 1/2"	E-75C	98	

彎管(Elbow)



規格	型號	定價 (元/組)	備註
1/2"	E-19N	77	
3/4"	E-25N	82	
1"	E-31N	88	
1 1/4"	E-39N	118	
1 1/2"	E-51N	182	
2"	E-63N	330	
2 1/2"	E-75N	470	

※另有 45° 彎管。

RSG、2606 導電線管另件

品名	尺寸									
	1/2"	3/4"	1"	1 1/4"	1 1/2"	2"	2 1/2"	3"	4"	
一般電白車牙接頭	21	28	42	56	63	98	175	210	315	
2606 車牙接頭	35	42	53	88	105	140	245	280	455	
一般電白月彎(3R)	76	78	80	100	140	226	400	656	1230	
台電月彎(6R)	100	120	140	200	320	480	1120	1200	1800	
2606 月彎(6R)	240	270	300	390	540	840	1950	2100	4000	
免車牙盒接(電白)	34	46	72	120	200	300	400	612	650	
免車牙接頭(電白)	20	26	44	60	90	144	196	304	342	

金屬軟管(電氣配管類)

單位：M

規 格 品 名	3/8"	1/2"	3/4"	1"	1 1/4"	1 1/2"	2"	2 1/2"	3"	4"
防水金屬軟管	80	80	120	160	275	315	470	900	1100	1635
鍍鋅軟管	67	70	100	140	235	270	370	635	800	1300
鋼絲裸管	實價	實價	實價	實價	實價	實價	實價	實價	實價	實價
鋼絲浪管	實價	實價	實價	實價	實價	實價	實價	實價	實價	實價
長度(捲)	50M	50M	50M	50M	30M	25M	20M	10M	10M	10M

※長度可另依需求訂製



防水金屬軟管



鍍鋅軟管



鋼絲裸管



鋼絲浪管

軟管接頭配件

單位：只

規 格 品 名		3/8"	1/2"	3/4"	1"	1 1/4"	1 1/2"	2"	2 1/2"	3"	4"
	防水 45° 盒接頭	135	155	215	335	500	625	935	-	-	-
	防水 90° 盒接頭	135	155	215	335	500	625	935	-	-	-
	防水內牙 管接頭(RSG)	70	67	87	140	195	280	370	780	1020	1670
	防水盒接頭	70	67	87	140	195	280	370	780	1020	1670
	防水管接頭 (EMT、PVC)	70	67	87	140	195	280	370	780	1020	1670
	管端護套 (牙圈、管舌)	12	14	18	25	35	50	80	150	180	230
	螺旋接頭	20	20	35	50	-	-	-	-	-	-
	鎖緊螺帽 (LN)	-	10	13	20	45	60	75	115	140	190

壓力計



直立式



埋入式



充油直立式



充油埋入式



有緣

直立式

錶徑	1 1/2"	2"	2 1/2"	3"	4"
管牙口徑	1/8"PT 牙	1/4"PT 牙	1/4"PT 牙	3/8"PT 牙	3/8"(1/2")PT 牙
壓 力 型 號	立式無緣	立式無緣	立式無緣	立式無緣	立式有緣
2KG~35KG	240	400	480	550	980

埋入式

錶徑	1 1/2"	2"	2"	2 1/2"	3"	4"
管牙口徑	1/8"PT 牙	1/4"PT 牙	1/4"PT 牙	1/4"PT 牙	3/8"PT 牙	3/8"PT 牙
壓 力 型 號	埋入式無緣	埋入式無緣	埋入式有緣	埋入式有緣	埋入式有緣	埋入式有緣
2KG~35KG	280	470	810	975	1120	1995

※另有不銹鋼外殼，歡迎來電洽詢。

充油直立式

錶徑	1 1/2"	2"	2 1/2"	3"	4"
管牙口徑	1/8"PT 牙	1/4"PT 牙	1/4"PT 牙	3/8"PT 牙	3/8"PT 牙
壓 力 型 號	立式無緣	立式無緣	立式無緣	立式無緣	立式無緣
2KG~35KG	1000	770	1440	2150	2420

充油埋入式

錶徑	1 1/2"	2"	2 1/2"	2 1/2"	3"	4"
管牙口徑	1/8"PT 牙	1/4"PT 牙	1/4"PT 牙	1/4"PT 牙	3/8"PT 牙	3/8"PT 牙
壓 力 型 號	埋入無緣	埋入無緣	埋入無緣	埋入有緣	埋入有緣	埋入有緣
2KG~35KG	1400	1400	1400	1400	3200	3200

全不銹鋼充油直立式

錶徑	1 1/2"	2"	2 1/2"	3"	4"
管牙口徑	1/8"PT 牙	1/4"PT 牙	1/4"PT 牙	3/8"PT 牙	3/8"PT 牙
壓 力 型 號	立式無緣	立式無緣	立式無緣	立式無緣	立式無緣
2KG~35KG	3000	3000	3550	3870	4195

全不銹鋼充油埋入式

錶徑	1 1/2"	2"	2"	2 1/2"	2 1/2"	3"	4"
管牙口徑	1/8"PT 牙	1/4"PT 牙	1/4"PT 牙	1/4"PT 牙	1/4"PT 牙	3/8"PT 牙	3/8"PT 牙
壓 力 型 號	埋入無緣	埋入無緣	埋入有緣	埋入無緣	埋入有緣	埋入有緣	埋入有緣
2KG~35KG	3600	3600	3600	3600	4990	5440	6400

溫度計

BL 溫度計

範圍	錶徑			
	2"	3"	4"	5"~6"
±50°C	480	480	600	1400
50°C	400		520	1300
100°C	400		520	1300
120°C	400		520	1300
150°C	400		520	1300
200°C	400		520	1300
250°C	480	480	600	1400
300°C	480	500	600	1400
400°C	520	540	620	1500
500°C	560	700	660	1600

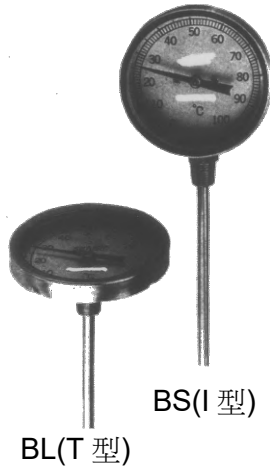

BS 溫度計

範圍	錶徑		
	3"	4"	6"
±50°C	860	1100	3000
50°C	800	1000	2800
100°C	800	1000	2800
120°C	800	1000	2800
150°C	800	1000	2800
200°C	800	1000	2800
250°C	860	1100	3000
300°C	860	1100	3200
400°C	880	1120	3200
500°C	920	1160	3400

角板型溫度計

規格		型式	
		S 型	L 型
±50°C	1/2"	440	440
0-50°C	牙	400	400
0-100°C	2"	400	400
0-120°C	長感	400	400
0-150°C	溫	400	400
0-200°C	棒	440	440

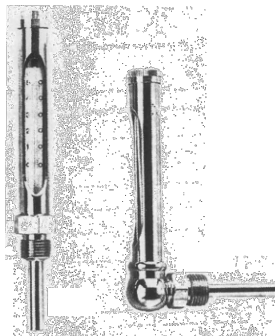

套管溫度計

規格		型式	
		S 型	L 型
±50°C	1/2"	860	960
0-50°C	牙	800	900
0-100°C	2"	800	900
0-120°C	長感	800	900
0-150°C	溫	800	900
0-200°C	棒	860	960



曲管

品名	90°曲管(U 型)		180°曲管(O 型)	
	鐵製	不銹鋼	鐵製	不銹鋼
1/4"	132	345	132	345
3/8"	132	345	132	345
1/2"	280	705	255	705

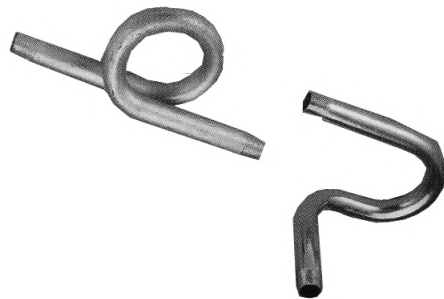

可焊接頭

尺寸	1/4"	3/8"	1/2"	3/4"	1"	1 1/4"	1 1/2"	2"	3"	4"
黑品	17	17	19	30	40	60	80	105	270	420
不銹鋼	50	50	50	76	112	174	230	280	945	1470

FLUID FILLED THERMOMETERS

TYPE
HS3
HS4
HS5
HS6



TYPE
HS4-1A, HS4-2A
HI4-1A, HI4-2A



TYPE
MW4, MW6



TYPE
MW4-1A, MW4-2A
MW6-1A, MW6-2A



TYPE
MF4-1A, MF4-2A
MF6-1A, MF6-2A



TYPE
MF4, MF6



TYPE
H04
VIBRATION RESISTANT



BI-METAL THERMOMETERS

TYPE BL
BL1.5, BL2, BL2.5
BL3, BL4, BL5, BL6



TYPE
BS2.5
BS3, BS4
BS5, BS6



TYPE
BA3
BA4
BA5



RECORDING INSTRUMENTS

TYPE
BC-1



TYPE
BC-2



GLASS THERMOMETERS

TYPE
CL
CS



TYPE
GL
GS



C 型鋼、角鐵、U型槽鐵、牙條

單位：3M/支

C 型鋼 尺寸	鍍鋅無孔	鍍鋅沖孔 (3/8 孔)	不銹鋼無孔	不銹鋼沖孔 (3/8 孔)
25X41X1.2	380	400	1770	1800
25X41X1.6	490	510	2170	1940
25X41X2.0	1075	695		
41X41X1.6(高腳)	655	670	2535	2485
41X41X2.0(高腳)	825	825	3600	
41X41X2.6(高腳)	1250	1345	-	-



輕量型鋼

***A*B*C*厚度(單位：mm)			
75*45*15*2.3mm	10*50*20*2.3mm	125*50*20*2.3mm	150*65*20*2.3mm



鍍鋅 單位：3M/支						不銹鋼 單位：3M/支				
角鐵 尺寸	無孔	單孔 (3/8)	單孔 (1/2)	雙孔 (3/8)	雙孔 (1/2)	角鐵 尺寸	無孔	單孔 (3/8)	單孔 (1/2)	雙孔
2"x3.5mm	835	775	810	790	830	2"x2.7mm	2370	2500	2535	2570
2"x5.0mm	1120	-	1150	-	1185	以上未列之尺寸規格歡迎來電詢價				
2"x6.0mm	1450	-	1520	-	1585					
2 1/2"x5.0mm	1660	1428	1525	-	1590					
3"x6.0mm	2335	-	2370	-	2435					

單位：3M/支

鍍鋅U型槽鐵 尺寸	無孔	單孔	雙孔	中孔
3"	2050	2120	2185	
4"	2735	2800	2870	
5"	4260			
6"	5870			



單位：3M/支

尺寸 材質	3/8"	1/2"	5/8"	3/4"
鍍鋅	108	246	520	740
不銹鋼	760	1370	2550	3670



***以上產品可做熱浸鍍鋅、不定尺歡迎來電詢價訂購

鍍鋅 U 型螺絲

線徑 管徑	1/4"	1/4"加長	5/16"	3/8"	3/8"加長	1/2"	1/2"加長
1/2"	12	17.5	18	17.5	28		
3/4"	12.5	18	18.5	18.5	28	22.5	
1"	13.5	20	21	20.5	29	27	
1 1/4"	16	23	25	23.5	34		
1 1/2"	17.5	25	26	25	36.5	94	
2"	18.5	28	31	29	41.5	90	104
2 1/2"	25	34	34	34	46.5	95	125
3"	28	38	40	38	52.5	100	130
4"	32.5	48.5	48.5	43.5	65	107.5	160
5"				60	81	125	190
6"				70	95	50	195
8"				97.5	150	187.5	250
10"				142.5	190	250	325
12"				250	310	320	395
14"						420	680









不銹鋼 U 型螺絲

線徑 管徑	1/4"	1/4"加長	5/16"	5/16"加長	3/8"	3/8"加長	1/2"	1/2"加長
1/2"	32	49	47	77	65	107		
3/4"	34	51	51	80	67	113.5		
1"	37.5	56	57.5	87	80	120		
1 1/4"	45	67	73.5	100	97	140		
1 1/2"	47	70	77	117	103.5	147		
2"	57.5	77	90	123.5	113.5	180	293.5	
2 1/2"	69	87	107	150	143.5	187	333.5	440
3"	80	107	130		156.7	213.5	360	487
4"	100	127	150		187	253.5	420	573.5
5"					223.5	307	473.5	653.5
6"					273.5	373.5	567	800
8"					367	473.5	740	1027
10"					547	667	960	1273.5
12"					707	827	1180	1473.5
14"							1407	1873.5

壁 虎

品 名 牙 徑	內牙壁虎 (膨脹螺絲)		內迫式壁虎		品 名 牙 徑	外牙壁虎 (套管式)		平頭式壁虎	
	鐵	不銹鋼	鐵	不銹鋼		鐵	不銹鋼	鐵	不銹鋼
1/4"	7.2	48	6.4	57.6	1/4"*2"	4	15.2	4.8	18
5/16"	8	52	6.8	64.8	5/16"*2 1/2"	5	18.4	5.6	21.2
3/8"*12.7mm	7.6	56	7.6	68.4	3/8"*2 1/2"	8.4	32.5	9.2	45.2
3/8"*14.2mm	8	-	-	-	3/8"*3"	10	39.6	12	52
1/2"	18.4	120	16	144	1/2"*3"	16.4	64	22	76
5/8"	40	280	36	345.6	1/2"*4"	21.4	86.4	32	120

懸吊系列

管徑								
	不銹鋼護管夾	雙層管束	葫蘆管束 3/8"孔	葫蘆管束 1/2"孔	不銹鋼葫蘆束 3/8"孔	不銹鋼葫蘆束 1/2"孔	P 型管夾 (附螺絲)	不銹鋼 P 型管夾 (附螺絲)
1/2"	4	38.5	12	14.5	50	63.5	14.5	59
3/4"	6.9	41.5	12.5	15	53.5	67	15.5	64
1"	9.6	50	13	15.5	57	70	16.5	70
1 1/4"	13.7	54.5	20	22.5	87	100	19	74
1 1/2"	18.8	57	20.5	23	93.5	107	19.5	77
2"	22.5	67	23	25.5	100	113.5	33.5	123
2 1/2"	25.7	147	31	33.5	120	133.5	37	137
3"	33.5	160.5	36	38.5	140	153.5	40	160
4"	48.8	237.5	47.5	50	187	207	60	247
5"	233.3	345	65	67.5	247	267	75	327
6"	306.7	400	82.5	85	293.5	307	91.5	373
8"	-	850	131.5	134	427	440	195	650

										
可調型管夾		子母型管束		單立管束		萬向吊架			虎口夾	
1/2"	24.5	1/2"*1"	33.5	19mm	5	萬向吊架	3/8"(組)	117.5	1/2"(夾片)	10.5
1"	27.5	1/2"*1 1/4"	37	22mm	6	萬向吊架	1/2"(組)	122.5	3/4"(夾片)	11
		1/2"*1 1/2"	37	25mm	6.5	萬向吊架	3/8"(組)	126	1"(夾片)	13
		1/2"*2"	40.5	31mm	8	開口 36mm			上部	27.2
						萬向吊架	1/2"(組)	132.5	上部(大)	72.2
						開口 36mm			鑄鐵 3/8"	195
						萬向吊架上部	3/8"	77.5	鑄鐵 1/2"	250
						開口 25mm			鑄鐵 5/8"	178
						萬向吊架上部	1/2"	82.5		
						開口 25mm				
						萬向吊架上部	3/8"	92.5		
						開口 36mm				
						萬向吊架上部	1/2"	97.5		
						開口 36mm				

孔徑									
	簡易吊架	彈簧螺母	型鋼華司	牙條接頭	楔型 螺母/螺絲	預埋螺絲 (模板)	預埋螺絲 (鋼骨)	雙立管束	雙層線 槽管束
3/8"	40	27.8	5.6	10	16.7	19	32.5	詢價	詢價
1/2"	40	30.6	5.6	22.5		46	52.5	詢價	詢價

電鍍六角螺絲(全牙)

單位：只

徑長	1/2"	5/8"	3/4"	1"	1 1/4"	1 1/2"	1 3/4"	2"	2 1/2"	3"
1/4"	0.78	0.7	0.78	0.9	1.04	1.17	1.2	1.41	1.7	2.02
5/16"	1.14	1.1	1.19	1.41	1.5	1.84	1.9	2.24	2.64	3.09
3/8"	1.8	1.7	1.8	2.13	2.38	2.69	2.98	3.28	3.89	4.49
7/16"			3.1	3.1	3.3	3.7	4.1	4.5	5.4	6.1
1/2"			4.25	4.25	4.69	5.24	5.8	6.34	7.45	8.5
5/8"				7.55	8.09	9.1	9.91	10.85	12.58	14.3
3/4"						15.39	16.69	18.26	20.6	23.21

電鍍六角螺絲(半牙)

徑長	2"	2 1/2"	3"	3 1/2"	4"	4 1/2"	5"	5 1/2"	6"	6 1/2"
1/4"				3.3	3.06	4	3.74	5.2	6.5	
5/16"				4.8	5.4	6.1	6.7	7.3	9.8	
3/8"	4.2	4.7	5.7	6.29	7.14	7.82	8.67	9.35	10.37	10.6
7/16"										
1/2"	8.3	9	9.9	11.56	12.92	14.28	15.81	16.83	18.19	19.72
5/8"	12.7	14.2	16.1	19.04	20.91	22.95	25.16	27.37	29.58	32.13
3/4"	21.3	23	26.1	31.11	24.17	38.42	39.61	43.32	55	59.8

不銹鋼六角頭機械螺絲

徑長	1/2"	3/4"	1"	1 1/4"	1 1/2"	2"	2 1/2"	3"	3 1/2"	4"	4 1/2"	5"	5 1/2"	6"
3/16"														
1/4"	2.1	3.2	3.8	4.3	4.7	6	7.2	8.1	7.9	8.9	11.6	12.7	16.6	17.1
5/16"	3.5	5.4	6.4	7.2	8.1	10	11.8	13.6	15.6	15	18.4	20.5	25.7	26
3/8"	6.7	8	9.1	10.5	11.9	15.1	17.5	20.7	23.5	26.1	31.8	35.3	38.5	44
7/16"	-	10.1	11.7	13.2	14.9	18.0	20.8	25.7	31.9	35.7	-	-	-	-
1/2"	-	17.3	19.6	22	24.3	29	34.6	40	44.6	50	57.8	66.8	70.7	80
5/8"	-	-	33.4	36	40.5	47.6	55.6	63	70.7	78.7	94.2	104	114	124
3/4"	-	-	-	-	66	77	88.4	100	112	122	152	166	181	205
7/8"	-	-	-	-	96.7	140	155	181	200	227	250	265	288	312
1"	-	-	-	-	-	159.3	181.2	250	230.8	310	332	364	400	430

鍍鋅華司、鍍鋅螺帽、鍍鋅突緣螺帽、SUS 華司、SUS 螺帽

品名 孔徑	鍍鋅華司	鍍鋅螺帽	鍍鋅突緣螺帽	SUS 華司	SUS 螺帽	SUS 突緣螺帽
	單價(PC)	單價(PC)	單價(PC)	單價(PC)	單價(PC)	單價(PC)
1/4"	0.77	0.3	0.51	0.6	0.9	3
1/4"(大)	-	-	0.77	-	-	9.6
5/16"	0.88	0.54	0.77	0.8	1.9	4.2
3/8"	0.9	0.75	1.02	1.3	3.1	6
3/8"(大)	-	-	1.6	-	-	15.4
1/2"	2.72	1.71	2.56	1.7	7.2	16.6
5/8"	3.06	3.25	8.8	3.4	13.8	-
3/4"	4.76	5	-	6	20.4	-
7/8"	5.44	10.97	-	10.9	40	-
1"	7.15	17.97	-	15.3	70	-

迫緊墊片

單位：PC

規格 品名	1/2"	3/4"	1"	1 1/4"	1 1/2"	2"	2 1/2"	3"	4"	5"	6"	8"	10"	12"	14"
橡膠 5K FF	9	12	13	15	16	18	20	23	25	45	48	68	93	138	188
橡膠 5K RF	5	8	10	10	13	15	18	23	28	38	43	65	80	90	123
橡膠 10K,PN16 FF	9	12	13	15	16	18	20	23	25	45	48	68	93	138	188
橡膠 10K, RF	5	8	9	10	11	15	18	22	23	34	40	59	80	90	125
橡膠 150P FF	9	12	13	15	16	18	20	23	25	45	48	59	93	124	169
橡膠 150P RF	5	7	9	9	11	15	18	22	23	25	34	38	59	72	81
橡膠 20K, FF	9	12	13	15	16	18	20	23	25	45	48	68	105	138	188
橡膠 20K, RF	6	8	11	11	14	17	19	25	30	41	47	72	88	99	135
A163 非石棉 5K FF	23	25	33	50	53	63	88	118	153	213	270	413	708	793	900
A163 非石棉 5K RF	10	13	18	23	28	53	50	78	95	130	190	270	413	618	713
A163 非石棉 10K,PN10 FF	30	38	60	63	73	90	113	125	163	275	333	495	720	788	825
A163 非石棉 10K,PN10 RF	13	15	20	25	30	40	53	65	95	138	183	263	450	680	738
A163 非石棉 150P FF	30	35	45	53	63	95	125	150	205	288	338	495	750	900	
A163 非石棉 150P RF	13	15	20	25	28	40	55	65	113	150	200	320	495	738	863
A163 非石棉 20K,PN16 FF	30	38	60	63	73	90	115	163	200	288	438	513	830	875	
A163 非石棉 20K,PN16 RF	13	15	20	25	30	40	53	75	110	163	220	318	500	750	900
EPDM 5K FF	25	28	33	53	53	60	98	110	145	190	225	413	558	618	
EPDM 5K RF	10	10	15	18	18	28	40	48	60	88	125	205	375	420	472
EPDM 10K, FF	18	18	28	40	40	88	118	125	163	215	238	420	625	698	
EPDM 10K, RF	10	15	18	20	20	33	45	55	75	113	138	218	380	420	488
EPDM 20K, FF	36	39	58	69	74	100	129	138	179	237	261	462	688	767	
EPDM 20K, RF	11	17	19	22	22	36	50	61	83	124	151	239	418	462	536
橡膠 由任皮	1.5	1.8	2.8	3.3	3.8	4.3	5.8	7.4	15.9						
石棉 由任皮	3	4	5	7	8	10	13	13	16						

防蝕膠帶

尺寸 品名	2" (15M/捲)	4" (15M/捲)	6" (15M/捲)	8" (15M/捲)	12" (15M/捲)	防蝕底劑	防蝕膏
PE 冷包型(1.0mm)	270	625	950	1190	實價	3 公升/桶	3 公斤/包
熱融型(2.0mm)	330	660	990	1290	實價	200	330

五金另料

產品名稱	單位	單價	產品名稱	單位	單價
焊條 2.6	KG	116	缺氧膠(大)	罐	650
焊條 3.2	KG	110	紅油漆	加侖	795
ST 焊條 2.6	KG	460	紅丹漆	加侖	635
ST 焊條 3.2	KG	450	松香水	加侖	265
AB 膠	組	500	車牙油	加侖	520
止洩帶	條	100	發泡劑 500ml	罐	170
手套	打	75	發泡劑 750ml	罐	215
噴漆	罐	85	瓦斯	罐	30
			瑯瑯膠	組	400

產品名稱	單位	單價
砂輪片 4"(6mm)	PC	35
砂輪片 12"	PC	110
砂輪片 14"	PC	126
砂輪片 16"	PC	146
切片(1.0mm)	PC	14
切片(2.0mm)	PC	16

物理特性 (Tensile Requirements) :

ASTM A500

圓管 (Round Structural Tubing)			
	Grade A	Grade B	Grade C
抗拉強度 (T.S) psi (Mpa)	45 000(310)	58 000(400)	62 000(427)
降伏強度 (Y.S) psi (Mpa)	33 000(228)	42 000(290)	46 000(317)
伸長率 (Elongation) %	25	23	21
方形管 (Shaped Structural Tubing)			
	Grade A	Grade B	Grade C
抗拉強度 (T.S) psi (Mpa)	45 000(310)	58 000(400)	62 000(427)
降伏強度 (Y.S) psi (Mpa)	39 000(269)	46 000(317)	50 000(345)
伸長率 (Elongation) %	25	23	21

CNS 4435/JIS G3444

圓管 (Round Structural Tubing)				
	STK 400	STK 490	STK 500	STK 540
抗拉強度 (T.S) N/mm ² (kgf/mm ²)	400(41)	490(50)	500(51)	540(55)
降伏強度 (Y.S) N/mm ² (kgf/mm ²)	235(24)	315(32)	355(36)	390(40)
伸長率 (Elongation) %	縱向	23	23	15
	橫向	18	18	10

CNS 7141/JIS G3466

方形管 (Shaped Structural Tubing)		
	STKR 400	STKR 490
抗拉強度 (T.S) N/mm ² (kgf/mm ²)	400(41)	490(50)
降伏強度 (Y.S) N/mm ² (kgf/mm ²)	245(25)	325(33)
伸長率 (Elongation) %	23	23

尺寸許可差 (Dimensional tolerances) :

	圓管 (Circular)	方矩形管 (Square/Rectangular)
外徑/邊長	≤50mm ±0.5mm >50mm ±1.0 %	≤100mm ±1.5mm >100mm ±1.5 %
平坦度	-	≤100mm 0.5mm ↓ >100mm 0.5 % ↓
直角度	-	90° ±1.5°
角隅之尺度 (S)	-	3 * t (板厚)
長度	+50mm -0 mm	+50mm -0 mm
厚度	≤4mm +0.6mm -0.5mm >4mm +15% -12.5%	≤3mm ±0.3mm >3mm ±10 %
直度 (彎曲度)	-	全長度M*0.3% ↓
扭度	-	≤100mm 全長度M*1.4mm ↓ >100mm 全長度M*2.4mm ↓
真圓度	1 %	-

矩形管尺寸規格

規格	厚度	單位重	截面積	剖面慣性矩 cm^4		剖面迴轉半徑 cm		剖面係數 cm^3		塑性剖面係數 cm^3	
				lx	ly	ixx	iyy	Zx	Zy	Zpx	Zpy
A * B (mm)	mm	kg/m	cm ²								
60 x 30	2.3	3.12	3.792	16.8	5.65	2.11	1.22	5.61	3.76	7.11	4.37
	3.2	4.27	5.087	21.4	7.08	2.05	1.18	7.15	4.72	9.27	5.66
75 x 45	2.3	4.20	5.172	38.9	17.6	2.74	1.84	10.4	7.82	12.7	8.94
	3.2	5.78	7.007	50.8	22.8	2.69	1.80	13.5	10.1	16.9	11.8
80 x 40	2.3	4.20	5.172	42.1	14.3	2.85	1.66	10.5	7.14	13.1	8.11
	3.2	5.78	7.007	54.9	18.4	2.80	1.62	13.7	9.21	17.5	10.7
100 x 50	2.3	5.29	6.552	84.8	29.0	3.60	2.10	17.0	11.6	21.0	13.0
	3.2	7.28	8.927	112	38.0	3.55	2.06	22.5	15.2	28.2	17.4
	4.5	10.10	12.17	147	48.9	3.47	2.00	29.3	19.5	37.6	23.0
125 x 75	3.2	9.80	12.13	257	117	4.60	3.10	41.1	31.1	50.1	35.3
	4.0	12.16	14.95	311	141	4.56	3.07	49.7	37.5	61.1	43.0
	4.5	13.63	16.67	342	155	4.53	3.04	54.8	41.2	67.7	47.5
	6.0	17.95	21.63	428	192	4.45	2.98	68.5	51.1	86.2	60.3
150 x 75	3.2	11.05	13.73	402	137	5.41	3.16	53.6	36.6	66.3	41.0
	4.5	15.40	18.92	539	183	5.34	3.11	71.9	48.7	90.0	55.5
	6.0	20.31	24.63	679	228	5.25	3.04	90.5	60.7	115	70.6
150 x 100	3.2	12.31	15.33	488	262	5.64	4.14	65.1	52.5	78.0	59.2
	4.5	17.16	21.17	658	352	5.58	4.08	87.7	70.4	106	80.5
	6.0	22.66	27.63	835	444	5.50	4.01	111	88.8	137	103
200 x 100	4.5	20.69	25.67	1330	455	7.20	4.21	133	90.9	165	102
	6.0	27.37	33.63	1700	577	7.12	4.14	170	115	213	132
250 x 150	6.0	36.79	45.63	3890	1770	9.23	6.23	311	236	378	266
	9.0	54.52	66.67	5480	2470	9.06	6.09	438	330	542	380
	12.0	71.80	86.53	6850	3070	8.90	5.95	548	409	689	482
300 x 200	6.0	46.21	57.63	7370	3960	11.3	8.29	491	396	588	446
	9.0	68.64	84.67	10500	5630	11.2	8.16	702	563	851	644
	12.0	90.63	110.5	13400	7110	11.0	8.02	890	711	1090	826
350 x 150	6.0	46.21	57.63	8910	2390	12.4	6.44	509	319	636	353
	9.0	68.64	84.67	12700	3370	12.3	6.31	726	449	920	507
	12.0	90.63	110.5	16100	4210	12.1	6.17	921	562	1180	648
350 x 250	6.0	55.63	69.63	12500	7460	13.4	10.3	712	597	843	671
	9.0	82.78	102.7	17900	10700	13.2	10.2	1030	857	1230	976
	12.0	109.48	134.5	23000	13700	13.1	10.1	1310	1090	1590	1260
400 x 200	9.0	82.78	102.7	21300	7270	14.4	8.42	1070	727	1320	816
	12.0	109.48	134.5	27300	9230	14.2	8.28	1360	923	1710	1050
400 x 300	9.0	96.91	120.7	28200	18200	15.3	12.3	1410	1210	1670	1370
	12.0	128.32	158.5	36300	23300	15.1	12.1	1810	1550	2170	1780
450 x 350	9.0	110	138.7	41700	28400	17.3	14.3	1850	1620	2180	1840
	12.0	147	182.5	53900	36700	17.2	14.2	2400	2100	2850	2400
	16.0	195	239.2	69000	46800	17.0	14.0	3070	2680	3680	3100

方形管尺寸規格

規格	厚度	單位重	截面積	剖面慣性矩 cm^4		剖面迴轉半徑 cm		剖面係數 cm^3		塑性剖面係數 cm^3	
				I_x	I_y	i_{xx}	i_{yy}	Z_x	Z_y	Z_{px}	Z_{py}
50 x 50	1.6	2.45	3.032	11.7	11.7	1.96	1.96	4.68	4.68	5.46	5.46
	2.0	3.04	3.737	14.1	14.1	1.95	1.95	5.66	5.66	6.66	6.66
	2.3	3.48	4.252	15.9	15.9	1.93	1.93	6.34	6.34	7.52	7.52
	3.2	4.77	5.727	20.4	20.4	1.89	1.89	8.16	8.16	9.89	9.89
60 x 60	2.3	4.20	5.172	28.3	28.3	2.34	2.34	9.44	9.44	11.1	11.1
	3.2	5.78	7.007	36.9	36.9	2.30	2.30	12.3	12.3	14.7	14.7
75 x 75	2.3	5.29	6.552	57.1	57.1	2.95	2.95	15.2	15.2	17.7	17.7
	3.2	7.28	8.927	75.5	75.5	2.91	2.91	20.1	20.1	23.8	23.8
80 x 80	2.3	5.65	7.012	69.9	69.9	3.16	3.16	17.5	17.5	20.3	20.3
	3.2	7.79	9.567	92.7	92.7	3.11	3.11	23.2	23.2	27.3	27.3
100 x 100	2.3	7.09	8.852	140	140	3.97	3.97	27.9	27.9	32.3	32.3
	3.2	9.80	12.130	187	187	3.93	3.93	37.5	37.5	43.7	43.7
	4.0	12.16	14.950	226	226	3.89	3.89	45.3	45.3	53.3	53.3
	4.5	13.63	16.670	249	249	3.87	3.87	49.9	49.9	59.0	59.0
	6.0	17.95	21.630	311	311	3.79	3.79	62.3	62.3	75.1	75.1
125 x 125	3.2	12.31	15.330	376	376	4.95	4.95	60.1	60.1	69.6	69.6
	4.5	17.16	21.170	506	506	4.89	4.89	80.9	80.9	94.8	94.8
	6.0	22.66	27.630	641	641	4.82	4.82	103	103	122	122
150 x 150	4.5	20.69	25.670	896	896	5.91	5.91	120	120	139	139
	5.0	22.93	28.360	982	982	5.89	5.89	131	131	153	153
	6.0	27.37	33.630	1150	1150	5.84	5.84	153	153	180	180
	9.0	40.39	48.670	1580	1580	5.69	5.69	210	210	253	253
200 x 200	6.0	36.79	45.630	2830	2830	7.88	7.88	283	283	330	330
	9.0	54.52	66.670	3990	3990	7.73	7.73	399	399	472	472
	12.0	71.80	86.530	4980	4980	7.59	7.59	498	498	601	601
250 x 250	6.0	46.21	57.630	5670	5670	9.92	9.92	454	454	524	524
	9.0	68.64	84.670	8090	8090	9.78	9.78	647	647	759	759
	12.0	90.63	110.500	10300	10300	9.63	9.63	820	820	975	975
300 x 300	6.0	55.63	69.630	9960	9960	12.0	12.0	664	664	764	764
	9.0	82.78	102.700	14300	14300	11.8	11.8	956	956	1110	1110
	12.0	109.48	134.500	18300	18300	11.7	11.7	1220	1220	1440	1440
350 x 350	9.0	98.91	120.700	23200	23200	13.9	13.9	1320	1320	1530	1530
	12.0	128.32	158.500	29800	29800	13.7	13.7	1700	1700	1990	1990
400 x 400	9.0	111.04	138.700	35100	35100	15.9	15.9	1750	1750	2020	2020
	12.0	147.16	182.500	45300	45300	15.8	15.8	2270	2270	2640	2640

※ 1. 可接受不定尺訂製

※ 2. 大型方形鋼管尺寸規格客製化。

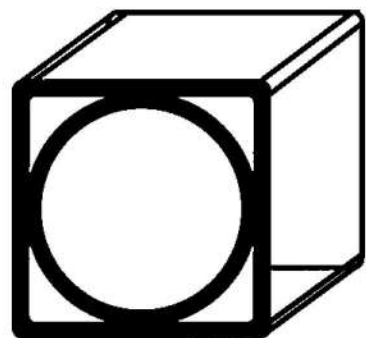
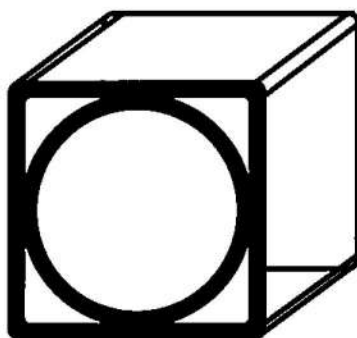
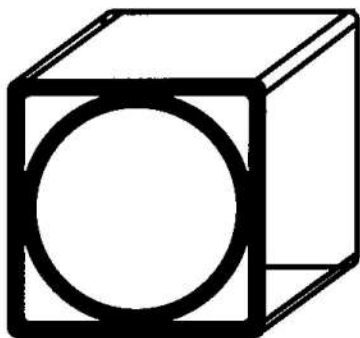

圓形管尺寸規格

規格	厚度	單位重	截面積	慣性矩	迴轉半徑	剖面係數	塑性剖面係數
外徑 (mm)	mm	kg/m	cm ²	cm ⁴	cm	cm ³	cm ³
33.7	3.2	2.41	2.89	3.44	1.09	2.04	2.84
42.4	3.2	3.09	3.71	7.25	1.40	3.42	4.67
48.3	3.5	3.87	4.93	12.4	1.59	5.15	7.04
	4.0	4.37	5.57	13.8	1.57	5.70	7.87
60.3	3.0	4.24	5.40	22.2	2.03	7.37	9.86
	4.0	5.55	7.07	28.2	2.00	9.34	12.7
76.1	3.0	5.41	6.89	46.1	2.59	12.1	16.0
	4.0	7.11	9.06	59.1	2.55	15.5	20.8
88.9	3.5	7.37	9.39	85.7	3.02	19.3	25.5
	4.0	8.38	10.7	96.3	3.00	21.7	28.9
	5.0	10.3	13.2	116	2.97	26.2	35.2
114.3	3.5	9.56	12.2	187	3.92	32.7	43.0
	4.0	10.9	13.9	211	3.90	36.9	48.7
	5.0	13.5	17.2	257	3.87	45.0	59.8
	6.0	16.0	20.4	300	3.83	52.5	70.4
139.7	4.0	13.4	17.1	393	4.80	56.2	73.7
	5.0	16.6	21.2	481	4.77	68.8	90.8
	6.0	19.8	25.2	564	4.73	80.8	107
168.3	4.0	16.2	20.6	697	5.81	82.8	108
	5.0	20.1	25.7	856	5.78	102	133
	6.0	24.0	30.6	1009	5.74	120	158
219.1	6.0	31.5	40.2	2282	7.54	208	273
	8.0	41.6	53.1	2960	7.47	270	357
273.0	6.0	39.5	50.3	4487	9.44	329	428
	8.0	52.3	66.6	5852	9.37	429	562
	10.0	64.9	82.6	7154	9.31	524	693
323.9	6.0	47.0	59.9	7572	11.2	468	606
	8.0	62.3	79.4	9910	11.2	612	799
	10.0	77.4	98.6	12158	11.1	751	986
355.6	6.0	51.7	65.9	10071	12.4	566	733
	8.0	68.6	87.4	13201	12.3	742	967
	10.0	85.2	109	16223	12.2	912	1195
	12.0	102	130	19139	12.2	1076	1417
406.4	6.0	59.2	75.6	15128	14.2	745	962
	8.0	78.6	100	19874	14.1	978	1270
	10.0	97.8	125	24476	14.0	1205	1572
	12.0	117	149	28937	14.0	1424	1867
457.0	6.0	66.7	85	21618	15.9	946	1220
	8.0	88.6	113	28446	15.9	1245	1613
	10.0	110	140	35091	15.8	1536	1998
	12.0	132	168	41556	15.7	1819	2377
	16.0	174	222	53959	15.6	2361	3113
508.0	6.0	74.3	95	29812	17.7	1174	1512
	8.0	98.6	126	39280	17.7	1546	2000
	10.0	123	156	48520	17.6	1910	2480
	12.0	147	187	57536	17.5	2265	2953
	16.0	194	247	74909	17.4	2949	3874

鋼材重量表

不銹鋼板 304				
	1M X 2M	3' X 6'	4' X 8'	5' X 10'
0.3	4.76	3.98	7.07	11.05
0.4	6.34	5.30	9.43	14.73
0.5	7.93	6.63	11.78	18.42
0.6	9.51	7.95	14.14	22.10
0.7	11.10	9.28	16.50	25.79
0.8	12.69	10.61	18.85	29.47
0.9	14.27	11.93	21.21	33.15
1.0	15.86	13.26	23.57	36.84
1.2	19.03	15.91	28.28	44.21
1.5	23.79	19.89	35.35	55.25
1.6	25.38	21.21	37.71	58.94
2.0	31.72	26.51	47.13	73.67
2.5	39.65	33.14	58.92	92.09
3.0	47.58	39.77	70.70	110.51
4.0	63.44	53.03	94.27	147.34
4.5	71.37	59.66	106.05	165.76
5.0	79.30	66.29	117.84	184.18
5.5	87.23	72.91	129.62	202.60
6.0	95.16	79.54	141.40	221.02
7.0	111.02	92.80	165.00	258.30
8.0	126.88	106.05	188.54	294.69
9.0	142.74	119.31	212.11	331.52
10.0	158.60	132.57	235.67	368.36
12.0	190.32	159.08	282.80	442.03
16.0	253.76	212.11	377.07	589.38
19.0	301.34	251.88	447.77	699.88
22.0	348.92	291.65	518.47	810.39
25.0	396.50	331.42	589.18	920.90

不銹鋼板 430				
	1M X 2M	3' X 6'	4' X 8'	5' X 10'
0.3	4.62	3.87	6.87	10.73
0.4	6.16	5.15	9.15	14.31
0.5	7.70	6.44	11.44	17.88
0.6	9.24	7.72	13.73	21.07
0.7	10.78	9.01	16.02	25.04
0.8	12.32	10.30	18.31	28.61
0.9	13.86	11.58	20.60	32.19
1.0	15.40	12.87	22.88	35.77
1.2	18.48	15.45	27.46	42.92
1.5	23.10	19.31	34.33	53.65
1.6	24.64	20.60	36.61	57.23
2.0	30.80	25.74	45.77	71.54
2.5	38.50	32.18	57.21	89.42
3.0	46.20	38.62	68.65	107.30

薄鋼板 SPHC SS-41		
	4' X 8'	5' X 10'
1.2	28.00	43.8
1.3	28.00	47.4
1.4	28.00	51.0
1.5	28.00	54.6
1.6	28.00	58.3
1.8	28.00	65.6
2.0	28.00	72.9
2.2	28.00	80.2
2.3	28.00	83.9
2.6	28.00	94.8
2.8	28.00	102
2.9	28.00	106
3.0	70.00	109

鋼板 SS-41 SB-42 SM-41			
	4' X 8'	5' X 10'	5' X 20'
3.2	74.7	117	233
4	93.3	146	292
4.5	105	164	328
5	117	182	365
6	140	219	438
7	163	255	510
8	187	292	583
9	210	328	656
10	233	365	729
11	257	401	802
12	280	438	875
13	303	474	948
14	327	510	1,021
15	350	547	1,094
16	373	584	1,167
17	396	620	1,239
18	420	656	1,313
19	444	693	1,386
20	467	730	1,459
22	513	802	1,604
25	583	912	1,823
28	653	1,021	2,042
30	700	1,094	2,188
30	747	1,167	2,334
35	817	1,276	2,553
36	840	1,312	2,625
38	887	1,386	2,771
40	933	1,458	2,917
42	981	1,534	3,068
45	1,050	1,641	3,282
50	1,167	1,823	3,646
55	1,284	2,006	4,011
60	1,400	2,188	4,376
65	1,517	2,370	4,740
70	1,634	2,552	5,105
75	1,750	2,735	5,470
80	1,867	2,917	5,834
85	1,983	3,099	6,198
90	2,100	3,282	6,564
95	2,217	3,464	6,928
100	2,334	3,647	7,293

磨光鋼板 SPCC SPCD SPCE		
USG#	mm	4' X 8'
30	0.318	7.42
29	0.357	8.33
28	0.397	9.26
27	0.437	10.20
26	0.476	11.10
25	0.556	13.00
	0.600	14.00
24	0.635	14.80
	0.700	16.30
23	0.714	16.70
22	0.784	18.50
	0.800	18.70
21	0.873	20.40
	0.900	21.00
20	0.952	22.20
	1.000	23.30
19	1.111	25.90
	1.200	28.00
18	1.270	29.60
17	1.429	33.40
	1.500	35.00
16	1.558	36.30
	1.600	37.30
15	1.786	41.80
14	1.984	46.20
	2.000	46.70
	2.300	53.70
13	2.381	55.50
	3.200	74.70

H型鋼				
A	B	t ₁	t ₂	kg/M
100	100	6.00	8	17.2
125	125	6.50	9	23.8
150	150	7.00	10	31.5
175	175	7.50	11	40.2
200	200	8.00	12	49.9
250	250	9.00	14	72.4
300	300	10.00	15	94.0
350	350	12.00	19	137.0
400	400	13.00	21	172.0
148	100	6.00	9	21.1
194	150	6.00	9	30.6
244	175	7.00	11	44.1
294	200	8.00	12	56.8
340	250	9.00	14	79.7
390	300	10.00	16	107.0
440	300	11.00	18	124.0
488	300	11.00	18	128.0
588	300	12.00	20	151.0
100	50	5.00	7	9.3
125	60	6.00	8	13.2
150	75	5.00	7	14.0
175	90	5.00	8	18.1
200	100	5.50	8	21.3
250	125	6.00	9	29.6
300	150	6.50	9	36.7
350	175	7.00	11	49.6
400	200	8.00	13	66.0
450	200	9.00	14	76.0
500	200	10.00	16	89.7
600	200	11.00	17	106.0

工字鐵				
A	B	t	t	kg/M
150	5	5.50	9.50	17.1
200	75	7.00	10.00	26.0
200	100	9.00	16.00	50.4
250	150	7.50	12.50	38.3
250	125	10.00	19.00	55.5
300	125	8.00	13.00	48.3
300	150	10.00	18.50	65.5
300	150	11.50	22.00	76.8
350	150	9.00	15.00	58.5
350	150	12.00	24.00	87.2
400	150	10.00	18.00	72.0
400	150	12.50	25.00	95.8
450	175	11.00	20.00	91.7
450	175	13.00	26.00	115.0
600	190	13.00	25.00	133.0
600	190	16.00	35.00	176.0

槽鐵				
A	B	t	t	kg/M
75	40	5.00	7.00	6.9
100	50	5.00	7.50	9.4
125	65	6.00	8.00	13.4
150	75	6.50	10.50	18.6
150	75	9.00	12.50	24.0
180	75	7.00	10.50	21.4
200	80	7.50	11.00	24.6
200	90	8.00	13.50	30.3
250	90	9.00	13.00	34.6
300	90	9.00	13.00	38.1
300	90	10.00	15.50	43.8
380	100	10.50	16.00	54.5
380	100	13.00	20.00	67.3



鋼材重量表

無縫鋼管										
口徑 種類	JIS G3454 STPG38								外徑 mm	
	Sch 40				Sch 80					
	厚度mm	kg/M	厚度mm	kg/M	厚度mm	kg/M	厚度mm	kg/M		
3/8"	17.3	2.3	0.85	3.2	1.11	17.1	2.3	0.85	3.2	1.10
1/2"	21.7	2.8	1.31	3.7	1.64	21.3	2.8	1.27	3.7	1.62
3/4"	27.2	2.9	1.74	3.9	2.24	26.7	2.9	1.68	3.9	2.19
1"	34.0	3.4	2.57	4.5	3.27	33.4	3.4	2.50	4.6	3.23
1 1/4"	42.7	3.6	3.47	4.9	4.57	42.2	3.6	3.38	4.9	4.47
1 1/2"	48.6	3.7	4.10	5.1	5.47	48.3	3.7	4.05	5.1	5.41
2"	60.5	3.9	5.44	5.5	7.46	60.3	3.9	5.44	5.5	7.48
2 1/2"	76.3	5.2	9.12	7.0	12.00	73.0	5.2	8.62	7.0	11.41
3"	89.1	5.5	11.30	7.6	15.30	88.9	5.5	11.29	7.6	15.27
3 1/2"	101.6	5.7	13.50	8.1	18.70	101.6	5.7	13.57	8.1	18.63
4"	114.3	6.0	16.00	8.6	22.40	114.3	6.0	16.07	8.6	22.31
5"	139.8	6.6	21.70	9.5	30.50	141.3	6.6	21.78	9.5	30.95
6"	165.2	7.1	27.70	11.0	41.80	168.3	7.1	28.26	11.0	42.56
8"	216.2	8.2	42.10	12.7	63.80	219.1	8.2	42.53	12.7	64.63
10"	267.4	9.3	59.20	15.1	93.90	273.0	9.3	60.29		
12"	318.5	10.3	78.30	14.7	129.00	323.8	9.5(S)	73.82	17.5	132.00
14"	355.6	11.1	94.30	19.0	158.00	355.6	9.5(S)	81.28	19.1	158.10
16"	406.4	12.7	123.00	21.4	203.00	406.4	12.7	123.30		

等邊三角鐵			不等邊三角鐵		
規格	厚	kg/M	規格	厚	kg/M
25 X 25	3	1.12	100 X 75	7	9.32
30 X 30	3	1.36	100 X 75	10	13.00
40 X 40	3	1.83	100 X 75	13	16.50
40 X 40	4	2.40	125 X 75	7	10.70
50 X 50	4	3.06	125 X 75	9	13.50
50 X 50	6	4.43	125 X 75	10	14.90
50 X 50	8	5.78	125 X 75	13	19.10
65 X 65	6	5.91	125 X 90	7	11.50
65 X 65	8	7.66	125 X 90	9	14.60
75 X 75	6	6.85	125 X 90	10	16.10
75 X 75	9	9.96	125 X 90	13	20.60
90 X 90	10	13.30	150 X 75	7	12.10
90 X 90	13	17.00	150 X 75	9	15.30
100 X 100	10	14.90	150 X 75	12	20.10
100 X 100	13	19.10	150 X 90	9	16.40
130 X 130	9	17.90	150 X 90	12	21.50
130 X 130	12	23.40	150 X 90	15	26.50
130 X 130	15	28.80	150 X 100	9	17.10
150 X 150	12	27.30	150 X 100	12	22.40
150 X 150	15	33.60	150 X 100	15	27.70
150 X 150	19	41.90	175 X 90	9	18.20
200 X 200	15	45.30	175 X 100	10	20.90
200 X 200	20	59.70	200 X 90	11	24.20
200 X 200	25	73.60	200 X 100	11	25.10

無縫鋼管 GIP-B SGP						
內徑 吋	JIS G3454 STPG38					
	外徑mm	厚度mm	kg/M	kg/M	厚度mm	kg/M
3/8"				17.30	2.3	0.851
1/2"	21.7	2.6	1.304	21.70	2.8	1.310
3/4"	27.2	2.8	1.855	27.20	2.8	1.680
1"	34.2	3.2	2.608	34.00	3.2	2.430
1 1/4"	42.8	3.6	3.721	42.70	3.5	3.380
1 1/2"	48.7	4.1	4.717	48.60	3.5	3.890
2"	60.8	4.1	5.989	60.50	3.8	5.310
2 1/2"	76.6	4.5	8.363	76.30	4.2	7.470
3"	89.5	4.5	9.858	89.10	4.2	8.790
3 1/2"	102.1	4.5	11.342	101.60	4.2	10.100
4"	114.9	4.5	12.826	114.30	4.5	12.200
5"	140.6	4.5	15.783	139.80	4.5	15.000
6"	166.1	4.5	18.758	165.20	5.0	19.800

丸鐵			平鐵		
φ mm	公斤/呎	公斤/公尺	規格 mm	公斤/公尺	公斤/呎
6	0.068	0.222	25 X 3	0.589	0.199
8	0.120	0.395	25 X 5	0.981	0.299
9	0.152	0.499	32 X 3	0.754	0.230
12	0.271	0.888	32 X 5	1.260	0.383
13	0.317	1.04	32 X 6	1.510	0.459
16	0.482	1.58	38 X 3	0.895	0.273
19	0.680	2.23	38 X 5	1.49	0.455
22	0.908	2.98	50 X 5	1.96	0.598
25	1.174	3.85	50 X 6	2.36	0.718
28	1.472	4.83	65 X 6	3.06	0.933
32	1.923	6.31	65 X 9	4.59	1.40
35	2.301	7.55	70 X 6	3.30	1.01
38	2.713	8.90	70 X 9	4.95	1.51
42	3.323	10.90	75 X 6	3.53	1.08
44	3.630	11.90	75 X 9	5.30	1.62
48	4.328	14.20	75 X 12	7.06	2.15
50	4.694	15.40	90 X 6	4.24	1.29
55	5.700	18.70	90 X 9	6.36	1.94
60	6.767	22.20	90 X 12	8.48	2.58
65	7.925	26.00	100 X 6	4.71	1.44
75	10.577	34.70	100 X 9	7.06	2.15
90	15.210	49.90	100 X 12	9.42	2.87
100	18.806	61.70	125 X 12	8.83	2.69

花紋鋼板					
	4' X 8'	5' X 10'		4' X 8'	5' X 10'
3	72.5	113.5	6	145	227
3.2	79.6	124.5	8	192	299
4.5	110.0	172.0	9	215	336

有孔花紋鋼板							
記號	番數	T	SW	LW	W	4' X 8'	5' X 10'
XG	52	2.3	25mm	61mm	3	12.9	20.1
	62	3.2	34	76.2	4	17.6	27.5
	11	4.5	34	135.4	7	43.1	67.4
	12	6.0	34	135.4	7	57.6	90.1
	13	6.0	34	135.4	9	74.0	116.0
	14	8.0	34	135.4	9	98.7	154.0
	21	4.5	36	101.6	7	40.7	63.6
	22	6.0	36	101.6	7	54.4	85.0
	23	6.0	36	101.6	9	70.1	110.0
	24	8.0	36	101.6	9	93.3	146.0

度量衡換算表						
面積單位換算表 CONVERSION TABLES OF AREAS						
SO. METER 平方公尺	SO. INCH 平方呎	SO. FOOT 平方呎	ACRE英畝	SO. MILE 平方英里	SO. CM. 平方公分	SO. MM 平方公厘
1	1550	10.76	0.0002471	0.063861	10000	106
0.0006452	1	0.006944	0.041594	0.092491	6.452	645.2
0.09290	144	1	0.062296	0.073587	929.0	92900
4047	6272640	43560	1	0.001562	40470000	4047X10 ⁶
2589998		27878400	640	1	25.9X10 ⁶	25.9X10 ¹¹

1公頃 = 100公畝 = 10,000平方公尺 = 2.471英畝 = 1.0310甲
1甲 = 96.99174公畝 = 2.3267英畝 = 2934坪

鋼軌						
kg	寸法 mm					kg/W
	A	B	C	D	T	
6	50.80	50.80	25.40	14.29	4.76	5.98
9	63.50	63.50	32.10	17.48	5.90	8.94
12	69.85	69.85	38.10	19.85	7.54	12.20
15	79.37	79.37	42.86	22.22	8.33	15.20
22	93.66	93.66	50.80	26.99	10.72	22.30
30	107.95	107.95	60.33	30.95	12.30	30.10
37	122.24	122.24	62.71	36.12	13.49	37.20
50	144.46	127.00	67.87	46.04	14.29	50.40
50N	153.00	137.00	65.00	49.00	15.00	50.40
73	135.00	140.00	100.00	-	32.00	73.30

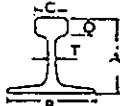
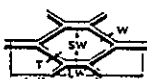

- 10吋 = 2.53995
- 1 M = 1.093633碼
- 1呎 = 0.6214哩
- 1哩 = 1.609315呎
- 1里 = 3.92727呎
- 1呎 = 0.40677里
- 1里 = 2.44033哩
- 1kg/mm² = 0.000703PSI(1b/in²)
- 1PSI = 1,422.3kg/mm²
- 1MPa = 145.01PSI
- 11b/ft = 1.488kg/M.
- 1mm = 0.09397吋 = 0.00328呎
- 1吋 = 25.40mm = 0.0254M
- 1呎 = 304.8mm = 0.3048M
- 1 M = 39.37吋 = 3.28083呎
- 1尺 = 303.03mm = 0.30303M
- 1尺 = 11.93吋 = 0.99419呎
- 1公斤 = 2.20452磅 = 0.26667貫
- 1磅 = 0.45359公斤 = 0.12096貫
- 1噸 = 1,000公斤 = 2.2046磅
- 1碼 = 0.91438M = 0.50291閘
- 1 = 0.39371吋

鋼管厚度重量對照表

CARBON STEEL PIPE																									
STPG(JIS G3454) · STS(JIS G3455) · STPT(JIS G3456)																									
N.B.	O.D.	NOMINAL THICKNESS																							
		Sch/20			Sch/30			Sch/40			Sch/60			Sch/80			Sch/100		Sch/120		Sch/160				
		THICK mm	WGT kg/m	5.5M kg	THICK mm	WGT kg/m	5.5M kg	THICK mm	WGT kg/m	5.5M kg	THICK mm	WGT kg/m	5.5M kg	THICK mm	WGT kg/m	5.5M kg	THICK mm	WGT kg/m	5.5M kg	THICK mm	WGT kg/m	5.5M kg	THICK mm	WGT kg/m	5.5M kg
6	1/8	10.5	—	—	—	—	—	—	—	1.7	.369	2.03	2.2	.450	2.48	2.4	.479	2.63	—	—	—	—	—	—	—
8	1/4	13.8	—	—	—	—	—	—	—	2.2	.629	3.46	2.4	.675	3.71	3.0	.799	4.39	—	—	—	—	—	—	—
10	3/8	17.3	—	—	—	—	—	—	—	2.3	.851	4.68	2.8	1.00	5.50	3.2	1.11	6.10	—	—	—	—	—	—	—
15	1/2	21.7	—	—	—	—	—	—	—	2.8	1.31	7.20	3.2	1.46	8.03	3.7	1.64	9.02	—	—	—	—	4.7	1.97	10.8
20	3/4	27.2	—	—	—	—	—	—	—	2.9	1.74	9.57	3.4	2.00	11.0	3.9	2.24	12.3	—	—	—	—	5.5	2.94	16.2
25	1	34.0	—	—	—	—	—	—	—	3.4	2.57	14.1	3.9	2.89	15.9	4.5	3.27	18.0	—	—	—	—	6.4	4.36	24.0
32	1 1/4	42.7	—	—	—	—	—	—	—	3.6	3.47	19.1	4.5	4.24	23.3	4.9	4.57	25.1	—	—	—	—	6.4	5.73	31.5
40	1 1/2	48.6	—	—	—	—	—	—	—	3.7	4.10	22.6	4.5	4.89	26.9	5.1	5.47	30.1	—	—	—	—	7.1	7.27	40.0
50	2	60.5	3.2	4.52	24.9	—	—	—	—	3.9	5.44	29.9	4.9	6.72	37.0	5.5	7.46	41.0	—	—	—	—	8.7	11.1	61.0
65	2 1/2	76.3	4.5	7.97	43.8	—	—	—	—	5.2	9.12	50.2	6.0	10.4	57.2	7.0	12	66.0	—	—	—	—	9.5	15.6	85.8
80	3	89.1	4.5	9.39	51.6	—	—	—	—	5.5	11.3	62.2	6.6	13.4	73.7	7.6	15.3	84.2	—	—	—	—	11.1	21.4	118.0
90	3 1/2	101.6	4.5	10.8	59.4	—	—	—	—	5.7	13.5	74.2	7.0	16.3	89.6	8.1	18.7	103	—	—	—	—	12.7	27.8	153.0
100	4	114.3	4.9	13.2	72.6	—	—	—	—	6.0	16.0	88.0	7.1	18.8	103	8.6	22.4	123	—	—	11.1	28.2	13.5	33.6	185.0
125	5	139.8	5.1	16.9	93.0	—	—	—	—	6.6	21.7	119	8.1	26.3	145	9.5	30.5	168	—	—	12.7	39.8	15.9	48.6	267.0
150	6	165.2	5.5	21.7	119.0	—	—	—	—	7.1	27.7	152	9.3	35.8	197	11	41.8	230	—	—	14.3	53.2	18.2	66.0	363.0
200	8	216.3	6.4	33.1	182.0	7.0	36.1	199.0	8.2	42.1	232	10.3	52.3	288	12.7	63.8	351	15.1	74.9	18.2	88.9	23	110	605.0	
250	10	267.4	6.4	41.2	227.0	7.8	49.9	274.0	9.3	59.2	326	12.7	79.8	439	15.1	93.9	516	18.2	112	21.4	130	28.6	168	924.0	
300	12	318.5	6.4	49.3	271.0	8.4	64.2	353.0	10.3	78.3	431	14.3	107	588	17.4	129	710	21.4	157	25.4	184	33.3	234	1287.0	
350	14	355.6	7.9	67.7	372.0	9.5	81.1	446.0	11.1	94.3	519	15.1	127	698	19	158	869	23.8	195	27.8	255	35.7	282	1551.0	
400	16	406.4	7.9	77.6	427.0	9.5	93.0	512.0	12.7	123	676	16.7	160	880	21.4	203	1116	26.2	246	30.9	286	40.5	365	2008.0	
450	18	457.2	7.5	87.5	481.0	11.1	122	671.0	14.3	156	858														
500	20	508.0	9.5	117	644.0	12.7	155	852.0	15.1	184	1012														

JISG3457STPY ARC WELDED CARBON STEEL PIPES															(Unit:kg/m)	
Nominal Diameter		Wall Thickness mm Outside Dia mm	6.0	6.4	7.1	7.9	8.7	9.5	10.3	11.1	11.9	12.7	13.1	15.1	15.9	
A	B		6.0	6.4	7.1	7.9	8.7	9.5	10.3	11.1	11.9	12.7	13.1	15.1	15.9	
350	14	355.6	51.7	55.1	61.0	67.7										
400	16	406.4	59.2	63.1	66.9	77.6										
450	18	457.2	66.8	71.1	78.8	87.5										
500	20	508.0	74.3	79.2	87.7	97.4	107	117								
550	22	558.8	81.8	87.2	96.6	107	118	129	139	150	160	171				
600	24	609.6	89.3	95.2	105	117	129	141	152	164	175	187				
650	26	660.4	96.8	103	114	127	140	152	165	178	190	203				
700	28	711.2	104	111	123	137	151	164	178	192	205	219				
750	30	762.0		119	132	147	162	176	191	206	220	235				
800	32	812.8		127	141	157	173	188	204	219	235	251	258	297	312	
850	34	863.6				167	183	200	217	233	250	266	275	316	332	
900	36	914.4				177	194	212	230	247	265	282	291	335	352	
1,000	40	1016.0				196	216	236	255	275	295	314	324	373	392	
1,100	44	1117.6					260	281	303	324	346	357	411	432		
1,200	48	1219.2					283	307	331	354	378	390	448	472		
1,350	54	1371.6								399	426	439	505	532		
1,350	60	1524.0								444	473	488	562	591		
1,350	64	1625.6										521	600	631		
1,350	72	1828.8										587	675	711		
1,350	80	2032.0											751	791		

鋼管厚度重量對照表

Welded and Seamless Steel Pipe										SEAMLESS PIPE: READY STOCK FOR PROMPT SHIPMENT													
ASTM A53 GR.B/API Std 5L GR.B.																							
N.B.	OUT SIDE DIAMETER		SCH 20			STD			SCH 40				XS			SCH 80				SCH 160			
			THICH		W.	THICH		W.	THICH		WEIGHT		THICH	W.		THICH		WEIGHT		THICH		WEIGHT	
	inch	mm	inch	mm	kg/m	inch	mm	kg/m	inch	mm	kg/m	6M kg	inch	mm	kg/m	2.41	mm	kg/m	6M kg	inch	mm	kg/m	6M kg
1/8"	.450	10.3	—	—	—	.068	1.73	.36	.068	1.73	.36	2.16	0.95	2.41	0.46	0.95	2.41	.46	2.76	—	—	—	—
1/4"	.540	13.7	—	—	—	.088	2.24	.63	.088	2.24	.63	3.78	.119	3.02	0.80	.119	3.02	.80	4.80	—	—	—	—
3/8"	.675	17.1	—	—	—	.091	2.31	.85	.091	2.31	.85	5.10	.126	3.20	1.10	.126	3.20	1.10	6.60	—	—	—	—
1/2"	.840	21.3	—	—	—	.109	2.77	1.27	.109	2.77	1.27	7.62	.147	3.73	1.62	.147	3.73	1.62	9.72	.188	4.78	1.95	11.7
3/4"	1.050	26.7	—	—	—	.113	2.87	1.68	.113	2.87	1.68	10.1	.154	3.91	2.19	.154	3.91	2.19	13.1	.219	5.56	2.89	17.3
1"	1.315	33.4	—	—	—	.133	3.38	2.50	.133	3.38	2.50	15.0	.179	4.55	3.23	.179	4.55	3.23	19.4	.250	6.35	4.23	25.4
1 1/4"	1.660	42.2	—	—	—	.140	3.56	3.38	.140	3.56	3.38	20.3	.191	4.85	4.47	.191	4.85	4.47	26.8	.250	6.35	5.60	33.6
1 1/2"	1.900	48.3	—	—	—	.145	3.68	4.05	.145	3.68	4.05	24.3	.200	5.08	5.41	.200	5.08	5.41	32.5	.281	7.14	7.24	43.4
2"	2.375	60.3	—	—	—	.154	3.91	5.44	.154	3.91	5.44	32.6	.218	5.54	7.48	.218	5.54	7.48	44.9	.344	8.74	11.11	66.7
2 1/2"	2.875	73.0	—	—	—	.203	5.16	8.62	.203	5.16	8.62	51.7	.276	7.01	11.41	.276	7.01	11.41	68.5	.375	9.53	14.91	89.5
3"	3.500	88.9	—	—	—	.216	5.49	11.29	.216	5.49	11.29	67.7	.300	7.62	15.27	.300	7.62	15.27	91.6	.438	11.13	21.33	128
3 1/2"	4.00	101.6	—	—	—	.226	5.74	13.57	.226	5.74	13.57	81.4	.318	8.08	18.63	.318	8.08	18.63	112	—	—	—	—
4"	4.500	114.3	—	—	—	.237	6.02	16.07	.237	6.02	16.07	96.4	.337	8.56	18.63	.337	8.56	18.63	134	.531	13.49	33.53	201
5"	5.563	141.3	—	—	—	.258	6.55	21.78	.258	6.55	21.78	131	.375	9.52	22.31	.375	9.52	22.31	186	.625	15.88	49.09	295
6"	6.625	168.3	—	—	—	.280	7.11	28.26	.280	7.11	28.26	170	.432	10.97	30.95	.432	10.97	30.95	255	.719	18.26	67.55	405
8"	8.625	219.1	.250	6.35	33.31	.322	8.18	42.53	.322	8.18	42.53	255	.500	12.7	42.56	.500	12.7	42.56	388	.906	23.01	11.25	668
10"	10.750	273.0	.250	6.35	41.77	.365	9.27	60.29	.365	9.27	60.29	362	.500	12.7	81.54	.594	15.09	95.97	576	1125	28.57	172.26	1034
12"	12.750	323.8	.250	6.35	49.72	.375	9.52	73.82	.406	10.31	79.72	478	.500	12.7	97.44	.688	17.48	132.01	792	1312	33.32	238.72	1432
14"	14.000	355.6	.312	7.92	67.94	.375	9.52	81.28	.438	11.13	94.49	567	.500	12.7	107.40	.750	19.05	158.08	948	1406	35.71	281.68	1690
16"	16.000	406.4	.312	7.92	77.86	.375	9.52	93.21	.500	12.7	123.29	740	.500	12.7	123.29	.844	21.44	203.53	1221	1594	40.49	365.36	2192

ENDS: 1 1/2" & UNDER PLAIN SQUARE CUT ENDS.
2" & ABOVE BEVELLED ENDS.

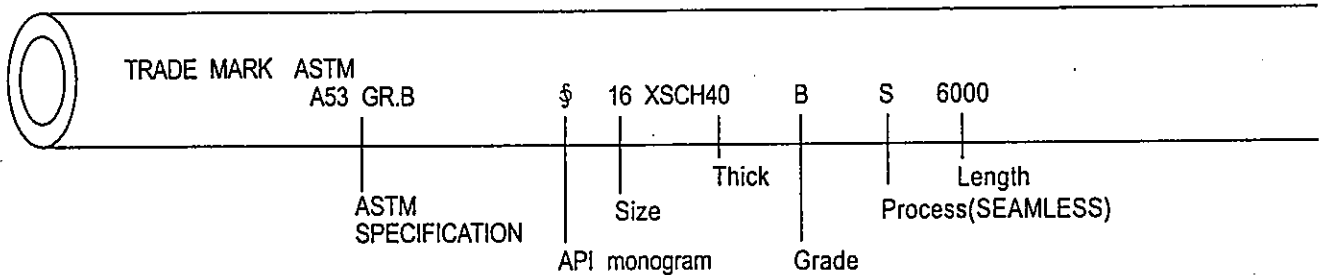

SGP · SCH40 有縫對焊管件重量表

單位：kg / 個

規格 \ 品名	90°彎頭		45°彎頭		三通		管帽	
	SGP	SCH40	SGP	SCH40	SGP	SCH40	SGP	SCH40
1/2"	0.08	0.10	0.04	0.05	0.20	0.20		0.10
3/4"	0.11	0.10	0.055	0.05	0.20	0.20		0.10
1"	0.15	0.20	0.075	0.10	0.40	0.40		0.10
1 1/4"	0.30	0.30	0.15	0.15	0.50	0.50		0.20
1 1/2"	0.40	0.40	0.20	0.20	0.70	0.80		0.30
2"	0.70	0.80	0.35	0.40	0.90	1.00	0.32	0.40
2 1/2"	1.20	1.50	0.60	0.75	2.00	2.00	0.55	0.50
3"	1.60	2.00	0.80	1.00	2.50	2.50	0.90	1.00
4"	3.00	4.00	1.50	2.00	4.00	4.00	1.20	2.00
5"	5.00	7.00	2.50	3.50	6.00	7.00	2.00	3.00
6"	7.00	10.00	3.50	5.00	9.00	10.00	2.50	4.00
8"	14.20	20.00	7.10	10.00	15.00	20.00	5.00	5.00
10"	23.00	35.00	11.50	17.50	25.00	35.00	8.00	7.00
12"	35.00	59.00	17.50	29.50	35.00	59.00	9.50	13.00

規格 \ 品名	同心大小頭		異徑三通		規格 \ 品名	同心大小頭		異徑三通	
	SGP	SCH40	SGP	SCH40		SGP	SCH40	SGP	SCH40
3/4"X1/2"	0.12	0.14	0.20	0.20	4"X3"	1.50	1.50	4.00	4.00
1"X3/4"-1/2"	0.15	0.20	0.40	0.40	5"X1 1/2"	2.50	3.50	6.00	7.00
1 1/4"X1/2"	0.20	0.30	0.50	0.50	5"X2"	2.50	3.50	6.00	7.00
1 1/4"X1"-3/4"	0.20	0.30	0.50	0.50	5"X2 1/2"	2.50	3.50	6.00	7.00
1 1/2"X3/4"	0.30	0.40	0.70	0.80	5"X3"	2.50	3.50	6.00	7.00
1 1/2"X1 1/4"-1"	0.30	0.40	0.70	0.80	5"X4"	2.50	3.50	6.00	7.00
2"X1/2"	0.40	0.50	0.90	1.00	6"X2"	3.50	4.50	9.00	10.00
2"X1"-3/4"	0.40	0.50	0.90	1.00	6"X2 1/2"	3.50	4.50	9.00	10.00
2"X1 1/2"-1 1/4"	0.40	0.50	0.90	1.00	6"X3"	3.50	4.50	9.00	10.00
2 1/2"X3/4"	0.80	1.00	2.00	2.00	6"X5" - 4"	3.50	4.50	9.00	10.00
2 1/2"X1"	0.80	1.00	2.00	2.00	8"X3"	6.00	6.00	15.00	20.00
2 1/2"X1 1/4"	0.80	1.00	2.00	2.00	8"X4"	6.00	6.00	15.00	20.00
2 1/2"X2"-1 1/2"	0.80	1.00	2.00	2.00	8"X5"	6.00	6.00	15.00	20.00
3"X1"	1.00	1.20	2.50	2.50	8"X6"	6.00	6.00	15.00	20.00
3"X1 1/4"	1.00	1.20	2.50	2.50	10"X4"	10.00	10.00	25.00	35.00
3"X1 1/2"	1.00	1.20	2.50	2.50	10"X5"	10.00	10.00	25.00	35.00
3"X2 1/2"-2"	1.00	1.20	2.50	2.50	10"X6"	10.00	10.00	25.00	35.00
4"X1 1/4"-1"	1.50	1.50	4.00	4.00	10"X8"	10.00	10.00	25.00	35.00
4"X1 1/2"	1.50	1.50	4.00	4.00	12"X6"-5"	15.00	15.00	35.00	59.00
4"X2"	1.50	1.50	4.00	4.00	12"X8"	15.00	15.00	35.00	59.00
4"X2 1/2"	1.50	1.50	4.00	4.00	12"X10"	15.00	15.00	35.00	59.00

遠東®內刮黑鋼管 / 鍍鋅鋼管

專用於：1.瓦斯配管。 2.消防配管。 3.空調配管。 4.導線配管。

特 點：1.管內無突出物，流動阻力小。 2.管內不易積污垢。 3.延長鋼管使用年限。 4.管內無焊渣。

■ 壓力配管用鋼管ASTM A53 LINE PIPE，直徑1"以上配管一律採用內焊屑刮除製程

稱呼尺寸 Nom Size	外徑 O.D.		厚度 Wall Thickness		重量 Weight		Schedule No	最低試驗壓力 Minimum Test Pressure			
								Grade A		Grade B	
inch	inch	mm	inch	mm	kg/ft	kg/m		psi	kg/cm2	psi	kg/cm2
1/2	0.840	21.3	0.109	2.8	0.39	1.28	40 STD	700	49	700	49
			0.147	3.7	0.49	1.62	80	850	60	850	60
3/4	1.050	26.7	0.113	2.9	0.51	1.67	40 STD	700	49	700	49
			0.154	3.9	0.67	2.19	80	850	60	850	60
1	1.315	33.4	0.133	3.4	0.76	2.49	40 STD	700	49	700	49
			0.179	4.6	0.99	3.23	80	850	60	850	60
1 1/4	1.660	42.2	0.140	3.6	1.03	3.38	40 STD	1,000	70	1,100	78
			0.191	4.8	1.36	4.47	80	1,800	127	1,900	134
1 1/2	1.900	48.3	0.145	3.7	1.24	4.01	40 STD	1,000	70	1,100	78
			0.200	5.1	1.65	5.41	80	1,800	127	1,900	134
2	2.357	60.3	0.154	3.9	1.66	5.44	40 STD	2,300	162	2,500	175
			0.218	5.5	5.03	7.48	80	2,500	176	2,500	176
2 1/2	2.875	73.0	0.203	5.2	2.63	8.63	40 STD	2,500	176	2,500	175
3	3.500	88.9	0.216	5.5	3.45	11.32	40 STD	2,200	155	2,500	175
3 1/2	4.000	101.6	0.226	5.7	4.14	13.58	40 STD	2,000	141	2,400	169
4	4.500	114.3	0.237	6.0	4.90	16.07	40 STD	1,900	134	2,200	155
5	5.563	141.3	0.258	6.6	6.65	21.81	40 STD	1,700	120	1,900	134
6	6.625	168.3	0.280	7.1	8.62	28.27	40 STD	1,500	106	1,800	127
8	8.625	219.1	0.250	6.4	10.15	33.31	20	1,000	70	1,200	85
			0.277	7.0	11.21	36.79	30	1,200	85	1,300	92
			0.322	8.2	12.96	42.53	40 STD	1,300	92	1,600	113
10	10.750	273.0	0.250	6.4	12.73	41.77	20	850	60	1,000	70
			0.307	7.8	14.64	48.02	30	1,000	70	1,200	85
			0.365	9.3	18.38	60.29	40 STD	1,200	85	1,400	99
12	12.750	323.9	0.250	6.4	15.15	49.72	20	700	49	800	56
			0.330	8.4	19.87	65.20	30	950	67	1,100	78
			0.375	9.5	22.50	73.80	STD	1,060	75	1,240	87
14	14.000	355.6	0.406	10.3	24.32	79.78	40	1,100	78	1,300	92
			0.250	6.4	16.67	56.68	10	650	46	750	53
			0.312	7.9	20.74	68.04	20	800	56	950	67
16	16.000	406.4	0.375	9.5	24.77	81.28	30 STD	950	67	1,100	78
			0.438	11.1	28.77	94.39	40	1,100	78	1,300	92
			0.250	6.4	19.09	62.63	10	550	39	650	46
18	18.000	457.2	0.312	7.9	23.77	77.99	20	700	49	800	56
			0.375	9.5	28.41	93.21	30 STD	850	60	1,000	70
			0.500	12.7	37.58	123.29	40	1,100	78	1,300	92
20	20.000	508.0	0.250	6.4	21.52	70.59	10	500	35	600	42
			0.312	7.9	26.80	87.93	20	600	42	750	53
			0.375	9.5	32.10	105.10	STD	750	53	875	62
22	22.000	558.8	0.438	11.1	37.26	122.23	30	900	63	1,000	70
			0.562	14.3	47.51	155.87	40	1,124	79	1,311	92
			0.250	6.4	23.94	78.55	10	450	32	520	37
24	24.000	609.6	0.312	7.9	29.77	97.67	-	560	39	660	47
			0.375	9.5	35.67	117.02	20 STD	680	48	790	56
			0.406	10.3	38.57	126.53	-	730	51	850	60
26	26.000	660.4	0.438	11.1	41.57	136.37	-	790	56	920	65
			0.500	12.7	47.28	155.12	30	900	63	1,050	74
			0.594	15.1	55.91	183.42	40	1,170	82	1,250	88
28	28.000	711.2	0.812	20.6	75.54	247.83	60	1,460	103	1,710	120
			0.375	9.5	35.67	128.95	STD	612	43	714	50
			0.250	6.4	28.79	94.46	10	380	27	440	31
30	30.000	762	0.312	7.9	35.82	117.51	-	470	33	550	39
			0.375	9.5	42.94	140.88	20 STD	560	39	660	47
			0.406	10.3	46.44	152.37	-	610	43	710	50
32	32.000	812.8	0.438	11.1	50.07	164.26	-	660	47	770	54
			0.500	12.7	56.98	186.94	-	750	53	880	62
			0.562	14.3	63.86	209.50	30	840	59	980	69
34	34.000	863.6	0.688	17.5	77.80	255.24	40	1,030	73	1,200	85
			0.250	6.4	31.22	102.42	-	350	25	400	28
			0.312	7.9	38.84	127.43	10	430	30	500	35
36	36.000	914.4	0.375	9.5	46.57	152.80	STD	520	37	610	43
			0.406	10.3	50.38	165.28	-	560	39	660	47
			0.438	11.1	54.32	178.20	-	610	43	710	50
38	38.000	965.2	0.500	12.7	61.83	202.85	20	690	49	810	57
			0.562	14.3	69.30	227.37	-	780	55	910	64
			0.375	9.5	50.21	164.73	STD	482	34	562	40
40	40.000	1016	0.375	9.5	53.82	176.73	STD	450	32	525	37
42	42.000	1066.8	0.375	9.5	57.48	188.58	STD	422	30	492	35

遠東®內刮黑鋼管 / 鍍鋅鋼管

專用於：1.瓦斯配管。 2.消防配管。 3.空調配管。 4.導線配管。

特 點：1.管內無突出物，流動阻力小。 2.管內不易積污垢。 3.延長鋼管使用年限。 4.管內無焊渣。

■ BS1387 A&B級一般配管用鋼管ERW STEEL PIPE，直徑1"以上配管一律採用內焊屑刮除製程

稱呼尺寸 Nom Size	最大外徑 Outside Diameter Max		壁厚 Wall Thickness	計算重量 Calculated Weight											
				平端 Plain End						附螺牙接頭 Threads & Coupling					
				lb/ft		kg/ft		kg/m		lb/ft		kg/ft		kg/m	
吋 inch	公厘 mm	黑bl	白gal	黑bl	白gal	黑bl	白gal	黑bl	白gal	黑bl	白gal	黑bl	白gal	黑bl	白gal
1/2 A B	0.841 0.858	21.4 21.8	1.90 2.60	0.607 0.825	0.649 0.875	0.275 0.374	0.294 0.396	0.904 1.230	0.967 1.304	0.614 0.831	0.657 0.881	0.279 0.377	0.299 0.400	0.913 1.240	0.977 1.314
	3/4 A B	1.059 1.075	26.9 27.3	2.10 2.90	0.853 1.173	0.913 0.243	0.387 0.532	0.414 0.564	1.271 1.750	1.360 1.855	0.860 1.182	0.920 1.253	0.390 0.536	0.417 5.568	1.280 1.760
1 A B		1.328 1.346	33.8 34.2	2.45 3.20	1.260 1.651	1.348 1.750	0.572 0.749	0.612 0.794	1.880 2.460	2.012 2.608	1.280 1.664	1.370 1.764	0.581 0.755	0.622 0.800	1.900 2.480
	1-1/4 A B	1.670 1.689	42.5 42.9	2.45 3.60	1.610 2.357	1.723 2.498	0.730 1.070	0.781 1.134	2.400 3.510	2.568 3.721	1.630 2.375	1.744 2.518	0.739 1.080	0.791 1.145	2.430 3.530
1-1/2 A B		1.903 1.921	48.4 48.8	2.60 4.10	1.960 2.988	2.097 3.167	0.889 1.360	0.951 1.442	2.920 4.450	3.124 4.717	1.990 3.015	2.129 3.196	0.903 1.370	0.966 1.452	2.960 4.490
	2 A B	2.370 2.394	60.2 60.8	2.60 4.10	2.470 3.795	2.643 4.023	1.120 1.720	1.198 1.823	3.670 5.650	3.927 5.989	2.510 3.836	2.686 4.066	1.139 1.740	1.219 1.844	3.740 5.740
2-1/2 A B		2.991 3.016	76.0 76.6	3.00 4.50	3.610 5.301	3.863 5.619	1.653 2.400	1.752 2.544	5.421 7.890	5.746 8.363	3.690 5.375	3.948 5.698	1.674 2.440	1.791 2.586	5.490 8.000
	3 A B	3.491 3.524	88.7 89.5	3.00 4.50	4.240 6.246	4.537 6.621	1.942 2.830	2.058 3.000	6.369 9.300	6.752 9.858	4.350 6.354	4.655 6.735	1.973 2.880	2.111 3.053	6.480 9.460
3-1/2 A B		3.981 4.020	101.2 102.1	3.25 4.50	5.250 7.172	5.618 7.602	2.484 3.302	2.633 3.50	8.148 10.83	9.998 11.479	5.380 7.288	5.757 7.725	2.440 3.310	2.611 3.509	8.000 10.800
	4 A B	4.481 4.528	113.9 115.0	3.25 4.50	5.930 8.117	6.345 8.604	2.704 3.738	2.866 3.962	8.868 12.262	9.4 12.977	6.140 8.286	6.570 8.783	2.785 3.760	2.980 3.975	9.140 12.300
5 A B		5.536 5.536	140.6 140.6	3.60 4.50	8.158 10.006	8.648 10.606	3.710 4.604	3.931 4.88	12.162 15.103	12.892 16.009	8.438 10.262	8.992 10.878	3.856 4.660	4.687 4.940	12.649 15.270
	6 A B	6.541 6.541	166.1 166.1	3.60 4.50	9.676 11.891	10.257 12.605	4.398 5.467	4.660 5.795	14.426 17.932	15.292 19.007	10.236 12.301	10.667 13.039	4.574 5.580	4.848 5.915	15.003 18.310
8 A B		8.625 8.625	219.1 219.1	4.50 6.00	15.657 20.878	16.441 21.923	7.26 9.612	7.695 10.188	23.814 31.53	25.242 33.421					
	10 A B	10.750 10.750	273.0 273.0	4.50 6.00	19.455 25.938	20.427 27.170	9.083 12.044	9.629 12.766	29.795 39.505	33.582 41.875					
12 A B		12.750 12.750	323.8 323.8	4.50 6.00	23.232 30.976	24.394 32.525	10.802 14.335	11.45 15.196	35.432 47.021	37.557 49.842					
	14 B	14.000	355.6	6.00	34.694	36.430	15.770	16.559	51.726	54.312					
16 B	16.000	406.4	6.00	39.732	41.719	18.061	19.144	59.243	62.797						

厚度公差：+10%,-8% 水壓試驗壓力：50kg/cm²

■ END SCREWS

NOM SIZE	THREAD PER INCH
1/2" - 3/4"	14 T/in.
1" - 6"	11 T/in.

■ 電線用鋼管ANSI C80.1 RIGID STEEL CONDUIT

稱呼尺寸 Nom.Size	外徑 Outside Dia.		厚度 Wall thickness		單位重量 Unit Weight			每吋牙數 Threads per inch	螺紋長度 Length of Thread	
	in	in	mm	in	mm	lb/ft	kg/ft		kg/m	Effective mm
1/2	0.840	21.3	0.104	2.64	0.80	0.363	1.191	14	13.46	19.81
3/4	1.050	26.7	0.107	2.72	1.09	0.494	1.621	14	13.97	20.07
1	1.315	33.4	0.126	3.20	1.65	0.748	2.454	11-1/2	17.27	24.89
1-1/4	1.660	42.2	0.133	3.38	2.15	0.975	3.199	11-1/8	18.03	25.65
1-1/2	1.900	48.3	0.138	3.51	2.58	1.170	3.839	11-1/2	18.29	26.16
2	2.375	60.3	0.146	3.71	3.52	1.597	5.240	11-1/2	19.30	26.92
2-1/2	2.875	73.0	0.193	4.90	5.67	2.572	8.439	8	28.96	39.88
3	3.500	88.9	0.205	5.21	7.14	3.239	10.627	8	30.48	41.40
3-1/2	4.000	101.6	0.215	5.46	8.60	3.901	12.800	8	31.75	42.67
4	4.500	114.3	0.225	5.72	10.00	4.536	14.883	8	33.02	43.94
5	5.563	141.3	0.245	6.22	13.20	5.988	19.647	8	35.81	46.74
6	6.625	168.3	0.266	6.76	17.85	8.097	26.566	8	38.35	49.53

厚度公差：+不限，-12.5%

遠東®內刮黑鋼管 / 鍍鋅鋼管

專用於：1.瓦斯配管。 2.消防配管。 3.空調配管。 4.導線配管。

特點：1.管內無突出物，流動阻力小。 2.管內不易積污垢。 3.延長鋼管使用年限。 4.管內無焊渣。

■ 配管用碳鋼鋼管CNS 6445 G3127(JIS G3452 SGP) Carbon Steel Pipes for Ordinary Piping

直徑1"以上配管一律採用內焊屑刮除製程

Nominal Size		Outside Diameter		Wall Thickness		Weight (Plain End)		
(A)	(B)	mm	in	mm	in	lb/ft	kg/m	kg/ft
15	1/2	21.7	0.854	2.8	0.110	0.88	1.31	0.399
20	3/4	27.2	1.071	2.8	0.110	1.13	1.68	0.512
25	1	34.0	1.338	3.2	0.126	1.63	2.43	0.741
32	1 1/4	42.7	1.681	3.5	0.138	2.27	3.38	1.03
40	1 1/2	48.6	1.913	3.5	0.138	2.61	3.89	1.19
50	2	60.5	2.382	3.8	1.150	3.57	5.31	1.62
65	2 1/2	76.3	3.004	4.2	0.165	5.02	7.47	2.28
80	3	89.1	3.508	4.2	0.165	5.91	8.79	2.68
100	4	114.3	4.500	4.5	0.177	8.20	12.20	3.72
125	5	139.8	5.504	4.5	0.177	10.10	15.00	4.57
150	6	165.2	6.504	5.0	0.197	13.30	19.80	6.04
200	8	216.3	8.516	5.8	0.228	20.20	30.10	9.17
250	10	267.4	10.528	6.6	0.260	28.50	42.40	12.90
300	12	318.5	12.539	6.9	0.272	35.60	53.00	16.20
350	14	355.6	14.000	7.9	0.312	45.50	67.70	20.60
400	16	406.4	16.000	7.9	0.312	52.10	77.60	23.70
450	18	457.2	18.000	7.9	0.312	58.74	87.50	26.67
500	20	508	20.000	7.9	0.312	65.39	97.40	29.69

7 厚度公差：+不限，-12.5% 水壓試驗壓力：25kg/cm²

■ 電線用鋼管 CNS 2606 C4060 RIGID STEEL CONDUIT

DIMENSIONS AND WEIGHTS OF RIGID STEEL CONDUIT (厚鋼電線管之尺度、重量及有效螺紋長度)

管之稱呼 Nom Size	外徑 O.D.	外徑之容許差 O.D. Tolerance	近似厚度 Thickness	近似內徑 I.D.	長度 Length	重量 Weight	螺紋長度 Length of Thread	
							最長 Longest	最短 Shortest
mm	mm	mm	mm	mm	mm	kg/m	mm	mm
16	21.0	±0.3	2.3	16.4	4000/6000	1.06	19	16
22	26.5	±0.3	2.3	21.9	4000/6000	1.37	22	19
28	33.3	±0.3	2.5	28.3	4000/6000	1.90	25	22
36	41.9	±0.3	2.5	36.9	4000/6000	2.43	28	25
42	47.8	±0.3	2.5	42.8	4000/6000	2.79	28	25
54	59.6	±0.3	2.8	54.0	4000/6000	3.92	32	28
70	75.2	±0.3	2.8	69.6	4000/6000	5.00	36	32
82	87.9	±0.3	2.8	82.3	4000/6000	5.88	40	36
92	100.7	±0.4	3.5	93.7	4000/6000	8.39	42	36
104	113.4	±0.4	3.5	106.4	4000/6000	9.48	45	39

厚度公差：+不限，-7%

■ 壓力配管用碳鋼鋼管 CNS 4626 G3111 (JIS G3454 STPG) Carbon Steel Pipes for Pressure Service

直徑1"以上配管一律採用內焊屑刮除製程

稱呼尺寸 Nom Size		外徑 O.D.	標稱厚度號數 (Schedule No)							
			Sch 10		Sch 20		Sch 30		Sch 40	
A	B	mm	厚度 mm	重量 kg/m	厚度 mm	重量 kg/m	厚度 mm	重量 kg/m	厚度 mm	重量 kg/m
15	1/2	21.7	-	-	-	-	-	-	2.8	1.31
20	3/4	27.2	-	-	-	-	-	-	2.9	1.74
25	1	34.0	-	-	-	-	-	-	3.4	2.57
32	1 1/4	42.7	-	-	-	-	-	-	3.6	3.47
40	1 1/2	48.6	-	-	-	-	-	-	3.7	4.10
50	2	60.5	-	-	3.2	4.52	-	-	3.9	5.44
65	2 1/2	76.3	-	-	4.5	7.97	-	-	5.2	9.12
80	3	89.1	-	-	4.5	9.39	-	-	5.5	11.3
100	4	114.3	-	-	4.9	13.2	-	-	6.0	16.0
125	5	139.8	-	-	5.1	16.9	-	-	6.6	21.7
150	6	165.2	-	-	5.5	21.7	-	-	7.1	27.7
200	8	216.3	-	-	6.4	33.1	7.0	36.1	8.2	42.1
250	10	267.4	-	-	6.4	41.2	7.8	49.9	9.3	59.2
300	12	318.5	-	-	6.4	49.3	8.4	64.2	10.3	78.3
350	14	355.6	6.4	55.1	7.9	67.7	9.5	81.2	11.1	94.3
400	16	406.4	6.4	63.1	7.9	77.6	9.5	93.0	12.7	123

厚度公差：3mm以下±0.3mm

3mm(含)以上±10%

■ 水壓試驗壓力 單位：MPa { kgf/cm² }

標稱厚度號數 Sch No	10	20	30	40
水壓試驗壓力	2.0 {20}	3.5 {35}	5.0 {50}	6.0 {60}

■ 電線用鋼管 CNS 2606 C4060 (JIS C8305) RIGID STEEL CONDUIT (EMT)

DIMENSIONS AND WEIGHTS OF RIGID STEEL CONDUIT (無螺紋電線管之尺度、重量)

管之稱呼 Nom Size	外徑 O.D.	外徑之容許差 O.D. Tolerance	近似厚度 Thickness	近似內徑 I.D	長度 Length	長度之容許差	重量 Weight
mm	mm	mm	mm	mm	mm	mm	kg/m
E19	19.1	±0.15	1.2	16.7	3660	±5	0.530
E25	25.4	±0.15	1.2	23.0	3660	±5	0.716
E31	31.8	±0.15	1.4	29.0	3660	±5	1.50
E39	38.1	±0.15	1.4	35.3	3660	±5	1.27
E51	50.8	±0.15	1.4	48.0	3660	±5	1.71
E63	63.5	±0.25	1.6	60.3	3660	±5	2.44
E75	76.2	±0.25	1.8	72.6	3660	±5	3.30

重量許可差：+不限, -7%

- ASTM A671 低溫常壓用熔接鋼管。
- ASTM A672 中溫高壓用熔接鋼管。
- ASTM A691 高溫高壓用熔接鋼管。
生產範圍16"~80"厚度6mm以上，請電洽。

■ 正字標記證明書一覽表

品名	規格	證明書號碼	相對國外規格	用途
電導線用鍍鋅鋼管	CNS2606 C4060	台正字第 4656 號	JIS C8305,ANSI C80.1	電氣配管線及保護電線用
一般結構用碳鋼鋼管	CNS4435 G3102	台正字第 5032 號	JIS G3444	土木、建築、鐵塔、鷹架、樁支柱等
機械構造用碳鋼鋼管	CNS4437 G3103	台正字第 5033 號	JIS G3445	機械、飛機、汽車、自行車、家具、器具等
壓力配管用碳鋼鋼管	CNS4626 G3111	台正字第 5034 號	JIS G3454,API 5L,ASTMA-53	適用於350°C下之壓力配管
一般結構用矩形碳鋼鋼管	CNS7141 G3134	台正字第 4997 號	JIS G3466,ASTMA500	土木、建築及其他結構用
鋼管樁	CNS7934 A2114	台正字第 5126 號	JIS A5525,ASTMA252	土木工程與建築等構造物之基礎所使用之鋼管樁
配管用碳鋼鋼管	CNS6445 G3127	台正字第 6706 號	JIS G3452	消防、空調用配管